



## Axle Assemblies

**W**e stock a large selection of standard axle assemblies, replacement parts and running gear to fit small to large trailers. We also specialize in custom assemblies. Convenience, quality and economy are the reasons more people are turning to Redneck!

<b>Axles</b>		<b>Informational</b>	
2,000 lb	A-6	How to Select Axles and Running Gear	A-2
3,500 lb	A-8	How to Order Tubular Axle Assemblies	A-3
6,000 lb Regular Duty	A-10	How to Determine Correct Axle Position	A-3
6,000 lb Heavy Duty	A-12	The Protective Wiring Connector	A-4
7,000 lb	A-14	ABS by Dexter Axle	A-4
7,200 lb	A-16	Nev-R-Lube	A-5
8,000 lb	A-17	Lubricate the E-Z Way	A-5
9,000 lb	A-18	Rubber Torsion Axles	A-24
10,000 lb General Duty	A-19	How to Select Torflex Axles	A-25
10,000 lb Heavy Duty	A-20	How to Order Torflex Axles	A-25
12,000 lb Heavy Duty	A-21	How to Install Torflex Axles	A-26
15,000 lb Heavy Duty	A-22	How to Read Torflex	A-42
22,500 lb - 27,500 lb	A-23	Articulation Dimensions	
#8 Torflex	A-28		
#9 Torflex	A-30		
#10 Torflex	A-32		
#11 Torflex	A-34		
#12 & #12V Torflex	A-36		
#13 Torflex	A-38		
#10K Torflex	A-40		

The following information is to help you make a selection of axles and running gear from our wide range of possible choices; or call your branch and have one of our sales people assist you in choosing the right products.

## How to Select Axles and Running Gear:

- 1. How to Determine the Gross Vehicle Weight (GVW)**  
When building a trailer, the total Gross Vehicle Weight (GVW) must be determined in order to select the right axle or axles for the application. **GVW** includes the weight of the empty trailer and the weight of the intended cargo. (Example: 2,000 lb. empty trailer weight + 8,000 lbs. cargo = GVW of 10,000 lbs.)
- 2. How Many Axles?**  
After determining the GVW, the number and capacity of the axles must be selected. For example, if you want 10,000 lb. GVW and want tandem axles, the minimum required capacity is 6,000 lb. per axle.
- 3. Brakes?**  
First, determine if you want brakes on each axle. Most states require by law that at least one axle has brakes. Some states require that all axles have brakes. To determine how many brakes are necessary in a state, contact the local Department of Motor Vehicles. Second, determine what type of brake you prefer: Electric, Hydraulic Single-Serve, Hydraulic Free-Backing, Hydraulic Duo-Serve, Hydraulic Disc or Air "S" Cam Brakes?
- 4. Which Type of Spindles Are Going To Be Required?**  
**Straight spindles** are used mostly when the bed is over the tires or when low ground clearance is not required. Examples are flat beds, pull-type utility trailers, etc.  
**Drop spindles** are used when the lowest possible ground clearance is desired. Examples are Livestock and Horse Trailers, Car Haulers, Enclosed Cargo Van Trailers, etc.
- 5. What Are the Spring Centers?**  
Spring Centers are the CL (centerline) measurement of the Spring Mounting Pads on the axle. Spring centers are usually matched to the approximate frame width of the trailer.
- 6. Which Bolt Pattern?**  
The Bolt Pattern of the axles can vary depending on the capacity of the axle. The Bolt Pattern also determines what type tire and wheel can be used. If there is a specific tire and wheel you would like to use, please relay that information so we can help you to determine the proper bolt pattern and axle.
- 7. What is the Length of the Axle?**  
The next step is to determine the length of the axle. Of the several ways and industry terms to describe this procedure, the most popular term is "Hub Face," which is the measurement from the base of the wheel stud to the base of the wheel stud on the opposite end of the axle. Another term frequently used is "Track". Track is the center of the tire to the center of the opposite tire. This measurement varies depending on what type of wheel is used, because each type of wheel (White Spoke, O.E.M., Custom) could have a different offset, changing the tire center.
- 8. Which Type of Springs?**  
There are two basic types of springs to choose from: **Double Eye** or **Slipper Springs**. **Double Eye Springs** are used with the shackle-type suspensions. **Slipper Springs** are the heavy-duty springs used with slipper-type suspensions. Complete sets of springs and u-bolt kits can be ordered with axles.
- 9. Which Hanger Kit?**  
There are several Hanger Kits to choose from - single, tandem or triple for both double eye and slipper springs. Hanger Kits consist of Spring Hangers that attach to the frame, Equalizers (tandem or triple Hanger Kits), Shackle Straps (if double eye springs) and all the necessary hardware.

## How To Order Tubular Axle Assemblies

Our part numbers for Axles are assigned in accordance to the capacity, bolt pattern, type of brakes (if any) and type of spindle used. When ordering axles, the following information should be helpful to you.

**EX: 20545I-ST-EZ 2,000 lb., 5 on 4 1/2" Idler Straight with E-Z Lube**

**20 / 545 / I / ST / EZ**

- 20:** The first group of digits represent the capacity (20 = 2,000 lb. capacity)
- 545:** The next group represents the number of studs and the bolt pattern of the studs (545 = 5 on 4 1/2", 655 = 6 on 5 1/2", 865 = 8 on 6 1/2", etc.)
- I:** This tells you which type of brakes are used, if any.  
(I = Idler, E = Electric, H = Hydraulic, HFB = Hydraulic Free-Backing, A = Air)
- ST:** This tells you which type of spindles are used (ST = straight, 4D = 4" Drop)
- EZ:** Any other options (EZ = E-Z Lube Spindle, SPR = Springs Mounted)

## How to Determine Correct Axle Position

1. Weigh the trailer (under wheels) "Wheel Weight"
2. Obtain "Tongue Weight" (Actual)
3. Measure distance from tongue to axle, or to center between Dual Axle Set (D)
4. Determine Total Weight  
Total Weight = Tongue Weight + Wheel Weight

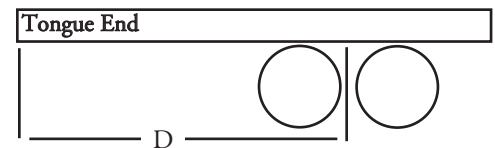

If tongue weight is greater than 10% of Total Weight, decrease distance "D" by "X" where

$$X = \frac{(\text{Tongue Weight} - 10\% \text{ Total})}{\text{Total Weight}} \text{ Times } D$$

### Example #1 - Tongue greater than 10% of Total Weight

Tongue Weight = 1025#  
 Wheel Weight = 7200#  
 D = 264"  
 Total Weight = 8225#  
 % Tongue Weight =  $\frac{1025}{8225} = 0.1246$  or 12 1/2%  
 "X" =  $\frac{1025 - 822.5}{8225} \text{ Times } 264 = 6.499"$

Move the Axle(s) toward the Tongue of the trailer approximately 6 1/2"  
 New D =  $264 - 6 \frac{1}{2} = 257.5"$

If tongue weight is less than 10% of Total Weight, increase distance "D" by "X" where

$$X = \frac{(10\% \text{ Total} - \text{Tongue Weight})}{\text{Total Weight}} \text{ Times } D$$

### Example #2 - Tongue less than 10% of Total Weight

Tongue Weight = 300#  
 Wheel Weight = 8200#  
 D = 264"  
 Total Weight = 8500#  
 % Tongue Weight =  $\frac{300}{8500} = 0.035$  or 3 1/2%  
 "X" =  $\frac{850 - 300}{8500} \text{ Times } 264 = 17"$

Move the Axle(s) toward the Rear of the trailer approximately 17"  
 New D =  $D + 17 = 264 + 17 = 281"$

## The Protective Wiring Connector!



AXLE  
ASSEMBLIES

The *primary cause of electric brake failure* is a loose or corroded connection in the brake wiring. The weakest point of the wiring connection is located under the trailer, at the axle, where the magnet wires exit the brake. Over time, the outer covering of the wires will become brittle and crack/break, exposing the wires, allowing the wires to short circuit against the trailer frame, axle, or against each other.

*What is a protective wiring connector?* It is an adjustable connector that attaches directly to the brake backing plate and allows you to attach most types of 1/2" I.D. conduit or loom to protect against rocks, dirt, snow, brush, etc.

This protective wiring connector may be ordered as a kit to retrofit existing axles (part # PWC1012), or may be pre-installed at the factory on new Dexter Axle assemblies for a minimal charge.

(Note: Axles ordered with the PWC option factory installed will not have the internal brake wiring inside the axle tube.)  
Protective Wiring Connector fits only Dexter Electric Brakes.

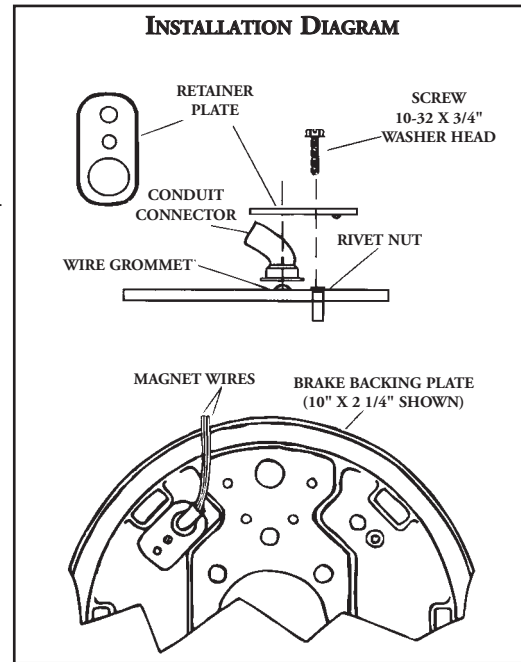

## ABS by DEXTER AXLE

**8,000 lb thru 25,000 lb Axles can be supplied ABS equipped, with sensors and exciter rings pre-installed.**

### Regulation

All trailer with air brakes, manufactured after March 1, 1998, must now have ABS in order to comply with FMVSS 571.121. This standard also applies to air-over-hydraulic brake systems.

### Required Equipment

An ABS system consists of wheel sensors that send electric impulses to an Electronic Control Unit (ECU) which pulses the service brakes in the event of wheel lockup. The minimum ABS configuration for a tandem axle trailer is a 2S/1M. This indicates two wheel sensors will be connected to and monitored by the ECU, and one modulator valve will control the service brakes. 4S/2M ABS configuration is also available from Redline.

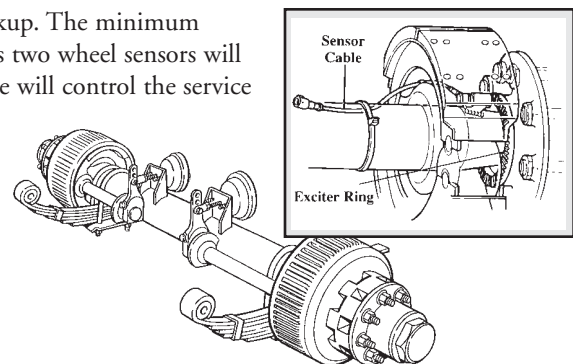

See pages A-17 thru A-23 and A-40 thru A-45 for axles, and L-13 thru L-14 for ABS control kits

## Nev-R-Lube

No need to pull the hubs to repack the bearings!  
No need to replace seals when you check the brakes!  
No more inner and outer bearings!

### Pre-set Adjustments.

Ease of installation. Human error is virtually eliminated in bearing adjustment.

### Pre-Lubricated at the Bearing Factory.

Resistant to contamination.

### Sealed for Life.

No bearing maintenance. Increased durability and reliability.

### Lower maintenance cost.

5-year or 100,000 miles warranty against defects in material or workmanship.



Available in 35mm cartridge, 42mm cartridge and 50mm cartridge.  
See pages A8 thru A17 and A32 thru A40 for specific application.

## Lubricate the E-Z Lube Way!



Keep bearings protected the easy way. Use the E-Z Lube Axle from Dexter.

The E-Z Lube design allows grease to flow with EASE to both outer and inner bearings for a complete repack. It's E-Z because all you need to do is attach a grease gun at the end and insert the grease. No disassembly required! E-Z Lube's end cap allows for easy access, extra protection and no mess.

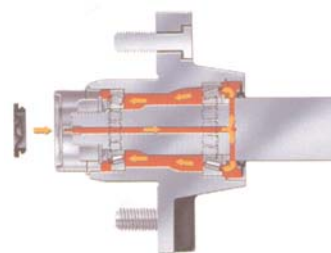

With such complete lubrication, your running gear is protected from corrosion and water entry. E-Z Lube protection and maintenance features make it ideal for almost any towable axle, whether it's for work or play.

Give your running gear the protection and maintenance with E-Z Lube from Dexter and Redneck!

**2,000 lb**



**SPECIFICATIONS**

**Suspension:**

Leaf Spring Suspension: (Choose from table on A-7)

- Double Eye versions
- Slipper Eye versions  
(Spring Kits to be sold separately.)

Hanger Kit Options: See Section D

**Bolt Pattern Options:**

- 4 on 4"
- 5 on 4 1/2" – 5 Bolt available with:  
5 1/2" Hub Flange – For 8" - 12" Wheels  
6 1/2" Hub Flange – For 12" - 15" Wheels

**Brake Options:** With or without parking feature.

- 7" x 1 1/4" Electric
- 7" x 1 3/4" Hydraulic Single Servo

**Spindles:** BTR Spindle, 1 1/16",

Uses L44649 Inner and Outer Bearings

- Straight
- 4" Drop

**Tubing:**

- 1 3/4" OD .180 wall (straight spindle only)
- 2 3/8" OD .156 wall (drop spindle only)

**Lubrication:**

- Grease
- E-Z Lube

**Wheel Assemblies:** See Section E

**Replacement Parts:**

- Idler Hub:** See Page B-12 and B-13
- Hub/Drums:** See Page B-18 and B-20
- Brakes:** See Page C-9 (Electric), Page C-25 (Hydraulic)
- Axle Beams:** See Page B-2

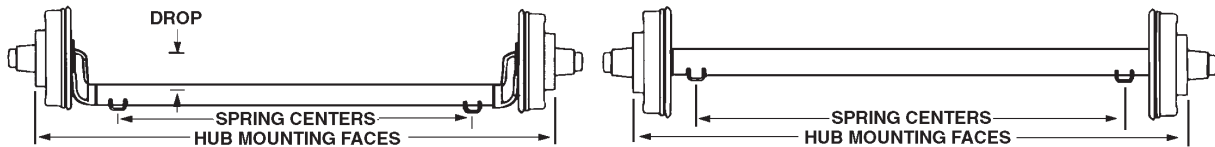

Difference Between Hub Face and Spring Center

Axle Type	Minimum	Recommended	Maximum
Straight	11.50"	14.75"	15.25"
Drop	15.25"	16.00"	18.00"

**NOTE:** Minimums are based on manufacturing tolerances only. Some tire and wheel combinations may create interference.

**2,000 lb. Axle Option**

Part No.	Ref No.	Description
XTRA-HF-2K	002450	EXTRA CHARGE (PER AXLE) FOR 2K AXLES OVER 96" HF

For information on selecting and ordering Tubular Axles, see pages A-2 thru A-3.  
For specific ordering information, please call your nearest Branch.

**2,000 lb. Axle Assemblies**

Axle Type	4 on 4"	5 on 4 1/2"
<b>Idler</b>		
Idler Straight	20440I-ST	20545I-ST
Idler Straight E-Z Lube	20440I-ST-EZ	20545I-ST-EZ
Idler 4" Drop	20440I-4D	20545I-4D
Idler E-Z Lube 4" Drop	20440I-4D-EZ	20545I-4D-EZ
<b>Electric</b>		
Electric Straight	20440E-ST	20545E-ST
Electric Straight E-Z Lube	20440E-ST-EZ	20545E-ST-EZ
Electric 4" Drop	20440E-4D	20545E-4D
Electric E-Z Lube 4" Drop	20440E-4D-EZ	20545E-4D-EZ
<b>Single Servo Hydraulic</b>		
Single Servo Hydraulic Straight	20440H-ST	20545H-ST
Single Servo Hydraulic Straight E-Z Lube	20440H-ST-EZ	20545H-ST-EZ
Single Servo Hyd 4" Drop	20440H-4D	20545H-4D
Single Servo Hyd E-Z Lube 4" Drop	20440H-4D-EZ	20545H-4D-EZ

**Spring and U-bolt Kits for 2,000 lb. Axles (Sold Separately)**

Part No.	Ref. No.	Per Spring Cap.	Length	Type	No. of Leaves
2-1020	003200	1,000 LB.	20 3/8"	Double Eye	3
2-1020-4D	003250	1,000 LB.	20 3/8"	Double Eye	3
2-PR-722	003460	1,250 LB.	25 1/4"	Double Eye	3
2-PR-722-4D	003470	1,250 LB.	25 1/4"	Double Eye	3
2-WIC2	003600	500 LB.	23 1/8"	Slipper	2
2-WIC2-4D	003650	500 LB.	23 1/8"	Slipper	2
2-WIE3	003800	750 LB.	23 1/8"	Slipper	3
2-WIE3-4D	003850	750 LB.	23 1/8"	Slipper	3
2-WIH4	004000	1,000 LB.	23 1/8"	Slipper	4
2-WIH4-4D	004050	1,000 LB.	23 1/8"	Slipper	4
2-WID2	004200	1,000 LB.	27 3/8"	Slipper	2
2-WID2-4D	004250	1,000 LB.	27 3/8"	Slipper	2
2-WIF3	004400	1,500 LB.	27 3/8"	Slipper	3
2-WIF3-4D	004450	1,500 LB.	27 3/8"	Slipper	3
2-WIG4	004600	1,750 LB.	27 3/8"	Slipper	4
2-WIG4-4D	004650	1,750 LB.	27 3/8"	Slipper	4

**3,500 lb**



**SPECIFICATIONS**

**Suspension:**

Leaf Spring Suspension: (Choose from table on A-9)

- Double Eye versions
- Slipper Eye versions  
(Spring Kits to be sold separately.)

Hanger Kit Options: See Section D

**Bolt Pattern Options:**

- 5 on 4 1/2", 4 3/4", 5", and 5 1/2"
- 6 on 5 1/2"

**Brake Options:** With or without parking feature.

- 10" x 2 1/4" Electric
- 10" x 2 1/4" Hydraulic (Single Servo or Freebacking)

**Spindles:** TTH (#84) Spindle

Uses L68149 Inner Bearing, L44649 Outer Bearing.

- Straight
- Drop: 4" or 6"

**Tubing:**

- 2 3/8" OD .180 wall (Standard)
- Optional – 3" OD .180 wall

**Lubrication:** • Grease • E-Z Lube Nev-R-Lube\*

**Wheel Assemblies:** See Section E

**Replacement Parts:**

- Idler Hub:** See Page B-14
- Hub/Drums:** See Page B-21, B-23 (Nev-R-Lube)
- Brakes:** See Page C-10 (Electric), Page C-26 (Hydraulic)
- Axle Beams:** See Page B-2

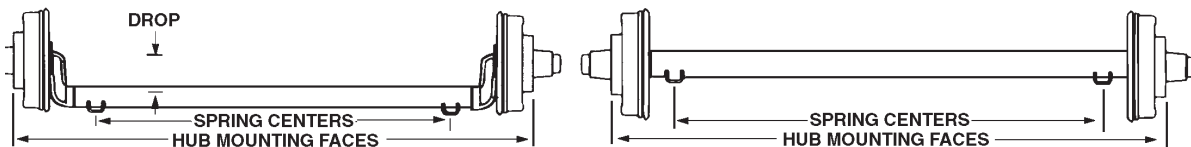

Difference Between Hub Face and Spring Center

Axle Type	Minimum	Recommended	Maximum
Straight	11.25"	16.00"	18.00"
4" Drop	14.00"	16.50"	18.00"
3" Tube Straight	11.25"	16.50"	23.00"
3" Tube 4" Drop	14.00"	16.50"	23.00"

**NOTE:** Minimums are based on manufacturing tolerances only. Some tire and wheel combinations may create interference.

**3500 LB. Axle Options**

Part No.	Ref No.	Description
10-PWC	013620	EXTRA CHARGE FOR 3500 LB ELECTRIC AXLES W/PWC OPTION INSTALLED
XTRA-HF-3.5K	013625	EXTRA CHARGE (PER AXLE) FOR 3500 LB AXLE OVER 96" HUBFACE

For information on selecting and ordering Tubular Axles, see pages A-2 thru A-3.

For specific ordering information, please call your nearest Branch.



**3500 lb. Axle Assemblies**

Axle Type	5 on 4 1/2"	5 on 4 3/4"	5 on 5"	5 on 5 1/2"	6 on 5 1/2"
<b>Idler</b>					
Straight	35545I-ST	355475I-ST	35550I-ST	35555I-ST	35655I-ST
Straight E-Z Lube	35545I-ST-EZ	355475I-ST-EZ	35550I-ST-EZ	35555I-ST-EZ	35655I-ST-EZ
4" Drop	35545I-4D	355475I-4D	35550I-4D	35555I-4D	35655I-4D
E-Z Lube 4" Drop	35545I-4D-EZ	355475E-4D-EZ	35550E-4D-EZ	35555E-4D-EZ	35655I-4D-EZ
<b>Electric</b>					
Straight	35545E-ST	355475E-ST	35550E-ST	35555E-ST	35655E-ST
Straight E-Z Lube	35545E-ST-EZ	355475E-ST-EZ	35550E-ST-EZ	35555E-ST-EZ	35655E-ST-EZ
Straight Nev-R-Lube	N/A	N/A	N/A	N/A	35655E-ST-NL
4" Drop	35545E-4D	355475E-4D	35550E-4D	35555E-4D	35655E-4D
4" Drop E-Z Lube	35545E-4D-EZ	355475E-4D-EZ	35550E-4D-EZ	35555E-4D-EZ	35655E-4D-EZ
<b>Single Servo Hydraulic</b>					
Straight	35545H-ST	355475H-ST	35550H-ST	35555H-ST	35655H-ST
Straight E-Z Lube	35545H-ST-EZ	355475H-ST-EZ	35550H-ST-EZ	35555H-ST-EZ	35655H-ST-EZ
Straight Nev-R-Lube	N/A	N/A	N/A	N/A	35655H-ST-NL
4" Drop	35545H-4D	355475H-4D	35550H-4D	35555H-4D	35655H-4D
4" Drop E-Z Lube	35545H-4D-EZ	355475H-4D-EZ	35550H-4D-EZ	35555H-4D-EZ	35655H-4D-EZ
<b>Hydraulic Freeback</b>					
Straight	35545HFB-ST	355475HFB-ST	35550HFB-ST	35555HFB-ST	35655HFB-ST
Straight E-Z Lube	35545HFB-ST-EZ	355475HFB-ST-EZ	35550HFB-ST-EZ	35555HFB-ST-EZ	35655HFB-ST-EZ
Straight Nev-R-Lube	N/A	N/A	N/A	N/A	35655HFB-ST-NL
4" Drop	35545HFB-4D	355475HFB-4D	35550HFB-4D	35555HFB-4D	35655HFB-4D
4" Drop E-Z Lube	35545HFB-4D-EZ	355475HFB-4D-EZ	35550HFB-4D-EZ	35555HFB-4D-EZ	35655HFB-4D-EZ

**Spring and U-bolt Kits available for 3,500 lb. Axles (Sold Separately)**

Part No.	Ref. No.	Per Spring Capacity	Length	Type	No. of Leaves
2-PR3	014600	1,750 lb.	25 1/4"	Double Eye	3
2-PR4B	014800	1,750 lb.	25 1/4"	Double Eye	4
2-PR4	015000	2,400 lb.	25 1/4"	Double Eye	4
2-803T3	015200	2,000 lb.	25 7/8"	Slipper	4

**6,000 lb**  
Regular Duty



**SPECIFICATIONS**

**Suspension:**

Leaf Spring Suspension: (Choose from table on A-11)

- Double Eye versions
- Slipper Eye versions  
(Spring Kits to be sold separately.)

Hanger Kit Options: See Section D

**Bolt Pattern Options:**

- 6 on 5 1/2"
- 8 on 6 1/2"
- UTG 5-Spoke

**Brake Options:** With or without parking feature.

- 12" x 2" Electric or Hydraulic, Single Servo, Freebacking, or Duo Servo.

**Spindles:** TTA (#42) Spindle, with 2 1/4" seal journal.

Uses 25580 Inner Bearing,

Uses LM67048, 15123, or 14125A Outer Bearing.

- Straight • 4" Drop

**Tubing:**

- 3" OD .180 wall

**Lubrication:**

- Grease • E-Z Lube • Oil Bath • Nev-R-Lube

**Wheel Assemblies:** See Section E

**Replacement Parts:**

**Idler Hub:** See Page B-15 and B-16

**Hub/Drums:** See Page B-22 – B-24, B-34(Nev-R-Lube)

**Brakes:** See Page C-11 (Electric),  
Page C-27 & C-28 (Hydraulic)

**Axle Beams:** See Page B-2

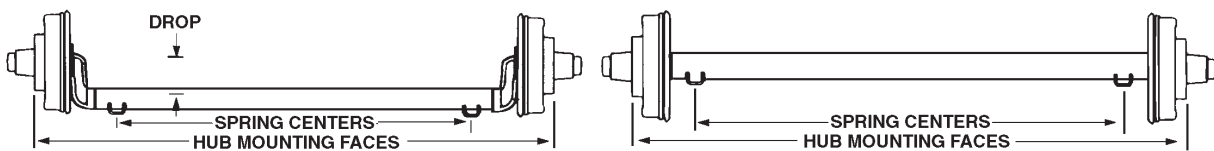

Difference Between Hub Face and Spring Center

Axle Type	Minimum	Recommended	Maximum
Straight	12.75"	15.00"	15.00"
Drop	15.75"	17.50"	17.50"

**NOTE:** Minimums are based on manufacturing tolerances only. Some tire and wheel combinations may create interference.

**6,000 lb. Axle Options**

Part No.	Ref. No.	Description
12-PWC	022735	EXTRA CHARGE FOR 6K ELECTRIC AXLES W/PWC OPTION INSTALLED
XTRA-HF-60R	018472	EXTRA CHARGE (PER AXLE) FOR 6K AXLES OVER 96" HUBFACE

For information on selecting and ordering Tubular Axles, see pages A-2 thru A-3.

For specific ordering information, please call your nearest Branch.

**6000 lb. Regular Duty Axles Assemblies**

Axle Type	6 of 5 1/2"	8 on 6 1/2"	UTG 5-SPOKE
<b>Idler</b>			
Straight	60R655I-ST	60R865I-ST	60RUTGI-ST
Straight E-Z Lube	60R655I-ST-EZ	60R865I-ST-EZ	60RUTGI-ST-EZ
Straight Oil Bath	N/A	60R865I-ST-OIL	60RUTOI-ST-OIL
4" Drop	60R655I-4D	60R865I-4D	60RUTGI-4D
4" Drop E-Z Lube	60R655I-4D-EZ	60R865I-4D-EZ	60RUTGI-4D-EZ
4" Drop Oil Bath	N/A	60R865I-4D-OIL	60RUTOI-4D-OIL
<b>Electric</b>			
Straight	60R655E-ST	60R865E-ST	60RUTGE-ST
Straight E-Z Lube	60R655E-ST-EZ	60R865E-ST-EZ	60RUTGE-ST-EZ
Straight Oil Bath	N/A	60R865E-ST-OIL	60RUTOE-ST-OIL
Straight Nev-R-Lube	60R655E-ST-NL	N/A	N/A
4" Drop	60R655E-4D	60R865E-4D	60RUTGE-4D
4" Drop E-Z Lube	60R655E-4D-EZ	60R865E-4D-EZ	60RUTGE-4D-EZ
4" Drop Oil	N/A	60R865E-4D-OIL	60RUTOE-4D-OIL
<b>Single Servo Hydraulic</b>			
Straight	60R655H-ST	60R865H-ST	60RUTGH-ST
Straight E-Z Lube	60R655H-ST-EZ	60R865H-ST-EZ	60RUTGH-ST-EZ
Straight Nev-R-Lube	60R655H-ST-NL	N/A	N/A
Straight Oil Bath	N/A	60R865H-ST-OIL	60RUTOH-ST-OIL
4" Drop	60R655H-4D	60R865H-4D	60RUTGH-4D
4" Drop E-Z Lube	60R655H-4D-EZ	60R865H-4D-EZ	60RUTGH-4D-EZ
4" Drop Oil	N/A	60R865H-4D-OIL	60RUTOH-4D-OIL
<b>Single Servo Hydraulic Freeback</b>			
Straight	60R655HFB-ST	60R865HFB-ST	60RUTGHFB-ST
Straight E-Z Lube	60R655HFB-ST-EZ	60R865HFB-ST-EZ	60RUTGHFB-ST-EZ
Straight Nev-R-Lube	60R655HFB-ST-NL	N/A	N/A
Straight Oil Bath	N/A	60R865HFB-ST-OIL	60RUTOHFB-ST-OIL
4" Drop	60R655HFB-4D	60R865HFB-4D	60RUTGHFB-4D
4" Drop E-Z Lube	60R655HFB-4D-EZ	60R865HFB-4D-EZ	60RUTGHFB-4D-EZ
4" Drop Oil Bath	N/A	60R865HFB-4D-OIL	60RUTOHFB-4D-OIL
<b>Duo Servo Hydraulic</b>			
Straight	60R655HY-ST	60R865HY-ST	60RUTGHY-ST
Straight E-Z Lube	60R655HY-ST-EZ	60R865HY-ST-EZ	60RUTGHY-ST-EZ
Straight Nev-R-Lube	60R655HY-ST-NL	N/A	N/A
Straight Oil Bath	N/A	60R865HY-ST-OIL	60RUTOHY-ST-OIL
4" Drop	60R655HY-4D	60R865HY-4D	60RUTGHY-4D
4" Drop E-Z Lube	60R655HY-4D-EZ	60R865HY-4D-EZ	60RUTGHY-4D-EZ
4" Drop Oil	N/A	60R865HY-4D-OIL	60RUTOHY-4D-OIL

**Spring and U-bolt Kits available for 6,000 lb. Axles (Sold separately)**

Part No.	Ref. No.	Per Spring Capacity	Length	Type	No. of Leaves
2-PR5	023000	2,900 lb.	25 1/4"	Double Eye	5
2-PR6	023100	3,300 lb.	25 1/4"	Double Eye	6
2-E5226	023200	3,000 lb.	25 1/4"	Slipper	5
2-1203T3	023300	3,500 lb.	24"	Slipper	5
2-1403T3	023400	4,000 lb.	24"	Slipper	7
2-E5115	023600	4,000 lb.	27 1/2"	Slipper	6

**6,000 lb**  
Heavy Duty



**SPECIFICATIONS**

**Suspension:**

Leaf Spring Suspension: (Choose from table on A-13)

- Double Eye versions
- Slipper Eye versions  
(Spring Kits to be sold separately.)

Hanger Kit Options: See Section D

**Bolt Pattern Options:**

- 6 on 5 1/2"
- 8 on 6 1/2"
- UTG 5-Spoke

**Brake Options:** With or without parking feature.

- 12" x 2" Electric or Hydraulic, Single Servo, Freebacking or Duo Servo.

**Spindles:** UTA (#42) Spindle, with 2 1/4" seal journal.

Uses 25580 Inner Bearing,

Uses LM67048, 15123, or 14125A Outer Bearing.

- Straight • 4" Drop

**Tubing:**

- 3" OD .250 wall optional 3.5" OD .50 wall for Air-Ride

**Lubrication:**

- Grease • E-Z Lube • Oil Bath • Nev-R-Lube

**Wheel Assemblies:** See Section E

**Replacement Parts:**

**Idler Hub:** See Page B-15 and B-16

**Hub/Drums:** See Page B-22 - B-24, B-34(Nev-R-Lube)

**Brakes:** See Page C-11 (Electric),  
Page C-27 & C-28 (Hydraulic)

**Axle Beams:** See Page B-2

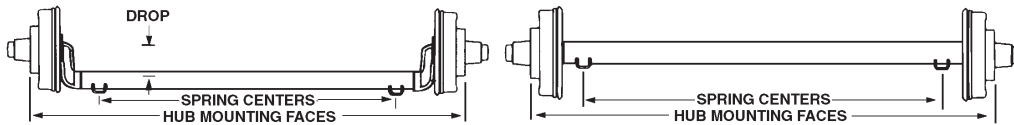

**Difference Between Hub Face and Spring Center**

Axle Type	Minimum	Recommended	Maximum
Straight	12.75"	16.25"	20.00"
Drop	15.75"	18.00"	20.00"

**NOTE:** Minimums are based on manufacturing tolerances only. Some tire and wheel combinations may create interference.

**6,000 lb. Axle Options**

Part No.	Ref. No.	Description
12-PWC	022735	EXTRA CHARGE FOR 6K ELECTRIC AXLES W/PWC OPTION INSTALLED
XTRA-HF-6K	020145	EXTRA CHARGE (PER AXLE) FOR 6K AXLES OVER 96" HUBFACE
ADD-6KHD-WALL	020150	ADD-ON FOR 6K AXLE, 3.5" OD .5" WALL TUBING FOR AIR-RIDE

For information on selecting and ordering Tubular Axles, see pages A-2 thru A-3.  
For specific ordering information, please call your nearest Branch.

**6,000 lb. Heavy Duty Axle Assemblies**

Axle Type	6 on 5 1/2"	8 on 6 1/2"	UTG 5 Spoke
<b>Idler</b>			
Straight	60655I-ST	60865I-ST	60UTGI-ST
Straight E-Z Lube	60655I-ST-EZ	60865I-ST-EZ	60UTGI-ST-EZ
Straight Oil Bath	N/A	60865I-ST-OIL	60UTOI-ST-OIL
4" Drop	60655I-4D	60865I-4D	60UTGI-4D
4" Drop E-Z Lube	60655I-4D-EZ	60865I-4D-EZ	60UTGI-4D-EZ
4" Drop Oil Bath	N/A	60865I-4D-OIL	60UTOI-4D-OIL
<b>Electric</b>			
Straight	60655E-ST	60865E-ST	60UTGE-ST
Straight E-Z Lube	60655E-ST-EZ	60865E-ST-EZ	60UTGE-ST-EZ
Straight Nev-R-Lube	60655E-ST-NL	60865E-ST-NL	N/A
Straight Oil Bath	N/A	60865E-ST-OIL	60UTOE-ST-OIL
4" Drop	60655E-4D	60865E-4D	60UTGE-4D
4" Drop E-Z Lube	60655E-4D-EZ	60865E-4D-EZ	60UTGE-4D-EZ
4" Drop Oil Bath	N/A	60865E-4D-OIL	60UTOE-4D-OIL
<b>Single Servo Hydraulic</b>			
Straight	60655H-ST	60865H-ST	60UTGH-ST
Straight E-Z Lube	60655H-ST-EZ	60865H-ST-EZ	60UTGH-ST-EZ
Straight Nev-R-Lube	60655H-ST-NL	60865H-ST-NL	N/A
Straight Oil Bath	N/A	60865H-ST-OIL	60UTOH-ST-OIL
4" Drop	60655H-4D	60865H-4D	60UTGH-4D
4" Drop E-Z Lube	60655H-4D-EZ	60865H-4D-EZ	60UTGH-4D-EZ
4" Drop Oil Bath	N/A	60865H-4D-OIL	60UTOH-4D-OIL
<b>Single Servo Hydraulic Freeback</b>			
Straight	60655HFB-ST	60865HFB-ST	60UTGHFB-ST
Straight E-Z Lube	60655HFB-ST-EZ	60865HFB-ST-EZ	60UTGHFB-ST-EZ
Straight Nev-R-Lube	60655HFB-ST-NL	60865HFB-ST-NL	N/A
Straight Oil Bath	N/A	60865HFB-ST-OIL	60UTOHFB-ST-OIL
4" Drop	60655HFB-4D	60865HFB-4D	60UTGHFB-4D
4" Drop E-Z Lube	60655HFB-4D-EZ	60865HFB-4D-EZ	60UTGHFB-4D-EZ
4" Drop Oil Bath	N/A	60865HFB-4D-OIL	60UTOHFB-4D-OIL
<b>Duo Servo Hydraulic</b>			
Straight	60655HY-ST	60865HY-ST	60UTGHY-ST
Straight E-Z Lube	60655HY-ST-EZ	60865HY-ST-EZ	60UTGHY-ST-EZ
Straight Nev-R-Lube	60655HY-ST-NL	60865HY-ST-NL	N/A
Straight Oil Bath	N/A	60865HY-ST-OIL	60UTOHY-ST-OIL
4" Drop	60655HY-4D	60865HY-4D	60UTGHY-4D
4" Drop E-Z Lube	60655HY-4D-EZ	60865HY-4D-EZ	60UTGHY-4D-EZ
4" Drop Oil Bath	N/A	60865HY-4D-OIL	60UTOHY-4D-OIL

**Spring and U-bolt Kits available for 6,000 lb. Axles (Sold separately)**

Part No.	Ref. No.	Per Spring Capacity	Length	Type	No. of Leaves
2-PR5	023000	2,900 lb.	25 1/4"	Double Eye	5
2-PR6	023100	3,300 lb.	25 1/4"	Double Eye	6
2-E5226	023200	3,000 lb.	25 1/4"	Slipper	5
2-1203T3	023300	3,500 lb.	24"	Slipper	5
2-1403T3	023400	4,000 lb.	24"	Slipper	7
2-E5115	023600	4,000 lb.	27 1/2"	Slipper	6

**7,000 lb**



**SPECIFICATIONS**

**Suspension:**

Leaf Spring Suspension: (Choose from table on next page)

- Double Eye versions
  - Slipper Eye versions
- (Spring Kits to be sold separately.)

Hanger Kit Options: See Section D

**Bolt Pattern Options:**

- 8 on 6 1/2"
- UTG 5-Spoke

**Brake Options:** With or without parking feature.

- 12" x 2" Electric or Hydraulic, Single Servo, Freebacking, or Duo Servo

**Spindles:** UTA (#42) Spindle, with 2 1/4" seal journal.

Uses 25580 Inner Bearing,

Uses 67048, 15123, or 14125A Outer Bearing.

- Straight • 4" Drop

**Tubing:**

- 3" OD .250 wall optional 3.5" OD .50 wall for Air-Ride

**Lubrication:**

- Grease • E-Z Lube • Oil Bath • Nev-R-Lube

**Wheel Assemblies:** See Section E

**Replacement Parts:**

**Idler Hub:** See Page B-16

**Hub/Drums:** See Page B-23 – B-24, B-34(Nev-R-Lube)

**Brakes:** See Page C-11 (Electric),

Page C-27 & C-28 (Hydraulic)

**Axle Beams:** See Page B-2

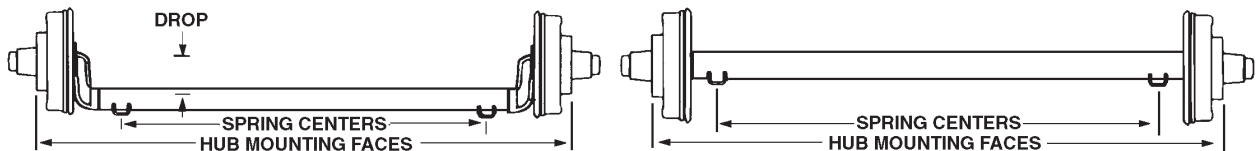

Difference Between Hub Face and Spring Center

Axle Type	Minimum	Recommended	Maximum
Straight	12.75"	16.25"	18.00"
Drop	15.75"	17.75"	18.00"

**NOTE:** Minimums are based on manufacturing tolerances only. Some tire and wheel combinations may create interference.

**7,000 lb. Axle Options**

Part No.	Ref. No.	Description
12-PWC	022735	EXTRA CHARGE FOR 6K ELECTRIC AXLES W/PWC OPTION INSTALLED
XTRA-HF-7K	022735	EXTRA CHARGE (PER AXLE) FOR 7K AXLES OVER 96" HUBFACE
ADD-7KHD-WALL	022736	ADD ON FOR 7K AXLE, 3.5" OD .5" WALL TUBING FOR AIR-RIDE

For information on selecting and ordering Tubular Axles, see pages A-2 thru A-3.

For specific ordering information, please call your nearest Branch.

**7,000 lb. Axle Assemblies**

Axle Type Idler	8 on 6 1/2"	UTG 5 Spoke
Straight	70865I-ST	70UTGI-ST
Straight E-Z Lube	70865I-ST-EZ	70UTGI-ST-EZ
Straight Oil Bath	70865I-ST-OIL	70UTOI-ST-OIL
4" Drop	70865I-4D	70UTGI-4D
4" Drop E-Z Lube	70865I-4D-EZ	70UTGI-4D-EZ
4" Drop Oil Bath	70865I-4D-OIL	70UTOI-4D-OIL
<b>Electric</b>		
Straight	70865E-ST	70UTGE-ST
Straight E-Z Lube	70865E-ST-EZ	70UTGE-ST-EZ
Straight Nev-R-Lube	70865E-ST-NL	N/A
Straight Oil Bath	70865E-ST-OIL	70UTOE-ST-OIL
4" Drop	70865E-4D	70UTGE-4D
4" Drop E-Z Lube	70865E-4D-EZ	70UTGE-4D-EZ
4" Drop Oil Bath	70865E-4D-OIL	70UTOE-4D-OIL
<b>Single Servo Hydraulic</b>		
Straight	70865H-ST	70UTGH-ST
Straight E-Z Lube	70865H-ST-EZ	70UTGH-ST-EZ
Straight Nev-R-Lube	70865H-ST-NL	N/A
Straight Oil Bath	70865H-ST-OIL	70UTOH-ST-OIL
4" Drop	70865H-4D	70UTGH-4D
4" Drop E-Z Lube	70865H-4D-EZ	70UTGH-4D-EZ
4" Drop Oil Bath	70865H-4D-OIL	70UTOH-4D-OIL
<b>Single Servo Hydraulic Freeback</b>		
Straight	70865HFB-ST	70UTGHFB-ST
Straight E-Z Lube	70865HFB-ST-EZ	70UTGHFB-ST-EZ
Straight Nev-R-Lube	70865HFB-ST-NL	N/A
Straight Oil Bath	70865HFB-ST-OIL	70UTOHFB-ST-OIL
4" Drop	70865HFB-4D	70UTGHFB-4D
4" Drop E-Z Lube	70865HFB-4D-EZ	70UTGHFB-4D-EZ
4" Drop Oil Bath	70865HFB-4D-OIL	70UTOHFB-4D-OIL
<b>Duo Servo Hydraulic</b>		
Straight	70865HY-ST	70UTGHY-ST
Straight E-Z Lube	70865HY-ST-EZ	70UTGHY-ST-EZ
Straight Nev-R-Lube	70865HY-ST-NL	N/A
Straight Oil Bath	70865HY-ST-OIL	70UTOHY-ST-OIL
4" Drop	70865HY-4D	70UTGHY-4D
4" Drop E-Z Lube	70865HY-4D-EZ	70UTGHY-4D-EZ
4" Drop Oil Bath	70865HY-4D-OIL	70UTOHY-4D-OIL

**DEXTER AXLE**
**Spring and U-bolt Kits available for 7,000 lb. Axles (Sold Separately)**

Part No.	Ref. No.	Per Spring Capacity	Length	Type	No. of Leaves
2-PR5	023000	2,900 lb.	25 1/4"	Double Eye	5
2-PR6	023100	3,300 lb.	25 1/4"	Double Eye	6
2-E5226	023200	3,000 lb.	25 1/4"	Slipper	5
2-1203T3	023300	3,500 lb.	24"	Slipper	5
2-1403T3	023400	4,000 lb.	24"	Slipper	7
2-E5115	023600	4,000 lb.	27 1/2"	Slipper	6

**7,200 lb**



**SPECIFICATIONS**

**Suspension:**

Leaf Spring Suspension: (Choose from table below)

- Double Eye versions
- Slipper Eye versions  
(Spring Kits to be sold separately.)

Hanger Kit Options: See Section D

**Bolt Pattern Options:**

- 8 on 6 1/2" (9/16" studs standard or optional 5/8")

**Brake Options:** • 12 1/4" x 2 1/2" Electric Only

**Spindles:** Uses 25580 Inner, 02475 Outer Bearings •Straight •4" Drop

**Tubing:** • 3" OD, .250 wall Optional 3.5" OD, .50 wall for Air-Ride

**Lubrication:** • Grease • E-Z Lube • Oil Bath

**Wheel Assemblies:** See Section E

7,200 lb. Axle Assemblies	
Axle Type	8 on 6 1/2"
Electric Straight	72865E-ST
Electric Straight E-Z Lube	72865E-ST-EZ
Electric Straight Oil Bath	72865E-ST-OIL
Electric 4" Drop	72865E-4D
Electric 4" Drop E-Z Lube	72865E-4D-EZ
Electric 4" Drop Oil Bath	72865E-4D-OIL

**Replacement Parts:**

- Hub/Drums:** See Page B-25
- Brakes:** See Page C-14 (Electric)
- Axle Beams:** See Page B-2

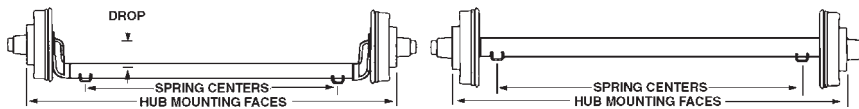

**Difference Between Hub Face and Spring Center**

Axle Type	Minimum	Recommended	Maximum
Straight	14.00"	15.00"	18.00"
Drop	15.75"	17.75"	18.00"

**NOTE:** Minimums are based on manufacturing tolerances only. Some tire and wheel combinations may create interference.

**Spring and U-bolt Kits available for 7,200 lb. Axles (Sold separately)**

Part No.	Ref. No.	Per Spring Capacity	Length	Type	No. of Leaves
2-PR5	023000	2,900 lb.	25 1/4"	Double Eye	5
2-PR6	023100	3,300 lb.	25 1/4"	Double Eye	6
2-E5226	023200	3,000 lb.	25 1/4"	Slipper	5
2-1203T3	023300	3,500 lb.	24"	Slipper	5
2-1403T3	023400	4,000 lb.	24"	Slipper	7
2-E5115	023600	4,000 lb.	27 1/2"	Slipper	6

**7,200lb. Axle Options**

Part No.	Ref. No.	Description
72K-PWC	022850	EXTRA CHARGE FOR 7.2K ELECTRIC AXLES W/PWC OPTION INSTALLED
XTRA-HF-7.2K	022875	EXTRA CHARGE (PER AXLE) FOR 7.2K AXLES OVER 96" HUBFACE
ADD-7.2KHD-WALL	022900	ADD ON FOR 7.2K AXLE, 3.5" OD .5" WALL TUBING FOR AIR-RIDE

For information on selecting and ordering Tubular Axles, see pages A-2 thru A-3.  
For specific ordering information, please call your nearest Branch.



**8,000 lb**



**SPECIFICATIONS**

**Suspension:**

Leaf Spring Suspension: (Choose from table below)

- Slipper Eye version (Only)  
(Spring Kits to be sold separately.)

Hanger Kit Options: See Section D

**Bolt Pattern Options:**

- 8 on 6 1/2" (9/16" studs standard or optional 5/8")

**Brake Options:** (Forward Self-Adjusting)

- 12 1/4" x 3 3/8" Electric
- 12 1/4" x 3 3/8" Hydraulic – Single or Duo-Servo, available with parking feature.
- ABS equipped option for hydraulic brakes

**Spindles:** Uses 25580 Inner, 02475 Outer Bearing •Straight • 4" Drop

**Tubing:** • 3.5" OD .250 wall Optional 3.5" OD, .50 wall for Air-Ride

**Lubrication:** • Grease • E-Z Lube • Oil Bath • Nev-R-Lube

**Wheel Assemblies:** See Section E

**8,000 lb. Axle Assemblies**

Axle Type	8 on 6 1/2"
<b>Idler</b>	
Straight Oil Bath	80865I-ST
Straight E-Z Lube	80865I-ST-EZ
4" Drop Oil Bath	80865I-4D
4" Drop E-Z Lube	80865I-4D-EZ
<b>Electric</b>	
Straight Oil Bath	80865E-ST
Straight E-Z Lube	80865E-ST-EZ
Straight Nev-R-Lube	80865E-ST-NL
4" Drop Oil Bath	80865E-4D
4" Drop E-Z Lube	80865E-4D-EZ
<b>Duo Servo Hydraulic</b>	
Straight Oil Bath	80865HY-ST
Straight E-Z Lube	80865HY-ST-EZ
Straight Nev-R-Lube	80865HY-ST-NL
4" Drop Oil Bath	80865HY-4D
4" Drop E-Z Lube	80865HY-4D-EZ

**Replacement Parts:**

- Idler Hub:** See Page B-17
- Hub/Drums:** See Page B-27, B-34(Nev-R-Lube)
- Brakes:** See Page C-15 (Electric), Page C-29 (Hydraulic)
- Axle Beams:** See Page B-2

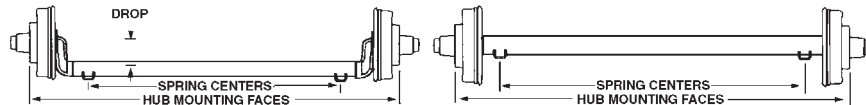

**Difference Between Hub Face and Spring Center**

Axle Type	Minimum	Recommended	Maximum
Straight	16.00"	19.00"	19.00"
Drop	18.00"	19.00"	19.00"

**NOTE:** Minimums are based on manufacturing tolerances only. Some tire and wheel combinations may create interference.

**Spring and U-bolt Kits available for 8,000 lb. Axles (Sold separately)**

Part No.	Ref. No.	Per Spring Capacity	Length	Type	No. of Leaves
2-E5226-8K	025200	3,000 lb.	25 1/4"	Slipper	5
2-1203T3-8K	025250	3,500 lb.	24 7/8"	Slipper	5
2-1403T3-8K	025600	4,000 lb.	24 7/8"	Slipper	7
2-E5115-8K	025400	4,000 lb.	27 1/2"	Slipper	6

**8,000lb. Axle Options**

Part No.	Ref. No.	Description
12.25-PWC	024975	EXTRA CHARGE FOR 12 1/4" ELECTRIC AXLES W/PWC OPTION INSTALLED
XTRA-HF-8K	024960	EXTRA CHARGE (PER AXLE) FOR 8K AXLES OVER 96" HUBFACE
8K-ADD-HYABS	024980	EXTRA CHARGE (PER AXLE) FOR HYD BRAKE AXLES W/ABS SENSORS & TONE RINGS INSTALLED
ADD-8KHD-WALL	024985	ADD ON FOR 8K AXLE, 3.5" OD .5" WALL TUBING FOR AIR-RIDE

For information on selecting and ordering Tubular Axles, see pages A-2 thru A-3.  
For specific ordering information, please call your nearest Branch.

**9,000 lb**



**SPECIFICATIONS**

**Suspension:**

Leaf Spring Suspension:

- Mounted 2" Wide Slipper Eye, Rubber Bushing
- Spring kits sold separately

Adjustable Spring Seat: For tracking alignment. (Optional)

Hanger Kit Options: See table below. (Sold Separately)

**Bolt Pattern Options:** • 8 on 6 1/2"

**Brake Options:** (Forward Self-Adjusting)

- 12 1/4" x 3 3/8" Electric
- 12 1/4" x 3 3/8" Hydraulic – Single or Duo-Servo, available with parking feature.
- ABS Equipped option for Hydraulic Brakes

**Spindles:** Uses 387A Inner, 25580 Outer Bearing

- Straight

**Tubing:**

- 4" OD .250 wall

**Lubrication:**

- Oil Bath

**Wheel Assemblies:** See Section E

**9,000 lb Axle Assemblies**

**8 on 6 1/2"**

Electric w/o Springs	9K865E-NOSPR
Duo Servo Hydraulic w/o Springs	9K865HY-NOSPR

**ABS Equipped 8 on 6 1/2"**

Electric w/o Springs	N/A
Duo Servo Hydraulic w/o Springs	9K865HABS-NOSPR

**Replacement Parts:**

**Hub/Drums:** See Page B-28 and B-29

**Brakes:** See Page C-15, C-16 (Electric),  
Page C-29, C-30 (Hydraulic)

**Axle Beams:** See Page B-2

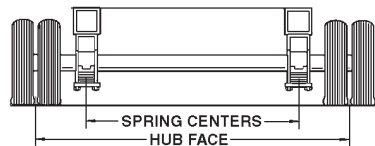

**Standard Axle Configurations**

	Dual Wheel	Dual Wheel	Dual Wheel	Single Wheel
Track Width	76.00"	72.00"	68.00"	85.00"
Spring Center - Max.	54.00"	50.00"	46.00"	63.00"
Spring Center - Min.	45.00"	41.00"	37.00"	54.00"

**NOTE:** Dimensions are based on manufacturing tolerances only. Some tire and wheel combinations may create interference.

**9,000 lb. Axle Options**

Part No.	Ref. No.	Description
9KHYD-PARK	030400	HYDRAULIC BRAKES W/ PARK, ADD TO 9K HYDRAULIC BRAKE AXLE
XTRA-HF-9K	030410	EXTRA CHARGE (PER AXLE) FOR 9K AXLES OVER 80" HUB FACE
9KADJ-SEAT	030415	ADJ SPG SEATS ALLOWS CORRECTION OF AXLE SPACING, PREVENTS SIDE TRACKING
72-10-2MT9K	030418	2 EA, 72-10-2 SPRINGS MTD ON ABOVE 9K AXLES

**Hanger and Attaching Parts Kits for 9,000 lb. (Sold Separately)**

Part No.	Ref. No.	Description
HAP-105-00	030420	9K SINGLE AXLE HANGER AND ATTACHING PARTS KIT
HAP-205-01	030440	9K MULTI-AXLE CONVERSION KIT FOR 38" AXLE SPACING
HAP205-02	030460	9K MULTI-AXLE CONVERSION KIT FOR 42 1/4" AXLE SPACING
HAP205-03	030480	9K MULTI-AXLE CONVERSION KIT FOR 48 1/2" AXLE SPACING

For information on selecting and ordering Tubular Axles, see pages A-2 thru A-3.  
For specific ordering information, please call your nearest Branch.

**10,000 lb**  
General Duty



**SPECIFICATIONS**

**Suspension:**

Leaf Spring Suspension:

- Mounted 2 1/2" Wide Slipper Eye, Bronze Bushing
- Spring kit sold separately

Adjustable Spring Seat: For tracking alignment. (Optional)

Hanger Kit Options: See table below. (Sold Separately)

**Bolt Pattern Options:** • 8 on 6 1/2"

**Brake Options:** (Forward Self-Adjusting)

- 12 1/4" x 3 3/8" Electric
- 12 1/4" x 3 3/8" Hydraulic – Single or Duo-Servo, available with parking feature.
- ABS Equipped option for Hydraulic Brakes.

**Spindles:** Uses 387A Inner, 25580 Outer Bearing

- Straight

**Tubing:**

- 5" OD .250 wall

**Lubrication:**

- Oil Bath

**Wheel Assemblies:** See Section E

**10,000 lb GD Axle Assemblies**

**8 on 6 1/2"**

Electric w/o Springs	10GD865E-NOSPR
Duo Servo Hydraulic w/o Springs	10GD865HY-NOSPR

**ABS Equipped 8 on 6 1/2"**

Electric w/o Springs	N/A
Duo Servo Hydraulic w/o Springs	10GD865HABSNSPR

**Replacement Parts:**

- Hub/Drums:** See Page B-29
- Brakes:** See Page C-16 (Electric),  
Page C-30 (Hydraulic)
- Axle Beams:** See Page B-2

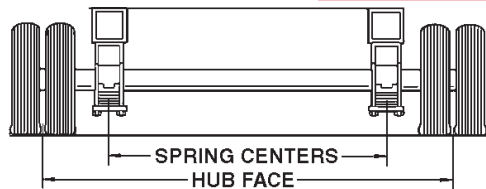

**Standard Axle Configurations**

	Dual Wheel	Dual Wheel	Single Wheel
Track Width	74.00"	66.00"	84.00"
Spring Center - Max.	48.00"	40.00"	58.00"
Spring Center - Min.	43.00"	35.00"	53.00"

**NOTE:** Dimensions are based on manufacturing tolerances only. Some tire and wheel combinations may create interference.

**10,000 lb. General Duty Axle Options**

Part No.	Ref. No.	Description
10GDHYD-PARK	032410	HYDRAULIC BRAKES W/ PARK, ADD TO 10K GD HYDRAULIC BRAKE AXLE
XTRA-HF-10KGD	032425	EXTRA CHARGE (PER AXLE) FOR 10K GD AXLES OVER 80" HUB FACE
10GDADJ-SEAT	032430	ADJ SPG SEATS ALLOWS CORRECTION OF AXLE SPACING, PREVENTS SIDE TRACKING
72-21MT10GD	032600	2 EA, 72-21 SPRINGS MTD ON ABOVE 10K GD AXLES

**Hanger and Attaching Parts Kits for 9,000 lb. (Sold Separately)**

Part No.	Ref. No.	Description
HAP-156-00	032700	10K GD SINGLE AXLE HANGER AND ATTACHING PARTS KIT
HAP-256-01	033100	10K GD MULTI-AXLE CONVERSION KIT FOR 38" AXLE SPACING
HAP256-02	033300	10K GD MULTI-AXLE CONVERSION KIT FOR 42 1/4" AXLE SPACING
HAP256-03	033500	10K GD MULTI-AXLE CONVERSION KIT FOR 48 1/2" AXLE SPACING

For information on selecting and ordering Tubular Axles, see pages A-2 thru A-3.

For specific ordering information, please call your nearest Branch.

**10,000 lb**  
Heavy Duty



AXLE  
ASSEMBLIES

**SPECIFICATIONS**

**Suspension:**

Leaf Spring Suspension:

- Mounted 3" Wide Slipper Eye, Rubber Bushing
- Spring kits sold separately

Adjustable Spring Seat: For tracking alignment (Optional)

Hanger Kit Options: (Sold Separately)

**Brake Options:**

- 12 1/4" x 4" Electric – Forward Self-Adjusting
- 12 1/4" x 4" Hydraulic – Forward Self-Adjusting, Single or Duo-Servo, available with parking feature
- Hydraulic Disc
- Air Brakes-  
Manual Slack Adjusters – Standard  
Automatic Slack Adjusters – Optional
- ABS Equipped option for Hyd, Disc, & Air Brakes

**Bolt Pattern Options:** • 8 on 6 1/2"

**Spindles:** Uses 395S Inner, 387A Outer Bearing

- Straight

**Tubing:**

- 5" OD .250 wall • Optional .440" wall for use w/Air-Ride Suspension

**Lubrication:**

- Oil Bath

**Wheel Assemblies:** See Section E

10,000 lb. Heavy Duty Axle Assemblies	
<b>8 on 6 1/2"</b>	
Electric w/o Springs	10K865E-NOSPR
Hydraulic w/o Springs	10K865HY-NOSPR
Hydraulic Disc w/o Springs	10K865DS-NOSPR
Air Brake w/o Springs	10K865A-NOSPR
Air Brake w/o Park, no Springs	10K865ASB-NOSPR
<b>ABS Equipped 8 on 6 1/2"</b>	
Electric w/o Springs	N/A
Hydraulic w/o Springs	10K865HABSNSPR
Hydraulic Disc w/o Springs	10K865DABSNSPR
Air Brake w/o Springs	10K8A-ABSNSPR
Air Brake w/o Park, no Springs	10K8APABSNSPR

**Replacement Parts:**

**Hub/Rotor:** See Page B-30

**Hub/Drums:** See Page B-29

**Brakes:** See Page C-18 (Electric), Page C-31 (Hydraulic)  
See Page C-33 (Disc), Page C-34 (Air)

**Axle Beams:** See Page B-2

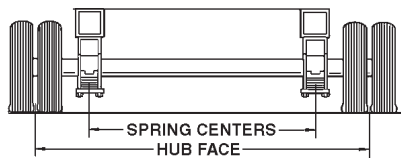

**NOTE:** Dimensions are based on manufacturing tolerances only. Some tire and wheel combinations may create interference.

**Standard Axle Configurations:**

	Dual Wheel	Dual Wheel	Single Wheel
Track Width	74.00"	66.00"	84.00"
Spring Center - Max.	48.00"	40.00"	58.00"
Spring Center - Min.	43.00"	35.00"	53.00"

**10K Heavy Duty Axle Options**

Part No.	Ref. No.	Type
ADD-10KHD-WALL	035250	ADD PER AXLE FOR .44 HVY WALL TUBING (REQUIRED FOR AIR RIDE SUSPENSION)
10KHYD-PARK	03540	HYDRAULIC BRAKES W/PARK ADD TO 10K HEAVY-DUTY AXLES
XTRA-HF-10K	035425	EXTRA CHARGE PER AXLE FOR 10K HEAVY-DUTY AXLES WITH OVER 80" HUB FACE
10KADJ-SEAT	035450	ADJ SPG SEATS ALLOWS CORRECTION OF AXLE SPACING, PREVENTS SIDE TRACKING
ADD-AUTOSL	043125	ADD PER AXLE FOR AUTOMATIC SLACK ADJUSTERS (AIR BRAKE)
72-43-1MT10K	040700	2 EA, 72-43-1 SPRINGS MTD ON ABOVE 10K AXLES

See Pages D-11 for Available Hanger and Attaching Parts Kits for 10,000 lb. Heavy Duty axles.

For information on selecting and ordering Tubular Axles, see pages A-2 thru A-3.

For specific ordering information, please call your nearest Branch.

**12,000 lb**  
Heavy Duty



**SPECIFICATIONS**

**Suspension:**

Leaf Spring Suspension:

- Mounted 3" Wide Slipper Eye, Rubber Bushing
- Spring kits sold separately

Adjustable Spring Seat: For tracking alignment. (Optional)

Hanger Kit options – (sold separately)

**Brake Options:**

- 12 1/4" x 5" Electric – Forward Self-Adjusting
- 12 1/4" x 5" Hydraulic – Forward Self-Adjusting, Single or Duo-Servo, available with parking feature
- Hydraulic Disc
- Air Brakes-  
Manual Slack Adjusters – Standard  
Automatic Slack Adjusters – Optional
- ABS Equipped option for Hyd, Disc, & Air Brake

**Bolt Pattern Options:** • 8 on 6 1/2"

Standard: Hi Profile Hub for 16", 16.5" dia. wheels;  
Optional: Low Profile for 14.5" wheels.

**Spindles:** Uses 3984 Inner, 28682 Outer Bearing

- Straight

**Tubing:** • 5" OD .440 wall

**Lubrication:**

- Oil Bath

**Wheel Assemblies:** See Section E

**12,000 lb Heavy Duty Axle Assemblies**

8 on 6 1/2"	Hi-Profile	Lo-Profile
Electric w/o springs	12K865E-NOSPR	12K865LPE-NOSPR
Hydraulic Disc w/o Springs	12K865DS-NOSPR	N/A
Duo-Servo Hydraulic w/o Springs	12K865HY-NOSPR	12K865LPHYNSPR
Air Brake w/o Springs	12K865A-NOSPR	12K865LPANSPR
Air Brake w/o Park & Springs	12K865ASB-NOSPR	12K865LPASB-NOSPR
<b>ABS Equipped 8 on 6 1/2"</b>		
Electric w/o springs	N/A	N/A
Hydraulic Disc w/o Springs	12K865DABSNSPR	N/A
Duo-Servo Hydraulic w/o Springs	12K865HABSNSPR	12K8LPHABSNSPR
Air Brake w/o Springs	12K865A-ABSNSPR	12K8ALPABSNSPR
Air Brake w/o Park & Springs	12K865APABSNSPR	12K8LPAPABSNSPR

**Replacement Parts:**

**Hub/Rotor:** See Page B-31

**Hub/Drums:** See Page B-31

**Brakes:** See Page C-19 (Electric), Page C-32 (Hydraulic), Page C-33 (Disc), Page C-34 (Air)

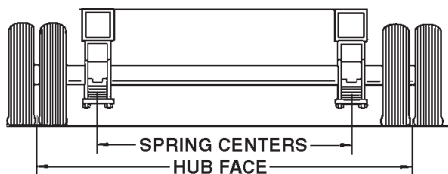

**NOTE:** Dimensions are based on manufacturing tolerances only. Some tire and wheel combinations may create interference.

**Standard Dual Wheel Axle Configurations**

	Low Profile		High Profile	
Track Width	74.50"	70.50"	74.00"	66.00"
Spring Center - Max.	41.00"	37.00"	47.50"	39.50"
Spring Center - Min.	33.50"	29.50"	33.00"	25.00"

**12K Heavy Duty Axle Options**

Part No.	Ref. No.	Type
12KHYD-PARK	037200	HYDRAULIC BRAKES W/ PARK ADD TO 12K HEAVY-DUTY AXLES
XTRA-HF-12K	037225	EXTRA CHARGE (PER AXLE) FOR 12K HEAVY-DUTY AXLES OVER 80" HUB FACE
12KADJ-SEAT	037250	ADJ SEATS ALLOWS CORRECTION OF AXLE SPACING, PREVENTS SIDE TRACKING
ADD-AUTOSL	043125	ADD PER AXLE FOR AUTOMATIC SLACK ADJUSTERS (AIR BRAKES)
72-44-1MT12K	040740	2 EA, 72-44-1 SPRINGS MTD ON ABOVE 12K AXLES

See Pages D-11 for Available Hanger and Attaching Parts Kits for 12,000 lb. Heavy Duty axles.

For information on selecting and ordering Tubular Axles, see pages A-2 thru A-3.

For specific ordering information, please call your nearest Branch.

**15,000 lb**  
Heavy Duty

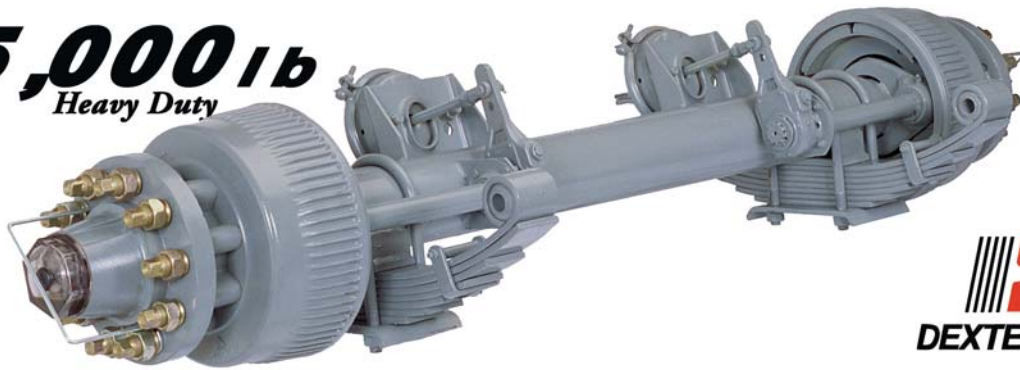

**SPECIFICATIONS**

**Suspension:**

Leaf Spring Suspension:

- Mounted 3" wide Slipper Eye, Rubber Bushing
- Spring kit sold separately

Adjustable Spring Seat: For tracking alignment. (Optional)

Hanger Kit options – (sold separately)

**Brake Options:**

- 12 1/4" x 5" Electric – Forward Self-Adjusting
- 12 1/4" x 5" Hydraulic – Forward Self-Adjusting, Single or Duo-Servo, available with parking feature
- Air Brakes-  
Manual Slack Adjusters – Standard  
Automatic Slack Adjusters – Optional
- ABS equipped option for Hyd and Air Brakes

**Bolt Pattern Options:** • 10 on 8 3/4"

**Spindles:** Uses 3984 Inner, 28682 Outer Bearing

- Straight

**Tubing:**

- 5" OD .440 wall

**Lubrication:**

- Oil Bath

**Wheel Assemblies:** See Section E

**15,000 lb. Heavy Duty Axle Assemblies**

**10 on 8 3/4"**

Electric w/o Springs	15K10E-NOSPR
Duo-Servo Hydraulic w/o Springs	15K10HY-NOSPR
Air Brake w/o Springs	15K10A-NOSPR
Air Brake w/o Spring Brakes Springs	15K10ASB-NOSPR
<b>ABS Equipped 10 on 8 3/4"</b>	
Electric w/o Springs	N/A
Duo-Servo Hydraulic w/o Springs	15K10HABS-NOSPR
Air Brake w/o Springs	15K10AABS-NOSPR
Air Brake w/o Spring Brakes Springs	15K10APABSNSPR

**Replacement Parts:**

**Hub/Drums:** See Page B-32

**Brakes:** See Page C-19 (Electric),  
Page C-32 (Hydraulic), Page C-40 (Air)

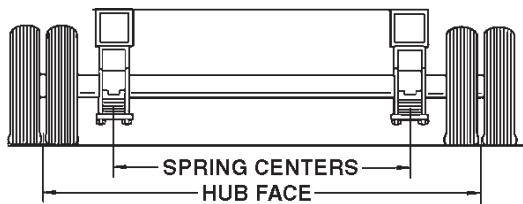

**NOTE:** Dimensions are based on manufacturing tolerances only. Some tire and wheel combinations may create interference.

**Standard Axle Configurations**

	Dual Wheel	Dual Wheel
Track Width	75.00"	67.00"
Overall Width	96.00"	88.00"
Spring Center - Max.	46.00"	38.00"
Spring Center - Min.	42.00"	34.00"

**15K Heavy Duty Axle Options**

Part No.	Ref No.	Type
15KHYD-PARK	040600	HYD BRAKES W/ PARK, ADD TO 15K HYD BRAKE AXLE PRICE
XTRA-HF-15K	040610	EXTRA CHARGE (PER AXLE) FOR 15K AXLES OVER 80" HUB FACE
15KADJ-SEAT	040615	ADJ SPG SEATS ALLOWS CORRECTION OF AXLE SPACING, PREVENTS SIDE TRACKING
ADD-AUTOSL	043125	ADD PER AXLE FOR AUTOMATIC SLACK ADJUSTERS (AIR BRAKE)
72-45-1MT15K	040770	2 EA, 72-45-1 SPRINGS MTD ON ABOVE 15K AXLES

See Pages D-11 for Available Hanger and Attaching Parts Kits for 15,000 lb. Heavy Duty axles.

For information on selecting and ordering Tubular Axles, see pages A-2 thru A-3.

For specific ordering information, please call your nearest Branch.

# 22,500 lb - 27,500 lb Heavy Duty



ASSEMBLIES

## SPECIFICATIONS

**Suspensions:** See pages D-27 and D-28 for listing.

**Bolt Pattern Options:** • 3 Spoke Cast • 5 Spoke Cast  
• 10 on 8 3/4" • 10 on 11 1/4"

**Brake Options:** • 12 1/4" x 7 1/2" "S" Cam Air Brakes  
• 16 1/2" x 7" "S" Cam Air Brakes  
• Spring Brakes\* &/or ABS Equipped\* Axles available upon request

**Cam Shaft:** Various lengths are available upon request.\*

**Slack Adjusters:** Slack adjusters are available in Manual, Automatic\* and/or Curved\* models.

**Spindles:** HM218248 Inner, HM212049 Outer Bearing

**Air Chambers:** Type 30 Service Chamber Standard

**Spring Brakes:** Available upon request

**Seals:** Unitized National or Stemco\* Seals

\* Indicates those parts which are optional features and an additional charge from the standard models.

**Track:** Standard Tracks are 71 1/2" and 68", 77 1/2"\*  
(\*special tracks available upon request)

Note: Axle tracks under 71" may be subject to clearance problems when used w/ air-ride suspensions

**Tubing/Beam Capacity:** 5" OD .50" wall (22,500lb),  
.62" (25,000 lb), .75" (27,500 lb),

Capacities reduced in off-road and/or Air-Ride suspension applications. A minimum of .62" wall thickness required for Air-Ride Suspensions

**Spring Centers:**

Maximum: Track minus 32 1/2" or as tire clearance allows.

Minimum: Track minus 34 1/2"

### Replacement Parts:

**Brakes:** See Page C-40 (Air)

## Heavy Duty Axle Assemblies

Axle Type	.50" Nominal Wall Thickness	.62" Nominal Wall Thickness	.75" Nominal Wall Thickness
<b>12 1/4" x 7 1/2" Brake</b>			
Less Hub and Drum	D200-5-LHD12	D200-6-LHD12	D200-7-LHD12
3 Spoke Cast Hub & Drum for 15" & 17.5" Rims	D200-5-3SPK12	D200-6-3SPK12	D200-7-3SPK12
3 Spoke Cast Hub & Drum for 15" & 17.5" Rims, w/ ABS Sensors & Tone Rings	D200-5-3SP12ABS	D200-6-3SP12ABS	D200-7-3SP12ABS
10 on 8 3/4" Bolt Circle Hub and Drum	D200-5-10-12	D200-6-10-12	D200-7-10-12
10 on 8 3/4" Bolt Circle Hub and Drum, w/ ABS Sensor & Tone Rings	D200-5-10-12ABS	D200-6-10-12ABS	D200-7-10-12ABS
<b>16 1/2" x 7" Brake</b>			
Less Hub and Drum	D200-5-LHD16	D200-6-LHD16	D200-7-LHD16
5 Spoke Cast Hub and Drum, for 20" & 22.5" Rims	D200-5-5SPK16	D200-6-5SPK16	D200-7-5SPK16
5 Spoke Cast Hub and Drum, for 20" & 22.5" Rim, w/ ABS Sensor and Tone Rings	D200-5-5SP16ABS	D200-6-5SP16ABS	D200-7-5SP16ABS
10 on 11 1/4" Bolt Circle Hub & Drum	D200-5-10-16	D200-6-10-16	D200-7-10-16
10 on 11 1/4" Bolt Circle Hub and Outboard Drum	D200-5-10-16OB	D200-6-10-16OB	D200-7-10-16OB
10 on 11 1/4" Bolt Circle Hub and Outboard Drum, w/ ABS Sensor and Tone Rings	D200-5-10-16ABS	D200-6-10-16ABS	D200-7-10-16ABS

## Axle Options

Part No.	Ref. No.	Type
XTRA-HF-20K	042070	EXTRA CHARGE (PER AXLE) FOR AXLES W/TRACK 71.6" THRU 77.5"
XTRAWD-HF-20K	042072	EXTRA CHARGE (PER AXLE) FOR AXLES W/TRACK 77.6" THRU 92.5"
SUPRWD-HF-20K	042100	EXTRA CHARGE (PER AXLE) FOR AXLES W/TRACK 92.6" & OVER
ADD-STEMCO	043075	ADD PER AXLE FOR STEMCO GRIT GUARD SEALS
ADD-3030SB	043100	ADD PER AXLE FOR TYPE 30-30 SPRING BRAKE CHAMBERS
ADD-AUTOSL	043125	ADD PER AXLE FOR AUTOMATIC SLACK ADJUSTERS (AIR BRAKE)
D200-16-ADD-HPS	042066	HUB PILOTED OPTION, (STEEL WHEEL) ADD-ON TO 10-11.25 OUTBOARD DRUM

For information on selecting and ordering Tubular Axles, see pages A-2 thru A-3.  
For specific ordering information, please call your nearest Branch.

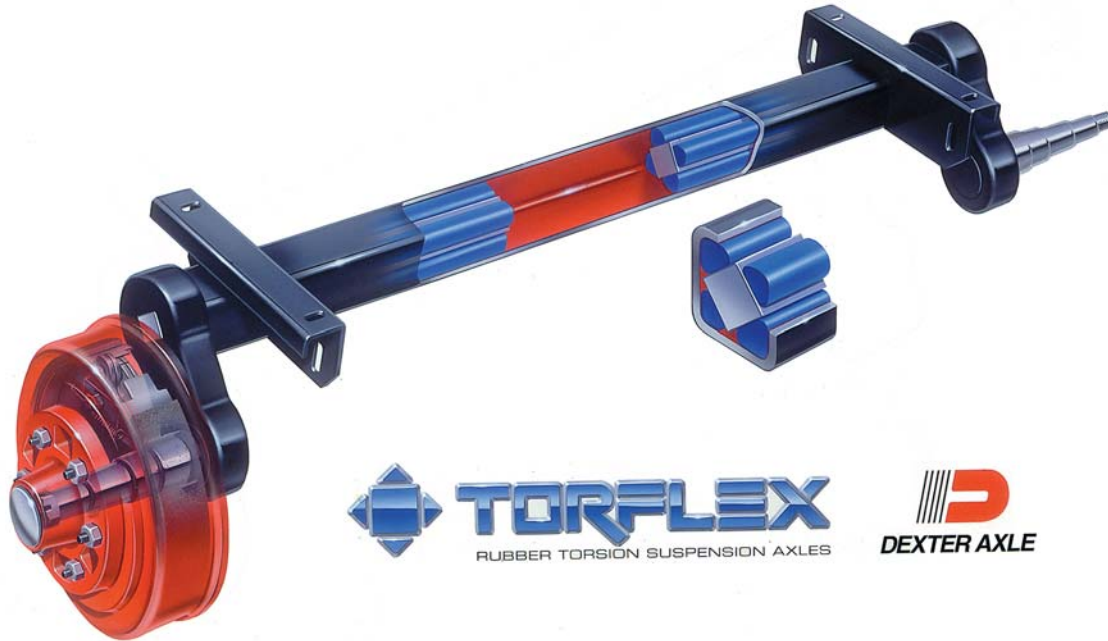

## Rubber Torsion Axles

# 5 YEAR WARRANTY

### FEATURES:

- Totally cushioned in rubber for a smooth quiet ride
- Independent wheel suspension
- Maximum stability
- Load carrying cross member
- Low profile with maximum road clearance
- Quick and easy to install (4 bolts required)
- 5 year warranty on the suspension systems

### OPTIONS:

- 600 lb. thru 10,000 lb. capacities
- Available with no brakes, electric brakes or hydraulic brakes
- Industry standard hubs and hub-drums
- Custom built to your specifications
- E-Z Lube



## How to Select Torflex Axles:



1. **How to Determine the Gross Vehicle Weight (GVW)**  
When building a trailer, the total Gross Vehicle Weight (GVW) must be determined in order to select the right axle or axles for the application. GVW includes the weight of the empty trailer and the weight of the intended cargo. (Example: 2,000 lb. empty trailer weight + 8,000 lbs. cargo = GVW of 10,000 lbs.)
2. **How Many Axles?**  
After determining the GVW, the number and capacity of the axles must be selected. For example, if you want 10,000 lb. GVW and want tandem axles, the minimum required capacity is 6,000 lb. per axle.
3. **Brakes?**  
First, determine if you want brakes on each axle. Most states require by law that at least one axle has brakes. Many states require that all axles have brakes. To determine how many brakes are necessary in a state, contact the local Department of Motor Vehicles. Second, determine what type of brake you prefer. Choose from Electric, Hydraulic Single-Serve or Hydraulic Duo-Serve.
4. **What is the Length of the Axle?**  
Of the several ways and industry terms to describe this procedure, the most popular term is "Hub Face" which is the measurement from the base of the wheel stud to the base of the wheel stud on the opposite end of the axle.
5. **Which Bolt Pattern?**  
The Bolt Pattern of the axles can vary depending on the capacity of the axle. The Bolt Pattern also determines what type tire and wheel can be used. If there is a specific tire and wheel you would like to use, please relay that information so we can help you to determine the proper bolt pattern and axle.
6. **What is the Outside Frame Dimension?**  
Since the mounting brackets of the Torflex axles mount directly to the frame of your trailer, it is necessary to know the outside frame measurement in order to install them on the axle correctly.
7. **How to Determine the Trailing Arm Starting Angle**  
The starting angle is the position of the spindle in reference to the trailer frame. In order to make it simpler to select the starting angle for your Torflex axle, consult the tables which appear at the bottom of each Torflex axle page.

## How to Order Torflex Axles:

Our part number system for Torflex Axles is very similar to that of the tubular axles. Please place your order according to the description based on the following information/example:

- EX:** 12TF70-865E-EZ #12 Torflex, 7,000 lb., 8 Bolt, 6.5" Bolt Pattern, Electric Brake, E-Z Lube
- 12TF:** Model of Torflex Axle (#8, #9, #10, #11, #12, or #13)
- 70:** Capacity of Torflex Axle (70 = 7,000 lb. capacity)
- 865:** 8 Bolt, 6.5" Bolt Pattern
- E:** Type of Brake, if any (I = Idler, E = Electric, H = Single Serve Hydraulic, HY = Duo-Serve Hydraulic)
- EZ:** Type of Lube (EZ = E-Z Lube, OIL = Oil)

It is also necessary that you give us the outside dimension of your frame and the starting angle of the trailing arm.

## How to Install Torflex Axles

**Step 1:**

First decide where to place the centerline of the axle(s) on the trailer. This position will determine the final axle loading as well as the hitch load.

**Step 2:**

Determine the method of attachment you wish to use.

- A. For structural tube frame rails, refer to Figure 1 for recommended attachment.
- B. For "C" channel or "I" beam type frame, refer to Figure 2.

**Step 3:**

Once the method of attachment is decided, the axle(s) must be carefully aligned on the trailer frame. The axle centerline must be perpendicular to the longitudinal centerline of the trailer. Misalignment of the axle(s) can cause poor tracking and accelerated tire wear.

**Step 4: Attachment to Structural Tube Type Frames**

Dexter Axle recommends the use of side mounting hangers when attaching axles to tubular type frames. These hangers are included in the side mount AP kits listed in Chart 2.

- A. Refer to Chart 1 to find the mounting bracket dimensions of your axle(s). This chart shows the dimensions from the wheel center to the bolt holes of the brackets.
- B. If you wish to pre-weld the side mount hangers to the frame rails, see Figure 1 for the appropriate spacing.
- C. A convenient way to install the side mount hanger is to preassemble the hangers to the axle when using the hardware provided in the AP kit. Make sure the bolts are tightened to the torque specifications shown in Chart 2. Position the axle assembly on the frame rails in the desired location and weld the side mount hangers to the frame.

**Step 5: Attachment to "C" Channel or "I" Beam Type Frames**

- A. Refer to Chart 1 to find the mounting brackets dimensions of your axle(s). This chart shows the dimensions from the wheel center to the bolt holes of the brackets.
- B. Lay-out the bolt hole locations on the bottom flanges of the frame rails. Make sure that the hole pattern matches the mounting brackets of your axles and is properly oriented to allow proper alignment of the axle(s).
- C. An alternate method for determining hole location is to position the axle assembly on the frame rails, align it perpendicular to the trailer centerline, clamp in place and transfer the holes directly from the brackets.
- D. Drill the holes through the frame rails and attach the axle using the hardware provided in the AP kit. Tighten the bolts to the torque specified.

**NOTE:** In the unlikely event a Torflex Axle must be replaced during the warranty period, Dexter Axle cannot assume responsibility for additional costs incurred for removal and re-installation of axles that have been welded directly to the frame.



**CHART 1**  
**BRACKET DIMENSIONS**  
MOUNTING HOLE TO WHEEL CENTER -- DIM. "X" (INCHES)

TORFLEX AXLE SIZE	START ANGLE OF TRAILING ARM												MOUNTING HOLE SPACING (INCHES)	
	45° DN		22.5° DN		10° DN		0°		10° UP		22.5° UP			
	NO LOAD	FULL LOAD	NO LOAD	FULL LOAD	NO LOAD	FULL LOAD	NO LOAD	FULL LOAD	NO LOAD	FULL LOAD	NO LOAD	FULL LOAD	DIM "D" (TOP)	DIM "E" (SIDE)
#9	6.6	8.0	7.9	8.4	8.3	8.2	8.4	7.9	8.3	7.5	7.9	6.7	7.75	8.0
#10	6.7	8.1	8.0	8.5	8.4	8.3	8.5	7.9	8.4	7.3	8.0	6.1	8.0	8.0
#11 (6" ARM)	7.7	8.6	9.0	9.5	9.4	9.5	9.5	9.4	9.4	9.1	9.0	8.5	9.0	9.5
#11 (8" ARM)	9.2	10.7	10.9	11.4	11.4	11.5	11.5	11.2	11.4	10.7	10.9	9.6	9.0	9.5
#12 (6" ARM)	7.7	8.9	9.0	9.5	9.4	9.4	9.5	9.1	9.4	8.8	9.0	7.8	9.0	9.5
#13	7.8	9.2	9.1	9.6	9.5	9.5	9.6	9.2	9.5	8.7	9.1	7.8	10.56	10.56

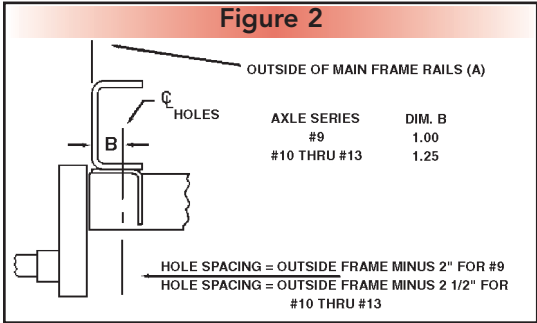
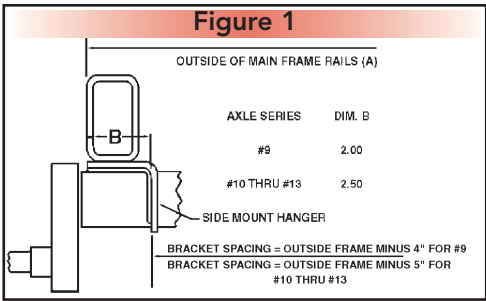
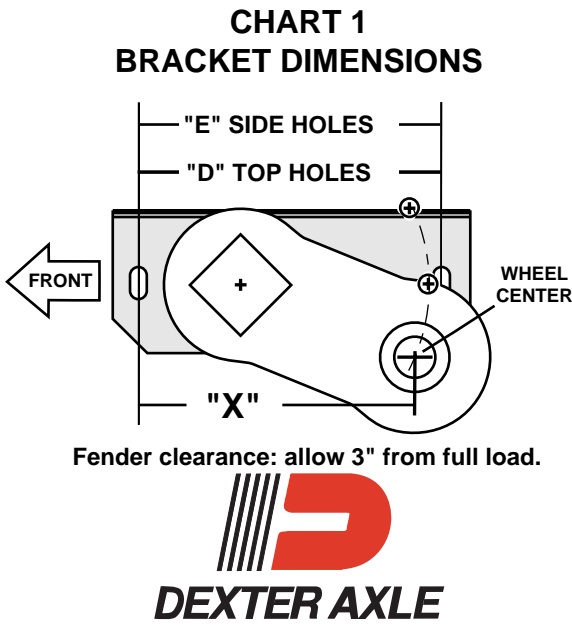

Axles will be built with the distance between the brackets equal to bracket spacing as determined by the above equation, (Figure 1), which uses the outside of frame. The tolerance on this spacing will be 1/8".

Locate the outboard face of the side mounting hanger to the same dimension as bracket spacing but with a tolerance of 1/8". The "B" dimension must not be exceeded to insure that the arms will not hit the side of the frame rails.

Axles will be built with the distance between the bracket mounting holes equal to the hole spacing as determined by the equation, (Figure 2), which uses the outside of frame.

Set hole spacings on the trailer to the same dimension. The "B" dimension must not be exceeded to insure that the arms will not hit the side of the frame rails.

Side mount hangers should be welded to frame with three fillet welds 2 1/2" long on both sides of hanger and a fillet weld on each end in accordance with American Welding Society D1.1 Structural Welding Code.

Side mount hangers and fasteners for mounting axle are provided in AP (attaching parts) kits given in Chart 2. Torque fasteners to levels specified. Install fasteners so that bolt head is against side mount hangers with washer and not against mounting bracket which is welded to the axle.

**CHART 2**  
**ATTACHING PARTS KITS**  
**TORQUE SPECIFICATIONS**

AXLE SIZE	AP KIT		BOLT SIZE	TORQUE LB-FT
	TOP MOUNT	SIDE MOUNT		
#9	AP-161	AP-165	1/2"	70-80
#10	AP-148	AP-166	5/8"	145-155
#11	AP-148	AP-167	5/8"	145-155
#12	AP-148	AP-168	5/8"	145-155
#13	AP-148	AP-169	5/8"	145-155



**SPECIFICATIONS**

**Suspension:** Features an independent suspension cushioned with rubber, providing a smooth, quiet ride with no transfer of road shock from one wheel to the other. (No springs required)

**Bolt Pattern Options:** • 4 on 4" • 5 on 4.5"

5 Bolt available with:

- 5 1/2" Hub Flange – For 8" - 12" Wheels
- 6 1/2" Hub Flange – For 12" - 15" Wheels

**Brake Options:** • Available as Idler only

**Spindles:** Standard BTR 1 1/16", L44649 Inner/Outer Bearings.

**Lubrication:** • Grease • E-Z Lube

**Wheel Assemblies:** See Section E

**Replacement Parts:**

**Hub Parts:** See Page B-12 and B-13

**Brakes:** Available as Idler only

**Axle Beams:** See Page B-2

#8 Torflex Axle Assemblies		
Axle Type	4 on 4"	5 on 4 1/2"
Idler	8TF9-440I	8TF9-545I
Idler w/ E-Z Lube	8TF9-440I-EZ	8TF9-545I-EZ

**#8 Torflex Mounting Kit & Axle Options**

Part No.	Ref No.	Type
XTRA-HF-8TF	044825	EXTRA CHARGE (PER AXLE) FOR AXLES OVER 96" HUB FACE
AP165	046910	WELD ON MOUNTING KIT FOR #8 TORFLEX AXLES

For information on ordering and installing Torflex axles, see pages A-25 thru A-27.  
For specific ordering information, please call your nearest Branch.

# #8 TORFLEX SPECIFICATIONS



ASSEMBLIES

## Mounting Details

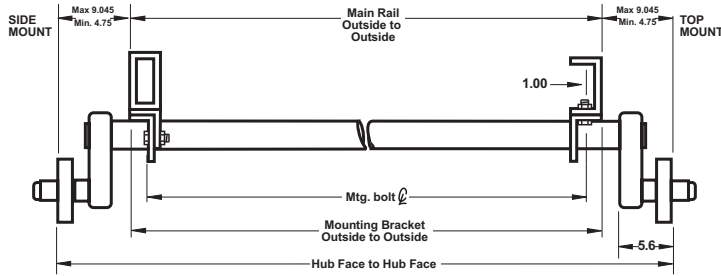

Difference between hubface and outside mounting brackets

**Minimum**  
9.50" (4.25" per side)

**Maximum**  
18.08" (9.04" per side)

Note: Minimums are based on manufacturing tolerances only. Some tire and wheel combinations may create interference.

## FULL LOAD DIMENSIONS

Dimensions are for low profile, top mount only. High profile brackets are .88" higher. Side mount is .25" higher.

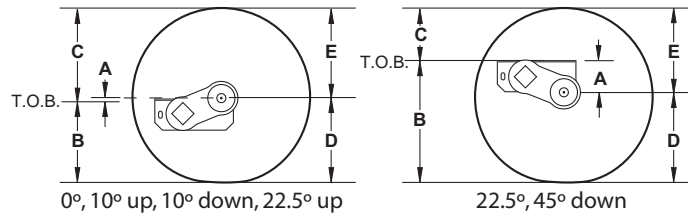

A = Center Line of spindle to top of bracket, B = Top of bracket to ground, C = Top of bracket to top of tire, D = Center Line of spindle to ground, E = Center Line of spindle to top of tire.

## START ANGLE

Tire	0°			10° Up			22.5° Up			10° Down			45° Down			22.5° Down				
	A	B	C	A	B	C	A	B	C	A	B	C	A	B	C	A	B	C	D	E
4.80-8	.5	7.1	8.8	1.2	6.4	9.5	1.8	5.8	9.5	.1	7.3	8.6	2.5	10.1	5.8	1.0	8.6	7.3	7.6	8.3
4.80-12	.5	9.0	10.8	1.2	8.3	11.5	1.8	7.7	12.1	.1	9.2	10.6	2.5	12.0	7.8	1.0	10.5	9.3	9.5	10.3
20.5X8.0-10	.5	7.2	10.7	1.2	8.5	11.4	1.8	7.9	12.0	.1	9.4	10.5	2.5	12.2	7.7	1.0	10.7	9.2	9.7	10.2
B78-13	.5	10.8	12.7	1.2	10.1	13.4	1.8	9.5	14.0	.1	11.0	12.5	2.5	13.8	9.7	1.0	12.3	11.2	11.3	12.2

## ARTICULATION DIMENSIONS

ALLOW 3" BUMP CLEARANCE FROM FULL LOAD.

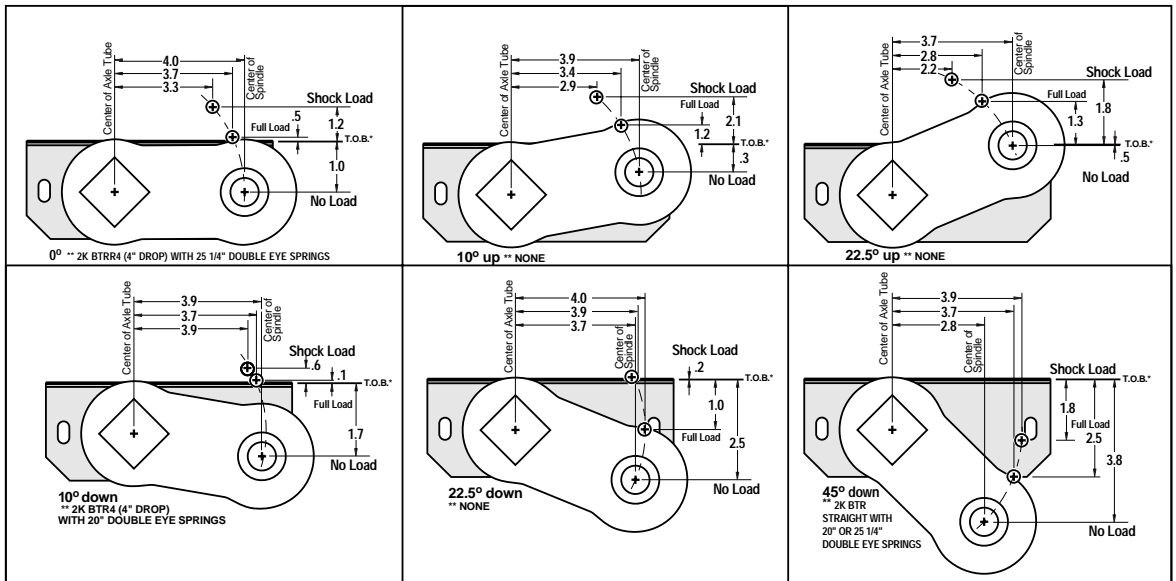

\* TOP OF BRACKET  
\*\* DENOTES RIDE HEIGHT EQUAL TO TUBULAR SPRUNG AXLES.



## SPECIFICATIONS

**Suspension:** Features an independent suspension cushioned with rubber, providing a smooth, quiet ride with no transfer of road shock from one wheel to the other. (No springs required)

**Bolt Pattern Options:** • 4 on 4" • 5 on 4.5"

5 Bolt available with:

- 5 1/2" Hub Flange – For 8" - 12" Wheels
- 6 1/2" Hub Flange – For 12" - 15" Wheels

**Brake Options:**

- 7" x 1 1/4" – Electric
- 7" x 1 3/4" – Hydraulic Uni-Servo

**Spindles:** Standard BTR 1 1/16",  
L44649 Inner/Outer Bearings.

**Lubrication:** • Grease • E-Z Lube

**Wheel Assemblies:** See Section E

### Replacement Parts:

**Hubs:** See Page B-12 and B-13

**Hub/Drums:** See Page B-18 and B-20

**Brakes:** See Page C-9 (Electric), Page C-25 (Hydraulic)

**Axle Beams:** See Page B-3

### #9 Torflex Axle Assemblies

Axle Type	4 on 4"	5 on 4 1/2"
Idler	9TF20-440I	9TF20-545I
Idler w/ E-Z Lube	9TF20-440I-EZ	9TF20-545I-EZ
Electric	9TF20-440E	9TF20-545E
Electric w/ E-Z Lube	9TF20-440E-EZ	9TF20-545E-EZ
Single Servo Hydraulic	9TF20-440H	9TF20-545H
Hydraulic w/ E-Z Lube	9TF20-440H-EZ	9TF20-545H-EZ

### #9 Torflex Mounting Kit & Axle Options

Part No.	Ref. No.	Type
XTRA-HF-9TF	046825	EXTRA CHARGE (PER AXLE) FOR AXLES OVER 96" HUB FACE
AP165	046910	WELD ON MOUNTING KIT FOR #9 TORFLEX AXLES

# #9 TORFLEX SPECIFICATIONS



## MOUNTING DETAILS

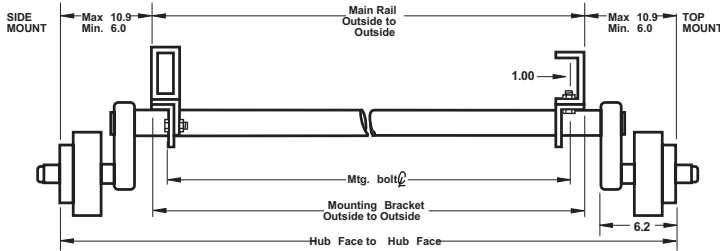

**Difference between hub face and outside mounting brackets**

**Minimum**  
12.00" (6" per side)

**Maximum**  
21.80" (10.9" per side)

Note: Minimums are based on manufacturing tolerances only. Some tire and wheel combinations may create interference.

## FULL LOAD DIMENSIONS

Dimensions are for low profile, top mount only. High profile brackets are .88" higher. Side mount is .25" higher.

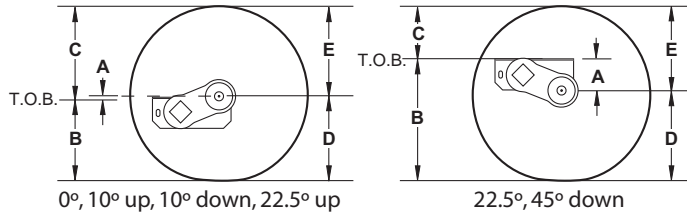

**A** = Center Line of spindle to top of bracket, **B** = Top of bracket to ground, **C** = Top of bracket to top of tire, **D** = Center Line of spindle to ground, **E** = Center Line of spindle to top of tire.

Tire	START ANGLE																			
	0°			10° Up			22.5° Up			10° Down			45° Down			22.5° Down				
	A	B	C	A	B	C	A	B	C	A	B	C	A	B	C	A	B	C	D	E
4.80-8	1.1	6.5	9.4	2.0	5.6	10.3	3.0	4.6	11.3	.2	7.4	8.5	3.4	11.0	4.9	1.2	8.8	7.1	7.6	8.3
4.80-12	1.1	8.4	11.4	2.0	7.5	12.3	3.0	6.5	13.3	.2	9.3	10.5	3.4	12.9	6.9	1.2	10.7	9.1	9.5	10.3
20.5X8.0-10	1.1	8.6	11.3	2.0	7.7	12.2	3.0	6.7	13.2	.2	9.5	10.4	3.4	13.1	6.8	1.2	10.9	9.0	9.7	10.2
B78-13	1.1	10.2	13.3	2.0	9.3	14.2	3.0	8.3	15.2	.2	11.1	12.4	3.4	14.7	8.8	1.2	12.5	11.0	11.3	12.2

## ARTICULATION DIMENSIONS

ALLOW 3" BUMP CLEARANCE FROM FULL LOAD.

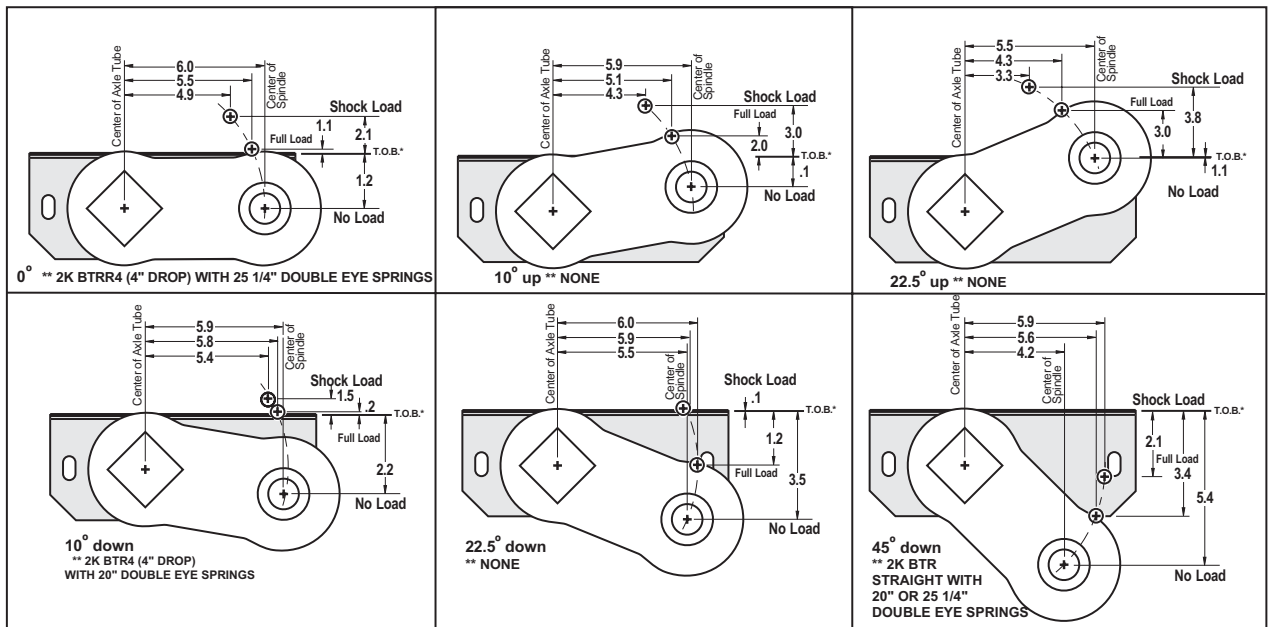

\* TOP OF BRACKET  
\*\* DENOTES RIDE HEIGHT EQUAL TO TUBULAR SPRUNG AXLES.



AXLE  
ASSEMBLIES

**SPECIFICATIONS**

**Suspension:** Features an independent suspension cushioned with rubber, providing a smooth, quiet ride with no transfer of road shock from one wheel to the other. (No springs required)

**Bolt Pattern Options:**

- 5 on 4 1/2" • 5 on 4 3/4" • 5 on 5"
- 5 on 5 1/2" • 6 on 5 1/2"

**Brake Options:** With or without parking feature.

- 10 x 2 1/4" Electric
- 10 x 2 1/4" Hydraulic (Uni-Servo & Freebacking)

**Spindles:** TTH (#84 Spindle)

L68149 Inner, L44649 Outer Bearings

**Lubrication:** • Grease • E-Z Lube • Nev-R-Lube

**Wheel Assemblies:** See Section E

**Replacement Parts:**

- Hubs:** See Page B-14
- Hub/Drums:** See Page B-21, B-33(Nev-R-Lube)
- Brakes:** See Page C-10 (Electric),  
Page C-26 (Hydraulic)
- Axle Beams:** See Page B-3

**# 10 Torflex Axle Assemblies**

Axle Type	5 on 4 1/2"	5 on 4 3/4"	5 on 5"	5 on 5 1/2"	6 on 5 1/2"
Idler	10TF35-545I	10TF35-5475I	10TF35-550I	10TF35-555I	10TF35-655I
Idler w/ E-Z Lube	10TF35-545I-EZ	10TF35-5475I-EZ	10TF35-550I-EZ	10TF35-555I-EZ	10TF35-655I-EZ
Electric	10TF35-545E	10TF35-5475E	10TF35-550E	10TF35-555E	10TF35-655E
Electric w/ E-Z Lube	10TF35-545E-EZ	10TF35-5475E-EZ	10TF35-550E-EZ	10TF35-555E-EZ	10TF35-655E-EZ
Electric w/ Nev-R-Lube	N/A	N/A	N/A	N/A	10TF35-655E-NL
Single Servo Hydraulic	10TF35-545H	10TF35-5475H	10TF35-550H	10TF35-555H	10TF35-655H
Single Servo Hydraulic w/ E-Z Lube	10TF35-545H-EZ	10TF35-5475H-EZ	10TF35-550H-EZ	10TF35-555H-EZ	10TF35-655H-EZ
Single Servo Hydraulic w/ Nev-R-Lube	N/A	N/A	N/A	N/A	10TF35-655H-NL
Hydraulic Freeback	10TF35-545HFB	10TF35-5475HFB	10TF35-550HFB	10TF35-555HFB	10TF35-655HFB
Hydraulic Freeback w/ E-Z Lube	10TF35-545HFB-EZ	10TF35-5475HFB-EZ	10TF35-550HFB-EZ	10TF35-555HFB-EZ	10TF35-655HFB-EZ
Hydraulic Freeback w/ Nev-R-Lube	N/A	N/A	N/A	N/A	10TF35-655HFB-NL

**#10 Torflex Mounting Kit & Axle Option**

Part No.	Ref. No.	Type
XTRA-HF-10TF	056225	EXTRA CHARGE (PER AXLE) FOR AXLES WITH OVER 96" HUB FACE
10TF-PWC	056230	EXTRA CHARGE FOR #10 TORFLEX ELECTRIC W/ PWC OPTION INSTALLED
AP166	056310	WELD ON MOUNTING BRACKET KIT FOR #10 TORFLEX AXLE

For information on ordering and installing Torflex axles, see pages A-25 thru A-27.  
For specific ordering information, please call your nearest Branch.



# #10 TORFLEX SPECIFICATIONS



## MOUNTING DETAILS

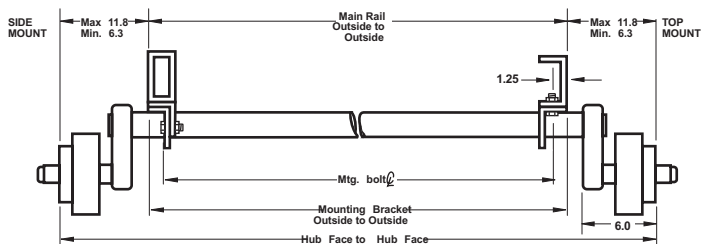

Difference between hubface and outside mounting bracket

**Minimum**  
12.60" (6.3 per side)

**Maximum**  
23.60" (11.8 per side)

Note: Minimums are based on manufacturing tolerances only. Some tire and wheel combinations may create interference.

## FULL LOAD DIMENSIONS

Dimensions are for low profile, top mount only. High profile brackets are .75" higher. Side mount is .25" higher.

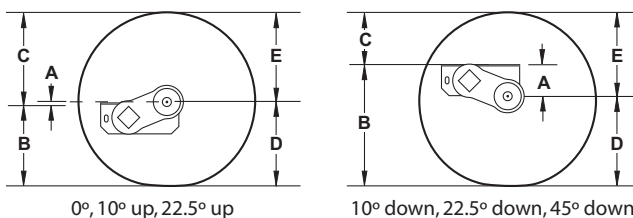

**A** = Center Line of spindle to top of bracket, **B** = Top of bracket to ground, **C** = Top of bracket to top of tire, **D** = Center Line of spindle to ground, **E** = Center Line of spindle to top of tire.

## START ANGLE

Tire	0°			10° Up			22.5° Up			10° Down			45° Down			22.5° Down			(All Angles)	
	A	B	C	A	B	C	A	B	C	A	B	C	A	B	C	A	B	C	D	E
B78-13 ST	1.1	10.2	13.3	2.0	9.3	14.2	3.2	8.1	15.4	0	11.3	12.2	3.6	14.9	8.6	1.3	12.6	10.9	11.3	12.2
G78-14 ST	1.1	11.3	14.6	2.0	10.4	15.5	3.2	9.2	16.7	0	12.4	13.5	3.6	16.0	9.9	1.3	13.7	12.2	12.4	13.5
7.00-15 LT	1.1	12.6	15.9	2.0	11.7	16.8	3.2	10.5	18.0	0	13.7	14.8	3.6	17.3	11.2	1.3	15.0	13.5	13.7	14.8

## ARTICULATION DIMENSIONS

ALLOW 3" BUMP CLEARANCE FROM FULL LOAD.

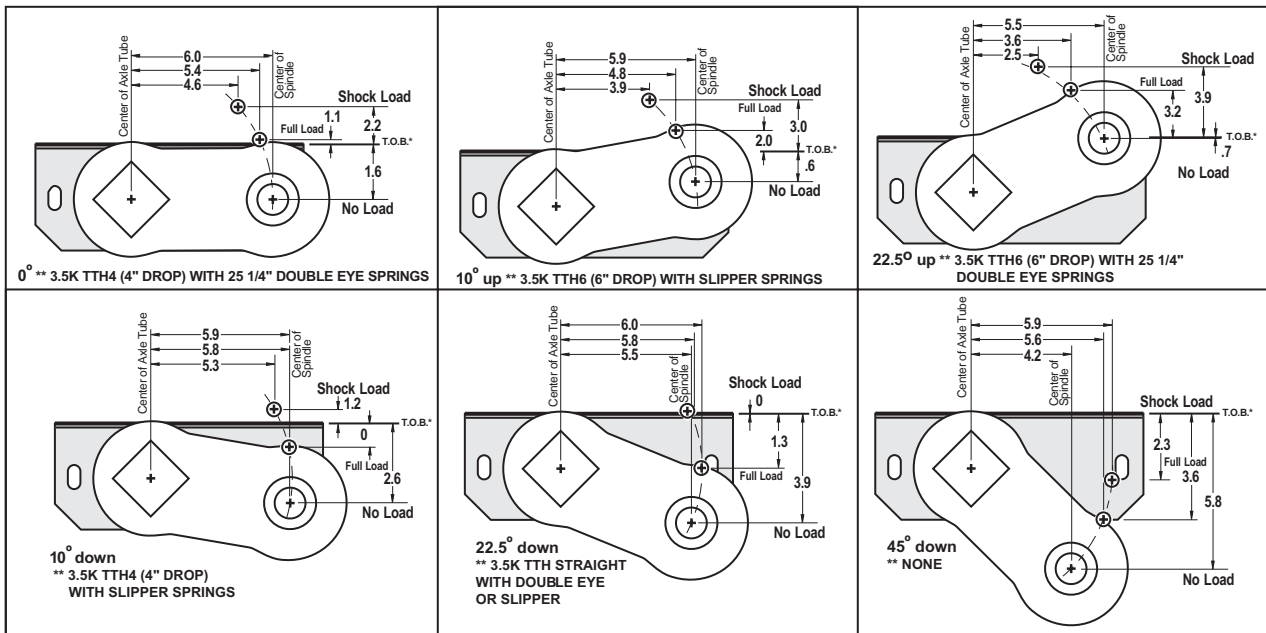

\* TOP OF BRACKET  
\*\* DENOTES RIDE HEIGHT EQUAL TO TUBULAR SPRUNG AXLES.



**SPECIFICATIONS**

**Suspension:** Features an independent suspension cushioned with rubber, providing a smooth, quiet ride with no transfer of road shock from one wheel to the other. (No springs required)

**Bolt Pattern Options:**

- 6 on 5 1/2" • 8 on 6 1/2"
- UTG 5-Spoke, for 14.5" wheels

**Brake Options:**

- With or without parking feature.
- 12 x 2" Electric
- 12 x 2" Hydraulic (Uni-Servo, Freebacking and Duo-Servo)

**Spindles:**

- TTA (#42 Spindle w/2 1/4" seal journal)
- 25580 Inner, LM67048, 15123, or 14125A Outer Bearings

**Lubrication:** • Grease • E-Z Lube

- Oil Bath •Nev-R-Lube

**Wheel Assemblies:** See Section E

**Replacement Parts:**

- Idler Hub:** See Page B-15 and B-16
- Hub/Drums:** See Page B-22 - B-24 B-34(Nev-R-Lube)
- Brakes:** See Page C-11 (Electric), Page C-27 & 28 (Hydraulic)
- Axle Beams:** See Page B-3

#11 Torflex Axle Assemblies			
Axle Type	6 on 5 1/2"	8 on 6 1/2"	UTG 5-SPOKE
<b>Idler</b>			
Std Grease	11TF60-655I	11TF60-865I	11TF60-UTGI
w/ E-Z Lube	11TF60-655I-EZ	11TF60-865I-EZ	11TF60-UTGI-EZ
w/ Oil Bath	N/A	11TF60-865I-OIL	11TF60-UTOI-OIL
<b>Electric</b>			
Std Grease	11TF60-655E	11TF60-865E	11TF60-UTGE
w/ E-Z Lube	11TF60-655E-EZ	11TF60-865E-EZ	11TF60-UTGE-EZ
w/ Nev-R-Lube	11TF60-655E-NL	11TF60-856E-NL	N/A
w/ Oil Bath	N/A	11TF60-865E-OIL	11TF60-UTOE-OIL
<b>Single Servo Hydraulic</b>			
Std Grease	11TF60-655H	11TF60-865H	11TF60-UTGH
w/ E-Z Lube	11TF60-655H-EZ	11TF60-865H-EZ	11TF60-UTGH-EZ
w/ Nev-R-Lube	11TF60-655H-NL	11TF60-865H-NL	N/A
w/ Oil Bath	N/A	11TF60-865H-OIL	11TF60-UTOH-OIL
<b>Single Servo Hydraulic Freeback</b>			
Std Grease	11TF60655HFB	11TF60865HFB	11TF60-UTGHFB
w/ E-Z Lube	11TF60655HFBEZ	11TF60865HFBEZ	11TF60UTGHFBEZ
w/ Nev-R-Lube	11TF60655HFBNL	11TF60865HFBNL	N/A
w/ Oil Bath	N/A	11TF60-865HFBOIL	11TF60-UTOHFBOIL
<b>Duo-Servo Hydraulic</b>			
Std Grease	11TF60-655HY	11TF60-865HY	11TF60-UTGHY
w/ E-Z Lube	11TF60-655HY-EZ	11TF60-865HY-EZ	11TF60-UTGHY-EZ
w/ Nev-R-Lube	11TF60-655HY-NL	11TF60-865HY-NL	N/A
w/ Oil Bath	N/A	11TF60-865HYOIL	11TF60-UTOHYOIL

**#11 Torflex Mounting Kit & Axle Options**

Part No.	Ref. No.	Type
XTRA-HF-11TF	060150	EXTRA CHARGE (PER AXLE) FOR AXLES OVER 96" HUB FACE
11TF-PWC	060160	EXTRA CHARGE FOR #11 TORFLEX ELECTRIC W/ PWC OPTION INSTALLED
AP167	060190	WELD ON MOUNTING BRACKET KIT FOR #11 TORFLEX AXLE

For information on ordering and installing Torflex axles, see pages A-25 thru A-27.  
For specific ordering information, please call your nearest Branch.

# #11 TORFLEX SPECIFICATIONS



ASSEMBLIES

## MOUNTING DETAILS

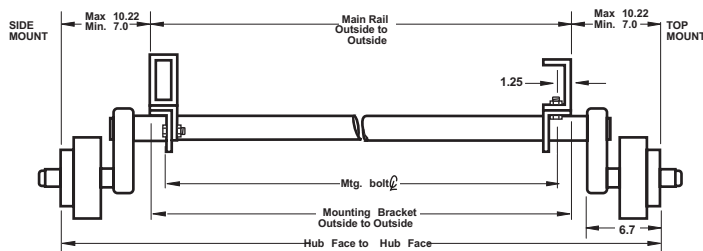

Difference between hubface and outside mounting bracket

**Minimum**

14.00" (7" per side)

**Maximum**

5200 lb. - 23.60" (11.8 per side)

6000 lb. - 20.45" (10.22 per side)

Note: Minimums are based on manufacturing tolerances only. Some tire and wheel combinations may create interference.

## FULL LOAD DIMENSIONS

Dimensions are for low profile, top mount only. High profile brackets are .75" higher. Side mount is .25" higher.

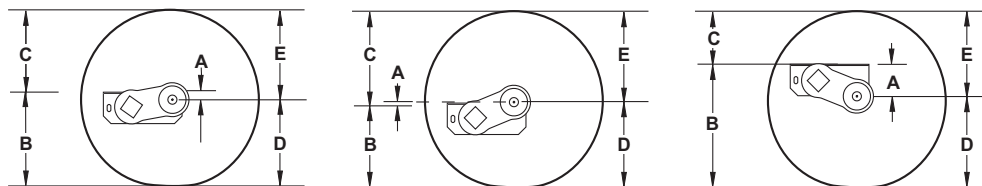

10° down

0°, 10°, 22.5° up

22.5°, 45° down

A = Center Line of spindle to top of bracket, B = Top of bracket to ground, C = Top of bracket to top of tire, D = Center Line of spindle to ground, E = Center Line of spindle to top of tire.

## START ANGLE

Tire	0°			10° Up			22.5° Up			45° Down			22.5° Down			10° Down			(All Angles)	
	A	B	C	A	B	C	A	B	C	A	B	C	A	B	C	A	B	C	D	E
G78-14ST	.5	11.9	14.0	1.4	11.0	14.9	2.4	10.0	15.9	4.1	16.5	9.4	1.8	14.2	11.7	.5	12.9	13.0	12.4	13.5
7.00-15LT	.5	13.2	15.3	1.4	12.3	16.2	2.4	11.3	17.2	4.1	17.8	10.7	1.8	15.5	13.0	.5	14.2	14.3	13.7	14.8

## ARTICULATION DIMENSIONS

ALLOW 3" BUMP CLEARANCE FROM FULL LOAD.

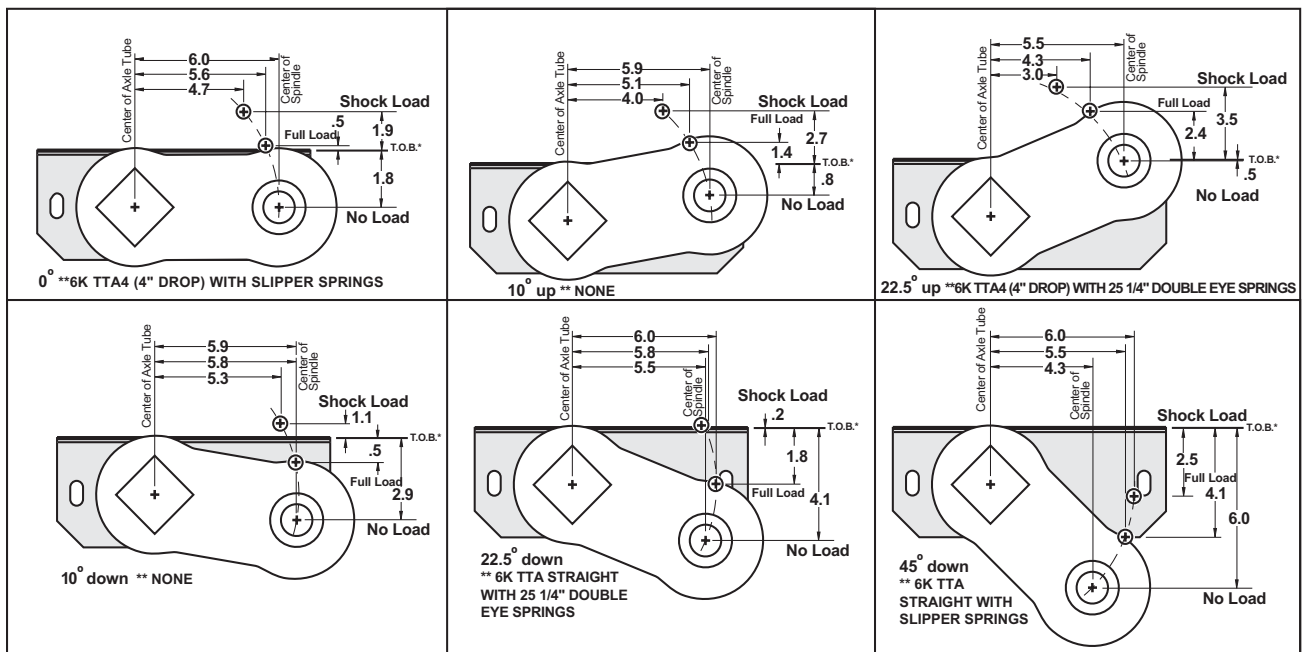

\* TOP OF BRACKET

\*\* DENOTES RIDE HEIGHT EQUAL TO TUBULAR SPRUNG AXLES.



## SPECIFICATIONS

**Suspension:** Features an independent suspension cushioned with rubber, providing a smooth, quiet ride with no transfer of road shock from one wheel to the other. (No springs required)

**Bolt Pattern Options:**

- #12 • 8 on 6 1/2" • UTG 5-Spoke
- #12V • 8 on 6 1/2" (9/16" Studs Standard or optional 5/8")

**Brake Options:**

- #12 With or without parking feature.
  - 12 x 2 " Electric
  - 12 x 2 " Hydraulic (Uni-Servo, Freebacking and Duo-Servo)
- #12V • 12 1/4" x 2 1/2" Electric Only

**Spindles:**

- #12 UTA (#42 Spindle w/2 1/4" seal journal) 25580 Inner, LM67048, 15123, or 14125A Outer Bearings
- #12V 25580 Inner, 02475 Outer Bearings

**Lubrication:**

- #12 • Grease • E-Z Lube • Oil Bath • Nev-R-Lube
- #12V • Grease • E-Z Lube • Oil Bath

**Wheel Assemblies:** See Section E

**Replacement Parts:**

- Idler Hub:** #12 - See Page B-16  
#12V - N/A
- Hub/Drums:** #12 - See Page B-23 & B-24, B-34(Nev-R-Lube)  
#12V - See Page B-25
- Brakes:** #12 - See Page C-11 (Electric),  
Page C-27 & C-28 (Hydraulic)  
#12V - See Page C-14 (Electric)
- Axle Beams:** #12 & #12V - See Page B-3

**#12 Torflex Axle Assemblies - 7,000 lb**

Axle Type:	8 on 6 1/2"	UTG 5-SPOKE
<b>Idler</b>		
Std Grease	12TF70-865I	12TF70-UTGI
w/ E-Z Lube	12TF70-865I-EZ	12TF70-UTGI-EZ
w/ Oil Bath	12TF70-865I-OIL	12TF70-UTOI-OIL
<b>Electric</b>		
Std Grease	12TF70-865E	12TF70-UTGE
w/ E-Z Lube	12TF70-865E-EZ	12TF70-UTGE-EZ
w/ Nev-R-Lube	12TF70-865E-NL	N/A
w/ Oil Bath	12TF70-865E-OIL	12TF70-UTOE-OIL
<b>Single Servo Hydraulic</b>		
Std Grease	12TF70-865H	12TF70-UTGH
w/ E-Z Lube	12TF70-865H-EZ	12TF70-UTGH-EZ
w/ Nev-R-Lube	12TF70-865H-NL	N/A
W/ Oil Bath	12TF70-865H-OIL	12TF70-UTOH-OIL
<b>Single Servo Hydraulic Freeback</b>		
Std Grease	12TF70-865HFB	12TF70-UTGHFB
w/ E-Z Lube	12TF70-865HFBEZ	12TF70-UTGHFB-EZ
w/ Nev-R-Lube	12TF70-865HFBNL	N/A
w/ Oil Bath	12TF70-865HFBOIL	12TF70-UTOHFBOIL
<b>Duo-Servo Hydraulic</b>		
Std Grease	12TF70-865HY	12TF70-UTGHY
w/ E-Z Lube	12TF70-865HY-EZ	12TF70-UTGHY-EZ
w/ Nev-R-Lube	12TF70-865HY-NL	N/A
w/ Oil Bath	12TF70-865HYOIL	12TF70-UTOHYOIL

**#12V Torflex Axle Assemblies - 7,200 lb**

<b>Electric</b>		
Std Grease	12TF72-865E	N/A
w/ E-Z Lube	12TF72-865E-EZ	N/A
w/ Oil Bath	12TF72-865E-OIL	N/A

**#12 & 12V Torflex Mounting Kit & Axle Options**

Part No.	Ref. No.	Type
XTRA-HF-12TF	063275	EXTRA CHARGE (PER AXLE) FOR AXLES OVER 96" HUB FACE
12TF-PWC	063280	EXTRA CHARGE FOR #12 TORFLEX ELECTRIC W/ PWC OPTION INSTALLED
AP168	063290	WELD ON MOUNTING BRACKET KIT FOR #12 TORFLEX AXLE

For information on ordering and installing Torflex axles, see pages A-25 thru A-27.  
For specific ordering information, please call your nearest Branch.

# #12 & #12V TORFLEX SPECIFICATIONS



ASSEMBLIES

## MOUNTING DETAILS

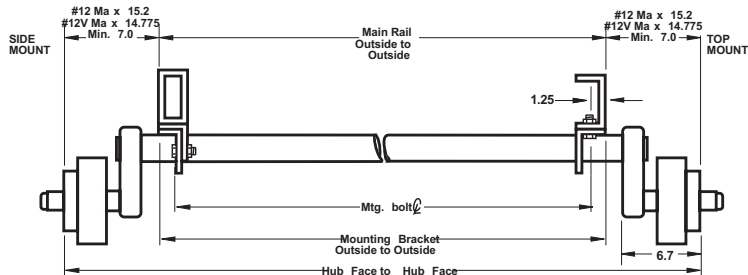

**Difference between hubface and outside mounting bracket**

**Minimum**  
14.00" (7" per side)

**Maximum**  
#12 - 30.40" (15.2" per side)  
#12V - 29.55" (14.775" per side)

Note: Minimums are based on manufacturing tolerances only. Some tire and wheel combinations may create interference.

## FULL LOAD DIMENSIONS

Dimensions are for low profile, top mount only. High profile brackets are .75" higher. Side mount is .31" higher.

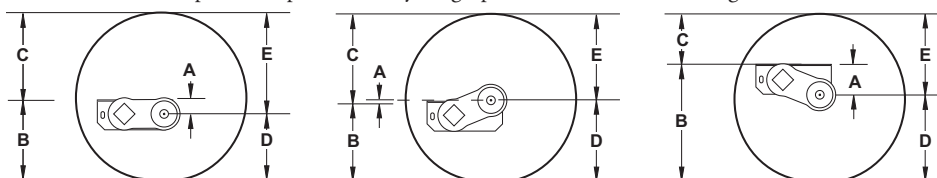

0°, 10° down

10°, 22.5° up

22.5°, 45° down

**A** = Center Line of spindle to top of bracket, **B** = Top of bracket to ground, **C** = Top of bracket to top of tire, **D** = Center Line of spindle to ground, **E** = Center Line of spindle to top of tire.

## START ANGLE

Tire	45° Down			22.5° Down			10° Down			0°			10° Up			22.5° Up			(All Angles)	
	A	B	C	A	B	C	A	B	C	A	B	C	A	B	C	A	B	C	D	E
7.50-16 LT	4.5	19.6	11.4	2.5	17.6		1.0	16.1	14.9	.1	15.2	15.8	.9	14.2	16.8	2.1	13.0	18.0	15.1	15.9
9.50-16.5 LT	4.5	18.7	10.8	2.5	16.7	12.8	1.0	15.2	14.3	.1	14.3	15.2	.9	13.3	16.2	2.1	12.1	17.4	14.2	15.3

## ARTICULATION DIMENSIONS

ALLOW 3" BUMP CLEARANCE FROM FULL LOAD.

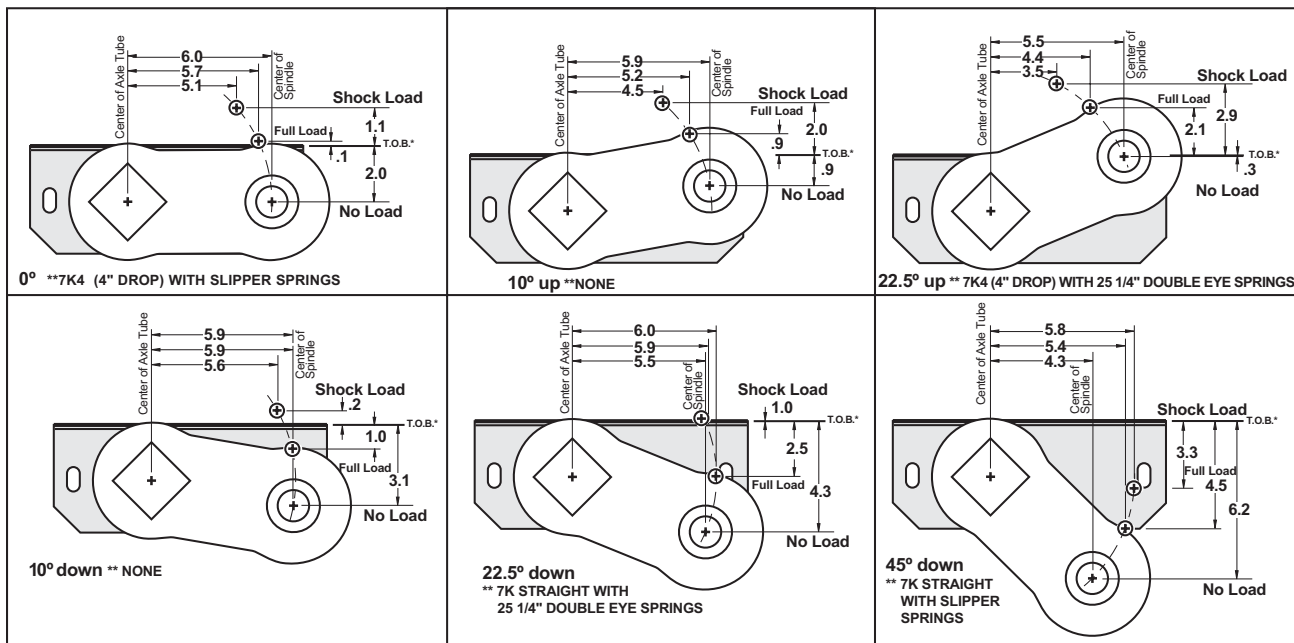

\* TOP OF BRACKET

\*\* DENOTES RIDE HEIGHT EQUAL TO TUBULAR SPRUNG AXLES.



**SPECIFICATIONS**

**Suspension:** Features an independent suspension cushioned with rubber, providing a smooth, quiet ride with no transfer of road shock from one wheel to the other. (No springs required)

**Brake Options:** (Forward Self-Adjusting)

- 12 1/4 X 3 3/8" Electric
- 12 1/4 X 3 3/8" Hydraulic (Duo-Servo Standard, Optional Uni-Servo) with or without parking feature
- ABS Equipped options for hydraulic brakes

**Bolt Pattern Options:**

- 8 on 6 1/2" (9/16" Studs Standard or Optional 5/8")

**Spindles:** 25580 Inner, 02475 Outer Bearings

**Lubrication:** • Oil Bath • E-Z Lube • Nev-R-Lube

**Wheel Assemblies:** See Section E

**Replacement Parts:**

- Idler Hub:** See Page B-17
- Hub/Drums:** See Page B-27, B-34(Nev-R-Lube)
- Brakes:** See Page C-15 (Electric),  
Page C-29 (Hydraulic)
- Axle Beams:** See Page B-3

**#13 Torflex Axle Assemblies**

Axle Type	8 on 6 1/2"
Idler Oil Bath	13TF80-865I
Idler w/ E-Z Lube	13TF80-865I-EZ
Electric Oil Bath	13TF80-865E
Electric w/ E-Z Lube	13TF80-865E-EZ
Electric w/ Nev-R-Lube	13TF80-865E-NL
Duo-Servo Hydraulic, Oil Bath	13TF80-865HY
Duo-Servo Hydraulic w/ E-Z Lube	13TF80-865HY-EZ
Duo-Servo Hydraulic w/ Nev-R-Lube	13TF80-865HY-NL

**#13 Torflex Mounting Kit & Axle Options**

Part No.	Ref. No.	Type
XTRA-HF-13TF	064625	EXTRA CHARGE (PER AXLE) FOR AXLES OVER 96" HUB FACE
13TF-HYD-PARK	064800	HYDRAULIC BRAKES W/ PARK, ADD TO #13 TORFLEX HYDRAULIC BRAKE AXLE PRICE
13TF-PWC	064850	EXTRA CHARGE FOR #13 TORFLEX ELECTRIC W/ PWC OPTION INSTALLED
13TF-ADD-HYABS	064860	EXTRA CHARGE (PER AXLE) FOR HYDRAULIC BRAKE AXLES W/ ABS SENSORS & TONE RINGS INSTALLED
AP169	064900	WELD ON MOUNTING BRACKET KIT FOR #13 TORFLEX AXLES

For information on ordering and installing Torflex axles, see pages A-25 thru A-27.  
For specific ordering information, please call your nearest Branch.

# #13 TORFLEX SPECIFICATIONS

## MOUNTING DETAILS

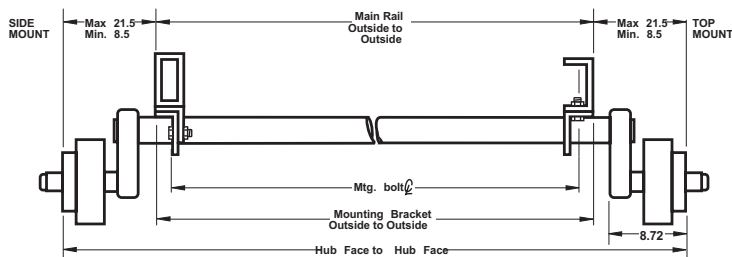

Difference between hub face and outside mounting bracket

**Minimum**  
17.00" (8.5" per side)

**Maximum**  
43.00" (21.5" per side)

Note: Minimums are based on manufacturing tolerances only. Some tire and wheel combinations may create interference.

## FULL LOAD DIMENSIONS

Dimensions are for low profile, top mount only. Side mount is .31" higher.

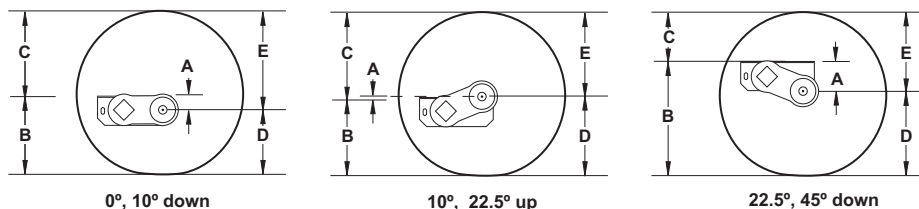

A = Center Line of spindle to top of bracket, B = Top of bracket to ground, C = Top of bracket to top of tire, D = Center Line of spindle to ground, E = Center Line of spindle to top of tire.

## START ANGLE

Tire	0°			10° Up			22.5° Up			45° Down			22.5° Down			10° Down			(All Angles)	
	A	B	C	A	B	C	A	B	C	A	B	C	A	B	C	A	B	C	D	E
12-16.5 LT	.2	15.1	15.6	.9	14.0	16.7	2.0	12.9	17.8	4.5	19.4	11.3	2.3	17.2	13.5	1.0	15.9	14.8	14.9	15.8
9.50-16.5 LT	.2	14.4	15.2	.9	13.3	16.3	2.0	12.2	17.4	4.5	18.7	10.9	2.3	16.5	13.1	1.0	15.2	14.4	14.2	15.4
7.50-16 LT	.2	15.3	15.8	.9	14.2	16.9	2.0	13.1	18.0	4.5	19.6	11.5	2.3	17.4	13.7	1.0	16.1	15.0	15.1	16.0
9.00-15 TR	.2	16.5	17.2	.9	15.4	18.3	2.0	14.3	19.4	4.5	20.8	12.9	2.3	18.6	15.1	1.0	17.3	16.4	16.3	17.4

## ARTICULATION DIMENSIONS

1/3" BUMP CLEARANCE FROM FULL LOAD.

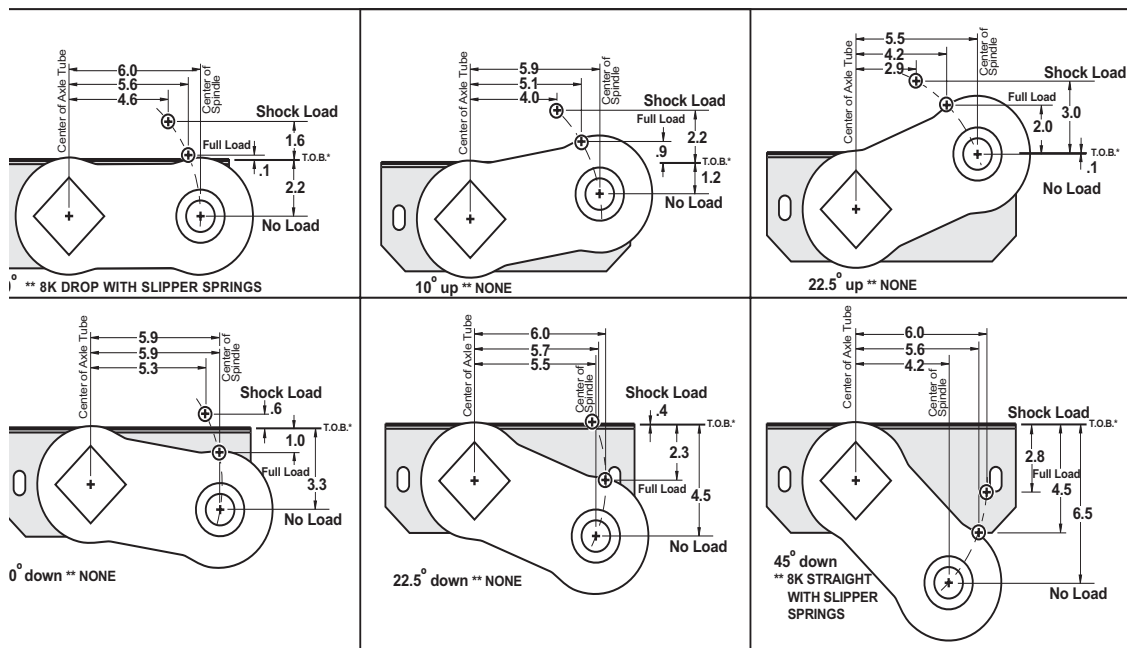

<sup>1</sup> OF BRACKET  
NOTES RIDE HEIGHT EQUAL TO TUBULAR SPRUNG AXLES.



**TORFLEX**  
RUBBER TORSION SUSPENSION AXLES

General Duty 9,000 lb. - 10,000 lb.  
Heavy Duty 9,000 lb. - 10,000 lb.



**SPECIFICATIONS**

**Suspension:** Features an independent suspension cushioned with rubber, providing a smooth, quiet ride with no transfer of road shock from one wheel to the other. (No springs required)

**Brake Options:** (Forward Self Adjusting)

- #10K GD
  - 12 1/4 x 3 3/8" Electric
  - 12 1/4 x 3 3/8" Hydraulic: Duo-Servo, Standard; (Optional Uni-Servo) with or without parking feature
  - ABS Equipped Option for Hydraulic Brakes
- #10K HD
  - 12 1/4 x 4" Electric
  - 12 1/4 x 4" Hydraulic: Duo-Servo, Standard; (Optional Uni-Servo) with or without parking feature
  - ABS Equipped Option for Hydraulic Brakes

**Bolt Pattern Options:**

- #10K GD & HD • 8 on 6 1/2"

**Spindles:**

- #10K GD • 387A Inner, 25580 Outer Bearings
- #10K HD • 395S Inner, 387A Outer Bearings

**Lubrication:**

- #10K GD & HD • Oil Bath

**Wheel Assemblies:** See Section E

**#10K General Duty Torflex Axle Assemblies**

Axle Type	8 on 6 1/2"	ABS Equipped, 8 on 6 1/2"
Electric	10GDTF-865E	N/A
Duo-Servo Hydraulic	10GDTF-865HY	10GDTF-865HABS

**#10K Heavy Duty Torflex Axle Assemblies**

Axle Type	8 on 6 1/2"	ABS Equipped, 8 on 6 1/2"
Electric	10HDTF-865E	N/A
Duo-Servo Hydraulic	10HDTF-865HY	10HDTF-865HABS

**Replacement Parts:**

**Hub/Drums:** 10K GD & HD

See Page B-29, B-30

**Brakes:**  
 10K GD - See Page C-16 (Electric),  
 Page C-30 (Hydraulic)  
 10K HD - See page C-18 (Electric),  
 Page C-31 (Hydraulic)

**10K Torflex Mounting Kit and Axle Options**

Part No.	Ref. No.	Description
XTRA-HF-10KTF	064965	EXTRA CHARGE (PER AXLE) FOR AXLES OVER 80" HUB FACE
10KTF-HYD-PARK	064970	HYDRAULIC BRAKES W/ PARK, ADD TO 10K TORFLEX HYDRAULIC BRAKE AXLE PRICE
10KTF-PWC	064975	EXTRA CHARGE FOR 10K TORFLEX ELECTRIC W/ PWC OPTION INSTALLED
AP169	064900	WELD-ON MOUNTING KIT FOR 10K TORFLEX AXLE

For information on ordering and installing Torflex axles, see pages A-25 thru A-27.  
 For specific ordering information, please call your nearest Branch.



## 10K TORFLEX SPECIFICATIONS



ASSEMBLIES

### MOUNTING DETAILS

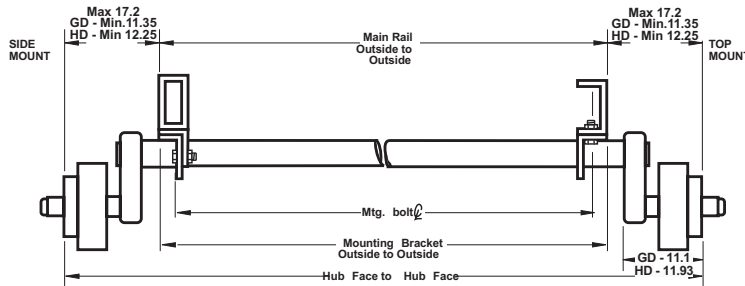

Difference between hub face and mounting brackets

- Minimum**  
 10K GD - 22.70" (11.35" per side)  
 10K HD - 24.50" (12.25" per side)
- Maximum**  
 10K GD & HD - 34.40" (17.2 per side)
- Note: Minimums are based on manufacturing tolerances only. Some tire and wheel combinations may create interference.

### FULL LOAD DIMENSIONS

Dimensions are for high profile, top mount only. Side mount is .31" higher.

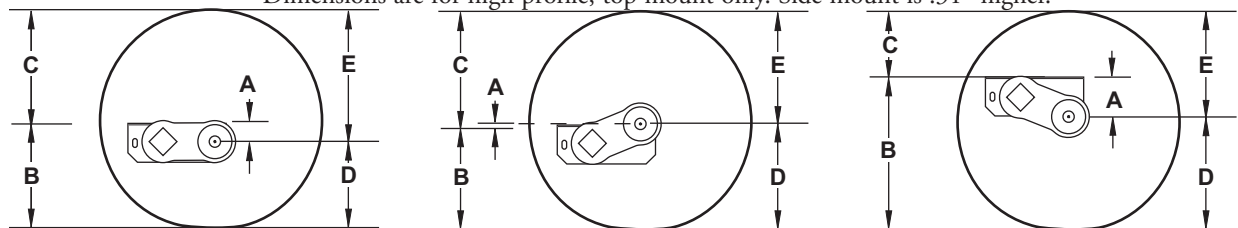

0°, 10° down

10°, 22.5° up

22.5°, 45° down

A = Center Line of spindle to top of bracket, B = Top of bracket to ground, C = Top of bracket to top of tire, D = Center Line of spindle to ground, E = Center Line of spindle to top of tire.

### START ANGLE

Tire	0°			10° Up			22.5° Up			45° Down			22.5° Down			10° Down			(All Angles)	
	A	B	C	A	B	C	A	B	C	A	B	C	A	B	C	A	B	C	D	E
10R15TR	.9	17.8	17.3	.2	16.7	18.4	1.3	15.6	18.2	5.2	22.1	13.0	3.0	19.9	15.2	1.7	18.6	16.5	16.9	18.2
11R17.5HC	.9	17.8	17.3	.2	16.7	18.4	1.3	15.6	18.2	5.2	22.1	13.0	3.0	19.9	15.2	1.7	18.6	16.5	16.9	18.2
215/75R17.5	.6	14.7	14.5	.3	13.8	15.4	1.3	12.8	16.4	5.2	19.3	9.9	2.9	17.0	12.2	1.6	15.7	13.5	14.1	15.1

### ARTICULATION DIMENSIONS

ALLOW 3" BUMP CLEARANCE FROM FULL LOAD.

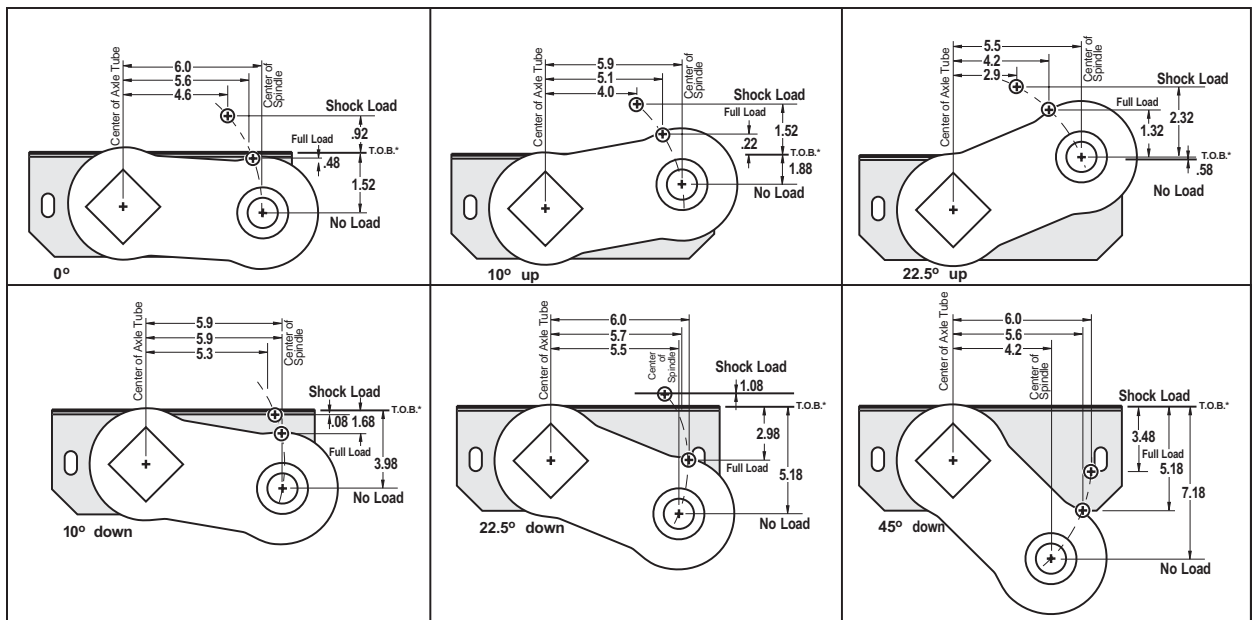

\*TOP OF BRACKET

## "How to read Torflex Articulation Dimensions"

Note: Dimensions shown here are for example only. Refer to specific Torflex Axle Page for correct dimensions.

### A) How high do I set the fenders?

Look at the 0° drawing: The 2.2 is distance from center of spindle to top of bracket.

The .1 is how far arm moves above bracket for 'Full Load'.

- 2.2 To top bracket
- + .1 From top bracket to 'Full Load'
- 2.3 Travel from 'No Load' to 'Full Load'

Fenders should be located 5.7" above tires when 'No Load' (2.3" + 3.00 DEX REQ).



### B) What is 'Shock Load'?

'Shock Load' 1.6 is how far arm travels above the top of bracket. The distance the arm moves from 'Full Load' to 'Shock Load' is the difference of 1.5.

- 1.6 Distance arm moves from 'Full Load' to 'Shock Load'
- .1 Full Load Dimension
- 1.5 Travel from 'Full Load' to 'Shock Load'

### C) What do the + marks on the curved broken line represent?

This line tells us how far forward the tire moves at each of the load points.

Using the 0° drawing again: Notice the 6.0 distance from center of spindle to center of inner bar. When the arm travels up to 'Full Load', the tire is moved forward .4". At 'Shock Load', the tire has moved forward 1.4".

### D) When trailing arm starts at 22.5° or 45° down, the calculations are subtractions rather than addition.

Look at 22.5° down drawing.

'No Load' is 4.5 from top of bracket

4.5 'Full Load' is 2.3 from top of bracket

- 2.3

2.2 Travel from "No Load" to "Full Load"

'Shock Load' is .4 above top of bracket, so the travel from 'Full Load' 2.3 to 'Shock Load' .4 is 2.7".

## ARTICULATION DIMENSIONS

UMP CLEARANCE FROM FULL LOAD.

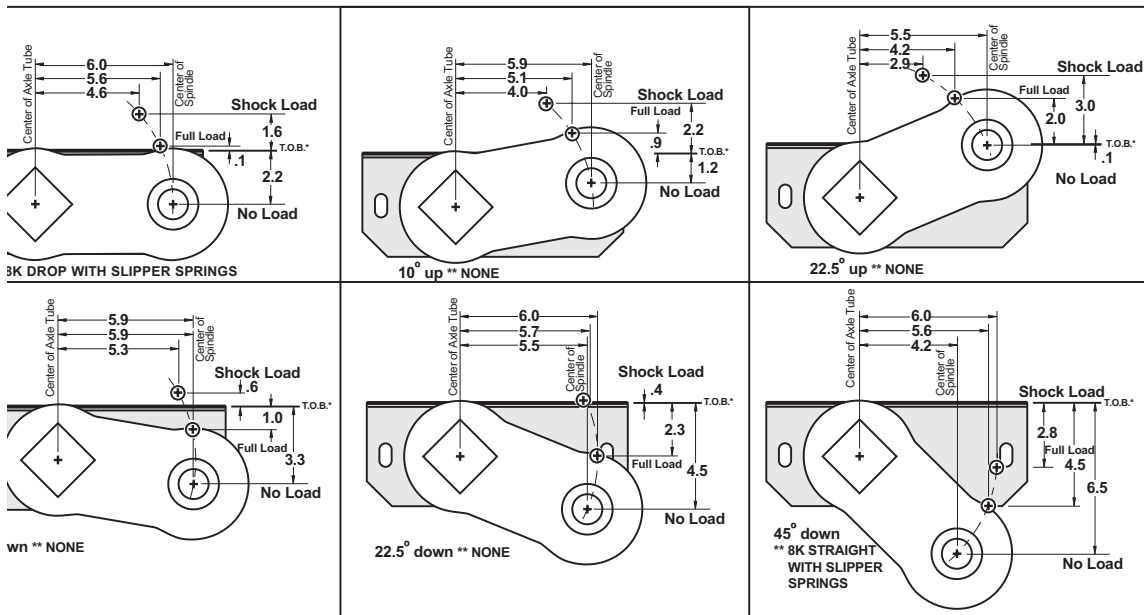

BRACKET  
:S RIDE HEIGHT EQUAL TO TUBULAR SPRUNG AXLES.



## Axle Components

Tubular Axle Beams . . . . .	B-2	10 Bolt, 8.75 Bolt Circle (Dual Wheel) . . . . .	B-32
Brake Mounting Bolts . . . . .	B-3	Nev-R-Lube Hub and Drums . . . . .	B-33 - B-34
Brake Mounting Flanges . . . . .	B-3	Redline Replacement Hub Assemblies . . . . .	B-35
Torflex Axle Beam . . . . .	B-3	Redline Wheel Bearing Kits . . . . .	B-35
Axle Spring Seats . . . . .	B-3	Redline Grease Seals . . . . .	B-35
Replacement Spindle Nuts . . . . .	B-4	Running Gear Replacement Parts . . . . .	B-36
Replacement Spindle Washers . . . . .	B-4	Packaged Spindle Nut Kits . . . . .	B-37
Brake Mounting Nuts and Lockwashers . . . . .	B-4	Packaged Wheel Studs . . . . .	B-37
Spindles . . . . .	B-5	Packaged Wheel Bolts . . . . .	B-37
Agricultural Hubs . . . . .	B-6	Packaged Rim Clamps and Wheel Nuts . . . . .	B-37
5 Bolt, 5.5" Bolt Circle . . . . .	B-6	Bearing Protectors . . . . .	B-38
4 Bolt, 5" Bolt Circle . . . . .	B-6	Replacement Bearings . . . . .	B-38
6 Bolt, 6" Bolt Circle . . . . .	B-7-B8	Bolt-On Oil Caps . . . . .	B-39
8 Bolt, 8" Bolt Circle . . . . .	B-9	Grease Caps . . . . .	B-39
Agricultural Spindles . . . . .	B-9	Replacement Races . . . . .	B-39
4 Bolt, 4" Bolt Circle . . . . .	B-12	Grease Seals, Oil Seals and Wear Sleeves . . . . .	B-40
5 Bolt, 4.5" Bolt Circle . . . . .	B-13	Complete Screw-On Oil Cap Kits . . . . .	B-40
5 Bolt, 4.5", 4.75", 5" & 5.5" Bolt Circle . . . . .	B-14	Replacement Wheel Nuts . . . . .	B-41
6 Bolt, 5.5" Bolt Circle . . . . .	B-14	Rim Clamps and Spacers . . . . .	B-41
6 Bolt, 5.5" Bolt Circle . . . . .	B-15 - B-16	Grease and Oil Cap Replacement Parts . . . . .	B-41
8 Bolt, 6.5" Bolt Circle . . . . .	B-16 - B-17	Wheel Bolts . . . . .	B-42
4 Bolt, 4" Bolt Circle . . . . .	B-18	Wheel Studs . . . . .	B-42
Replacement Hub and Drum Assemblies . . . . .	B-18		
4 Bolt, 9.4" Bolt Circle . . . . .	B-19		
5 Bolt, 4.5" Bolt Circle . . . . .	B-20		
6 Bolt, 5.5" Bolt Circle . . . . .	B-21		
5 Bolt, 4.5", 4.75", 5", 5.5" Bolt Circle . . . . .	B-21		
6 Bolt, 5.5" Bolt Circle . . . . .	B-22		
8 Bolt, 6.5" Bolt Circle . . . . .	B-23		
5 Spoke, Utility Type (Grease & Oil) . . . . .	B-23		
8 Bolt, 6.5" Bolt Circle . . . . .	B-24 - B-31		

### Informational Pages:

Equation to Figure Hub Face	
from Flange to Flange Dimension . . . . .	B-2
How To Order a Replacement Axle Beam . . . . .	B-2
Hub to Spindle Reference Chart . . . . .	B-5
How to Order Replacement	
Hubs or Hub and Drums . . . . .	B-11

## How To Order a Replacement Axle Beam

Answers to the following questions will provide us with all of the necessary information to get your axle beam ordered and in your hands quickly. Make sure you have the answers to these questions close at hand when placing your order.

- 1) Spindles: Are they straight, drop or E-Z Lube?
- 2) Inner and Outer Bearings: What are the bearing numbers?
- 3) Seal: What is the I.D. and O.D. or Reference Number of the seal?
- 4) Tube: What is the outside diameter? Is the tube solid bar or tubular?
- 5) Hub Face: What is the measurement from center to center of spindles?
- 6) Spring Pads: What is the measurement from center to center of pads?
- 7) Brake Flange: What is the measurement from outside to outside of brake flanges?



## Tubular Axle Beams

Straight Spindle			4" Drop Spindle	
Part No.	Ref. No.	Description	Part No.	Ref. No.
T20BTR	169000	2,000 lb, 1 3/4" Round	N/A	N/A
T20BTR-EZ	169050	2,000 lb, 1 3/4" Round, w/ E-Z Lube	N/A	N/A
N/A	N/A	2,000 lb, 2 3/8" Round	TD20BTR	170400
N/A	N/A	2,000 lb, 2 3/8" Round w/ E-Z Lube	TD20BTR-EZ	170450
T3584F	169200	3,500 lb, 2 3/8" Round	TD3584F	170600
T3584F-EZ	169250	3,500 lb, 2 3/8" Round w/ E-Z Lube	TD3584F-EZ	170650
N/A	N/A	3,500 lb, 6" Drop, 2 3/8" Round	TD63584F	170800
N/A	N/A	3,500 lb, 6" Drop, 2 3/8" Round w/ E-Z Lube	TD63584F-EZ	170850
T60R42F	169410	6,000 lb, Regular Duty, 3" Round	TD60R42F	171010
T60R42F-EZ	169460	6,000 lb, Regular Duty, 3" Round, w/ E-Z Lube	TD60R42F-EZ	171050
T6042F	169600	6,000 lb, 3" Round	TD6042F	171200
T6042F-EZ	169650	6,000 lb, 3" Round, w/ E-Z Lube	TD6042F-EZ	171250
T70DX	169800	7,000 lb, 3" Round	TD70DX	171400
T70DX-EZ	169850	7,000 lb, 3" Round, w/ E-Z Lube	TD70DX-EZ	171450
T72DX	169900	7,200 lb, 3" Round	TD72DX	171500
T72DX-EZ	169950	7,200 lb, 3" Round, w/ E-Z Lube	TD72DX-EZ	171550
T80DX	170000	8,000 lb, 3 1/2" Round	TD80DX	171600
T80DX-EZ	170100	8,000 lb, 3 1/2" Round, w/ E-Z Lube	TD80DX-EZ	171605
T90DX7	170225	9,000 lb, 4" Round, 7 Bolt Flange	N/A	N/A
T10GD-DX7	170250	10,000 lb, General Duty, 5" Round, 7 Bolt Flange	N/A	N/A
T10HD-DX7	170275	10,000 lb, Heavy Duty, 5" Round, 7 Bolt Flange	N/A	N/A
T10HD-AIR	170300	10,000 lb, Heavy Duty, 5" Round, w/ Air Brake Spider	N/A	N/A

## Equation to Figure Hub Face from Flange to Flange Dimension

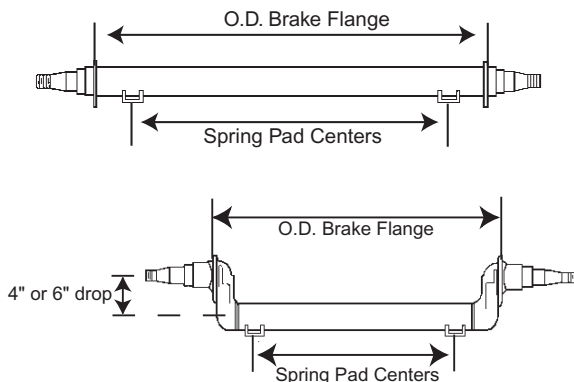

This chart is a handy guide for figuring the hub face dimensions, when you only have a bare beam with a flange from which to measure.

Axle Model	Equation
2K	Hub Face = Outside of flanges + 6.90
3.5K	Hub Face = Outside of flanges + 6.34
5.2LK (655)	Hub Face = Outside of flanges + 8.73
6K, 7K (865)	Hub Face = Outside of flanges + 8.73
5.2K - 6K w/ Demountable Hub	Track = Outside of flanges + 7.73
7.2K	Hub Face = Outside of flanges + 7.54
8K	Hub Face = Outside of flanges + 9.09
Old 9K	Hub Face = Outside of flanges + 10.46
9K, 10K General Duty	Hub Face = Outside of flanges + 13.50
10K Heavy Duty	Hub Face = Outside of flanges + 14.35
12K Low Profile	Hub Face = Outside of flanges + 21.77
12K High Profile	Hub Face = Outside of flanges + 15.27
15K	Hub Face = Outside of flanges + 17.45
10 on 11 1/4" Hub	Hub Face = Outside of flanges + 11.16
Tag Axle w/9-20 Drum	Hub Face = Outside of flanges + 17.19
Tag Axle w/9-32 Drum	Hub Face = Outside of flanges + 15.38

Note: These equations are valid for any axle where the same hub is used. That is to say, for example, any hub that goes on a 3,500 lb. axle has a total flange to hub face difference of 6.34" regardless of whether it is a straight, drop or torflex

## Torflex Axle Beam

Std Grease			E-Z Lube	
Part No.	Ref. No.	Description	Part No.	Ref. No.
9TF20B	171620	#9 Torflex Beam, 2000 lb. Cap, no flange	9TF20B-EZ	171625
10TF35B	171630	#10 Torflex Beam, 3500 lb. Cap, w/ flange	10TF35B-EZ	171635
11TF60B	171640	#11 Torflex Beam, 6000 lb. Cap, w/ flange	11TF60B-EZ	171645
12TF70B	171650	#12 Torflex Beam, 7000 lb. Cap, w/ flange	12TF70B-EZ	171655
12VTF72B	171657	#12V Torflex Beam, 7200 lb. Cap, w/ flange	12VTF72B-EZ	171658
13TF80B	171660	#13 Torflex Beam, 8000 lb. Cap, w/ flange	13TF-80B-EZ	171670

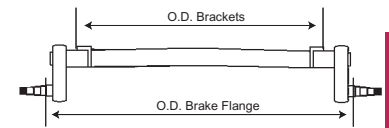

AXLE  
COMPONENTS

## Axle Spring Seats

Part No.	Ref. No.	Use With:
3-49	172600	1 3/4" Round Axle
3-43	172800	2 3/8" Round Axle
3-42	173000	3" Round Axle
3-48	173200	3 1/2" Round Axle
3-51	173400	4" Round Axle
3-72	173600	5" Round 10,000 lb Axles with 2 1/2" Wide Springs
3-66	173800	5" Round Axles w/ 3" Wide Springs



## Brake Mounting Flanges

Part No.	Ref. No.	Use With:	Brake Size	Hole I.D.
4-34	189200	1 3/4" Round Axle	7", 4 bolt	1.64"
4-35	189400	2 3/8" Round Axle	10", 4 bolt	2.27"
4-44-1	189600	3" Round Axle	12", 5 bolt	2.75"
721668	189800	2" Round Axle	10", 4 bolt	2.06"
721671	190000	2 1/4" Round, 2" Square Axles	12", 5 bolt	2.30"
4-50	190200	3 1/2" Round Axles	12 1/4" 8K, 4 bolt	3.01"
4-43-1	190600	5" Round Axles	10K, 12K, 15K, 6 bolt	4.08"
4-48	190800	5" Round Axles	10K, 12K, 15K, 7 bolt	4.17"



## Brake Mounting Bolts

Part No.	Ref. No.	Use With:	Brake Size	Hole I.D.
7-225	190950	12" x 2" Brakes (#11 & #12 Torflex)	3/8"-16 Self-tapping	3/4"
7-5	191000	12" x 2" Brakes	3/8"-24	1 1/4"
7-75	191700	10" Brakes	7/16"-20	1 1/4"
7-116	192200	10K, 12K, 15K Brakes	7/16"-20	1 3/4"
7-97	192800	8K, 9K Brakes	1/2"-20	1 1/2"



## Brake Mounting Nuts and Lockwashers



Part No.	Ref No.	Description	I.D.	Use With:
38N	077600	Nut	3/8"-20	12" Brakes
38LW	077800	Lockwasher	3/8"	12" Brakes
6-17	191800	Nut	7/16"-20	10" Brakes
5-8	192000	Lockwasher	7/16"	10" Brakes
6-92	192600	Locknut	7/16"-20	10K, 12K, 15K Brakes
6-46	193000	Locknut	1/2"-20	8K, 9K Brakes

## Replacement Spindle Washers



Plain Washer



D Washer



Tang type "A"  
Washer



Tang type "B"  
Washer



Tongue Washer

Part No.	Ref. No.	I.D.	Type
165863	166400	1"	Tongue Type for Replacement Spindles
5-70	166600	1 1/2"	Tongue Type for 9K & 10K GD
5-98	166800	2 5/8"	Tongue Type for 20K & 22.5K
5-99	167000	2 5/8"	Tang Type B for 20K & 22.5K
SW1000	167200	1"	Plain Type for Replacement Spindles
5-23	167400	1"	"D" Type for 3500 lb. & 6K Reg Duty
5-101	167600	1"	Tang Type A for E-Z Lube 2K to 8K
5-57	167800	1"	"D" Type 6K, 7K, 8K, (& 9K prior to 10/89)
5-147-1	167825	1"	42mm Nev-R-Lube, .25 x 2.25
5-149	167830	1"	50mm Nev-R-Lube, .31 x 2.50
5-150	167835	1"	35mm Nev-R-Lube, .25 x 1.88
165950	168000	1 1/2"	"D" Type, Inner Washer for 99 Spindle
165963	168200	1 1/2"	"D" Type, Outer Washer for 99 Spindle
5-71	168400	1 1/2"	Tang Type B for 9K & 10K GD
5-59	168600	1 3/4"	Tang Type B for 10K, 12K, & 15K
5-60	168800	1 3/4"	Tongue Type for 10K, 12K & 15K

## Replacement Spindle Nuts

Part No.	Ref. No.	Diameter	Description
165931	164600	7/8"-14	Fine Thread, Castle Nut
165686	164800	1"-14	Fine Thread, Castle Nut 2K thru 9K (9K prior to 10/89)
6-183	164900	1"-14	Self-locking for Nev-R-Lube
6-96	165200	1 1/2"-12	Fine Thread, Nut for 9K & 10K GD
6-84	165400	1 3/4"-12	Fine Thread, Nut for 10K, 12K & 15K
90623	165600	1 1/2"-12	Fine Thread, Castle Nut for #99 Spindle
6-114	165800	2 5/8"-16	Fine Thread, Inner Nut for 20K-25K
6-115	166000	2 5/8"-16	Fine Thread, Outer Nut for 20K-25K



## Spindles

Spindles come complete with spindle nut, washer and cotter key (tang washer supplied with E-Z Lube spindles). Note: Spindle dimensions shown are for identification purposes only and do not reflect min-max tolerances required for production of spindles.

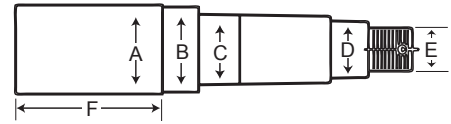

Part No.	Ref No.	Capacity	A	B	C	D	E	F	Description
R104BT8	163200	1000 lb	1.25	1.24	.99	.99	1.00	4.00	BT8
R104BTREZ	163325	1000 lb	1.25	1.50	1.06	1.06	1.00	4.00	BTR E-Z Lube
R104BT8-38	163400	1000 lb	1.38	1.24	.99	.99	1.00	4.00	BT8
R20484	163600	1750 lb	1.75	1.73	1.38	1.06	1.00	4.00	#84
R20384EZ	163725	1750 lb	1.75	1.73	1.38	1.06	1.00	3.00	#84 E-Z Lube & Flge
R2061/284	163800	1750 lb	1.75	1.73	1.38	1.06	1.00	6.50	#84
R50642	164000	2500 lb	2.25	2.24	1.74	1.25	1.00	6.00	#42
R50342EZ	164125	2600 lb	2.25	2.24	1.74	1.25	1.00	3.00	#42 E-Z Lube & Flge
SP204BT8	164200	1000 lb	1.50	1.24	.99	.99	1.00	4.00	BT8, 1.5" Square
SP20484	164400	1750 lb	1.5	1.24	.99	.99	1.00	4.00	#84, 1.5" Square

## Hub to Spindle Reference Chart

Use the following chart when matching hubs to spindles. Choose capacity, bolt pattern and desired shank size.  
Chart Lists spindle part number first, hub part number second.

1,000 lb. Capacity				
Bolt Pattern	1 1/4" Round, 4" Long	1 3/8" Round, 4" Long	1 1/2" Square, 4" long	1 1/4" Round, 4" Long E-Z
Spindle Part No.	R104BT8	R104BT8-38	SP204BT8	R104BTREZ
Hub Part No.	4 on 4"	34822UC1	34822UC1	8-91-05UC1-EZ
Spindle Part No.	R104BT8	R104BT8-38	SP204BT8	R104BTREZ
Hub Part No.	5 on 4 1/2"	34822545UC1	34822545UC1	8-259-5UC1-EZ

1,750 lb. Capacity				
Bolt Pattern	1 3/4" Round, 4" Long	1 3/4" Round, 6 1/2" Long	1 1/2" Square, 4" Long	1 3/4" Round, 3" Long E-Z Lube
Spindle Part No.	R20484	R2061/284	SP20484	R20384EZ
Hub Part No.	5 on 4 1/2"	84545UC1	84545UC1	84545UC1-EZ
Spindle Part No.	R20484	R2061/284	SP20484	R20384EZ
Hub Part No.	5 on 4 3/4"	84545UC1	845475UC1	845475UC1-EZ
Spindle Part No.	R20484	R2061/284	SP20484	R20384EZ
Hub Part No.	5 on 5"	84545UC1	84550UC1	84550UC1-EZ
Spindle Part No.	R20484	R2061/284	SP20484	R20484EZ
Hub Part No.	5 on 5 1/2"	84545UC1	84555UC1	84555UC1-EZ
Spindle Part No.	R20484	R2061/284	SP20484	R20384EZ
Hub Part No.	6 on 5 1/2"	84545UC1	84655UC1	84655UC1-EZ

2,500 lb Cap.		2,600 lb. Cap.	
Bolt Pattern	2 1/4" Round x 6" Long 2,500 lb	2 1/4" Round x 3" Long E-Z Lube	
Spindle Part No.	R50642	R50342EZ	
Hub Part No.	6 on 5 1/2"	42655UC1	8-213-5UC1-EZ
Spindle Part No.	R50642	R50342EZ	
Hub Part No.	8 on 6 1/2"	42865UC1	8-231-9UC1-EZ

## Agricultural Hubs

We have Agricultural Hubs and Spindles in the most popular bolt patterns for use in building or repairing implement wagons, carts or machinery. Agricultural hubs and spindles are designed for low-speed applications; weight capacities shown for speeds not to exceed 20 m.p.h.

### 4 Bolt, 5" Bolt Circle

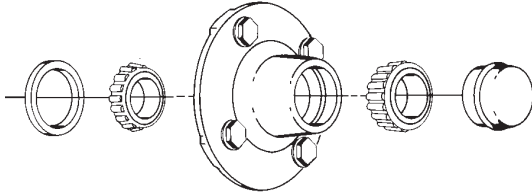

- LM67048 Inner, LM11949 Outer Bearing
- Capacity of 1,500 lbs. per each
- Use with spindle #AS1500E

Part No.	Ref. No.	Description
AH15450ECOMP	125600	Complete Hub Assembly - Includes the following
AH15450E	125400	Agricultural Hub Only, Drilled and Tapped
LM67048	130000	Inner Bearing
LM11949	133200	Outer Bearing
LM67010	135400	Inner Race
LM11910	139000	Outer Race
SL150	160400	Grease Seal (2.332" O.D., 1.50" I.D.)
1527	151000	Grease Cap, 1.957" O.D., Drive-in
LB509	143300	Wheel Bolt, 1/2" Diameter

### 5 Bolt, 5.5" Bolt Circle

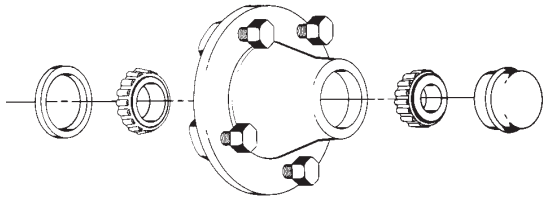

- LM48548 Inner, LM67048 Outer Bearing
- Capacity of 2,500 lbs. per each
- Use with spindle #AS2500F

Part No.	Ref. No.	Description
AH25555FCOMP	126000	Complete Hub Assembly - Includes the following
AH25555F	125800	Agricultural Hub Only, Drilled and Tapped
LM48548	129800	Inner Bearing
LM67048	130000	Outer Bearing
LM48510	135200	Inner Race
LM67010	135400	Outer Race
SL175	160600	Grease Seal (2.722" O.D., 1.75" I.D.)
45896	151600	Grease Cap, 2.44" O.D., Drive-in
LB509	143300	Wheel Bolt, 1/2" Diameter



## 6 Bolt, 6" Bolt Circle

- 29749 Inner, LM67048 Outer Bearing
- Capacity of 3,000 lbs. per each
- Use with spindle #AS3000E

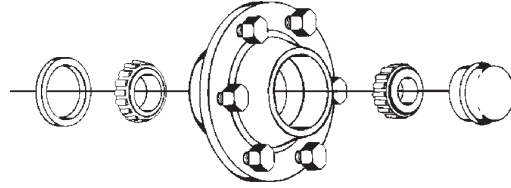

Part No.	Ref. No.	Description
AH30660FCOMP	126400	Complete Hub Assembly - Includes the following
AH30660F	126200	Agricultural Hub Only, Drilled and Tapped
29749	133600	Inner Bearing
LM67048	130000	Outer Bearing
29710	139200	Inner Race
LM67010	135400	Outer Race
SL175	160600	Grease Seal (2.722" O.D., 1.75" I.D.)
45896	151600	Grease Cap, 2.44" O.D., Drive-in
LB509	143300	Wheel Bolt, 1/2" Diameter

## 6 Bolt, 6" Bolt Circle

- 501349 Inner, LM67048 Outer Bearing
- Capacity of 3,500 lbs. per each
- Use with spindle #AS3500F

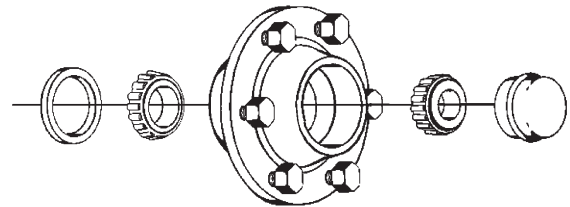

Part No.	Ref. No.	Description
AH35660FCOMP	126800	Complete Hub Assembly - Includes the following
AH35660F	126600	Agricultural Hub Only, Drilled and Tapped
501349	133800	Inner Bearing
LM67048	130000	Outer Bearing
501310	139400	Inner Race
LM67010	135400	Outer Race
SL200	160800	Grease Seal (3.066" O.D., 2.00" I.D.)
45896	151600	Grease Cap, 2.44" O.D., Drive-in
LB569	143400	Wheel Bolt, 9/16" Diameter

### 6 Bolt, 6" Bolt Circle

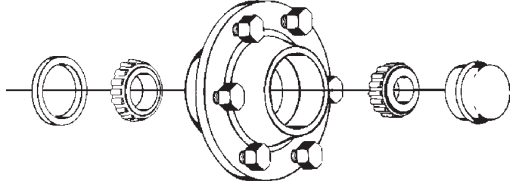

- 25580 Inner, LM67048 Outer Bearing
- Capacity of 3,000 lbs. per each
- Use with #42 spindles
- For spindles requiring 2 1/4" I.D. grease seal

Part No.	Ref. No.	Description
42660UC1	126150	Complete Hub Assembly - Includes the following
8-213-8	126100	Agricultural Hub Only, Drilled and Tapped
25580	130800	Inner Bearing
LM67048	130000	Outer Bearing
25520	136200	Inner Race
LM67010	135400	Outer Race
42385	159600	Grease Seal (3.376" O.D., 2.250" I.D.)
45896	151600	Grease Cap, 2.44" O.D., Drive-in
LB569	143400	Wheel Bolt, 9/16" Diameter



### 6 Bolt, 6" Bolt Circle

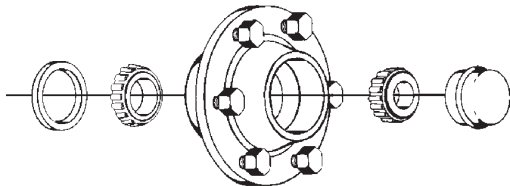

- 25580 Inner, LM67048 Outer Bearing
- Capacity of 3,000 lbs. per each
- Fits Dexter 5,200 lbs. thru 7,000 lb. axles
- For Spindles requiring 2 1/8" I.D. Grease Seal

Part No.	Ref. No.	Description
8-213-8UC1	126125	Complete Hub Assembly - Includes the following
8-213-8	126100	Agricultural Hub Only, Drilled and Tapped
25580	130800	Inner Bearing
LM67048	130000	Outer Bearing
25520	136200	Inner Race
LM67010	135400	Outer Race
10-1	159800	Grease Seal (3.376" O.D., 2.125" I.D.)
45896	151600	Grease Cap, 2.44" O.D., Drive-in
LB569	143400	Wheel Bolt, 9/16" Diameter



Agricultural Spindles Shown on Page B-9

## 8 Bolt, 8" Bolt Circle

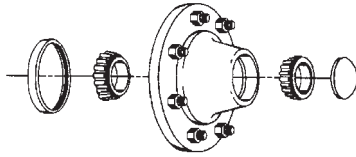

- 603049 Inner, LM67048 Outer Bearing
- Capacity of 4,500 lbs. per each
- Use with spindle #AS4500F

Part No.	Ref. No.	Description
AH45880FCOMP	127200	Complete Hub Assembly - Includes the following
AH45880F	127000	Agricultural Hub Only, Drilled and Tapped
603049	134200	Inner Bearing
LM67048	130000	Outer Bearing
603011	139800	Inner Race
LM67010	135400	Outer Race
SL226	161000	Grease Seal (3.066" O.D., 2.250" I.D.)
45896	151600	Grease Cap, 2.44" O.D., Drive-in
LB569	143400	Wheel Bolt, 9/16" Diameter

## 8 Bolt, 8" Bolt Circle

- 501349 Outer, 506849 Inner Bearing
- Capacity of 6,000 lbs. per each
- Use with spindle #AS6000F

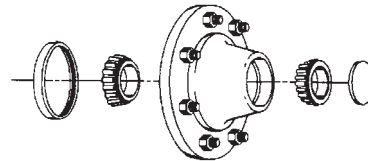

Part No.	Ref. No.	Description
AH60880FCOMP	127400	Complete Hub Assembly - Includes the following
AH60880F	127300	Agricultural Hub Only, Drilled and Tapped
506849	134000	Inner Bearing
501349	133800	Outer Bearing
506810	139600	Inner Race
501310	139400	Outer Race
SL275	161200	Grease Seal (3.756" O.D., 2.75" I.D.)
1609	152600	Grease Cap, 3.125" O.D., Drive-in
6-109	141000	5/8" Hex Wheel Nut RH

## Agricultural Spindles

Each spindle comes complete with nuts and washers when applicable.

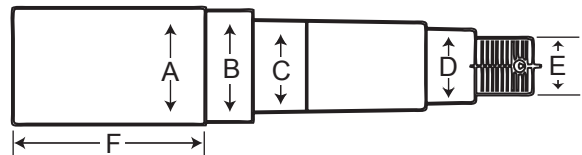

Part No.	Ref. No.	Capacity	A	B	C	D	E	F
AS1500E	127600	1500 lb.	1.62	1.50	1.25	.75	3/4-16 UNF	5 3/8
AS2500F	127800	2500 lb.	1.75	1.75	1.37	1.25	3/4-16 UNF	8
AS3000F	128000	3000 lb.	1.75	1.75	1.50	1.25	3/4-16 UNF	5
AS3500F	128200	3500 lb.	2.00	2.00	1.63	1.25	3/4-16 UNF	5 1/2
AS4500F	128400	4500 lb.	2.25	2.25	1.78	1.25	3/4-16 UNF	8 1/4
AS6000F	128600	6000 lb.	2.75	2.75	2.16	1.63	1-14 UNF	8 1/4

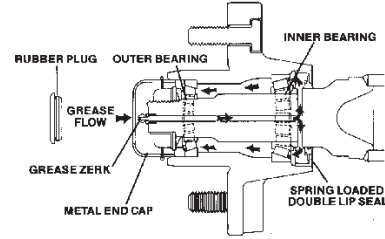
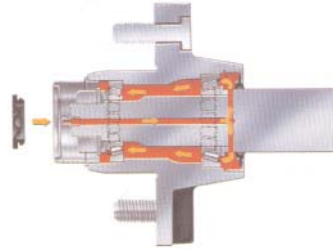

### E-Z Lube End Units

For custom building axles, or anywhere a spindle/hub would be preferred over a complete axle. Examples would include: portable welders, cattle "squeeze-chutes", industrial dollies, etc. These End Units come completely assembled and feature the E-Z Lube option for easier bearing lubrication. Available with idler hubs and with electric or hydraulic brakes.

Part No.	Ref. No.	Cap. Per Pair	Bolt Pattern	Hub Type	Shank Size
20440IEU	105050	2000	4 on 4"	Idler	1 1/4" x 4"
20545IEU	105055	2000	5 on 4 1/2"	Idler	1 1/4" x 4"
35545IEU	105060	3500	5 on 4 1/2"	Idler	1 3/4" x 3"
35545EEULH	105065	3500	5 on 4 1/2"	LH Electric	1 3/4" x 3"
35545EEURH	105070	3500	5 on 4 1/2"	RH Electric	1 3/4" x 3"
35545HEULH	105075	3500	5 on 4 1/2"	LH Uni Servo	1 3/4" x 3"
35545HEURH	105080	3500	5 on 4 1/2"	RH Uni Servo	1 3/4" x 3"
52655IEU	105085	5200	6 on 5 1/2"	Idler	2 1/4" x 3"
52655EEULH	105095	5200	6 on 5 1/2"	LH Electric	2 1/4" x 3"
52655EEURH	105100	5200	6 on 5 1/2"	RH Electric	2 1/4" x 3"
52655HEULH	105102	5200	6 on 5 1/2"	LH Uni Servo	2 1/4" x 3"
52655HEURH	105104	5200	6 on 5 1/2"	RH Uni Servo	2 1/4" x 3"
52655HYEULH	105106	5200	6 on 5 1/2"	LH Duo Servo	2 1/4" x 3"
52655HYEURH	105108	5200	6 on 5 1/2"	RH Duo Servo	2 1/4" x 3"
52865IEU	105110	5200	8 on 6 1/2"	Idler	2 1/4" x 3"
52865EEULH	105112	5200	8 on 6 1/2"	LH Electric	2 1/4" x 3"
52865EEURH	105114	5200	8 on 6 1/2"	RH Electric	2 1/4" x 3"
52865HEULH	105125	5200	8 on 6 1/2"	LH Uni Servo	2 1/4" x 3"
52865HEURH	105130	5200	8 on 6 1/2"	RH Uni Servo	2 1/4" x 3"
52865HYEULH	105145	5200	8 on 6 1/2"	LH Duo Servo	2 1/4" x 3"
52865HYEURH	105150	5200	8 on 6 1/2"	RH Duo Servo	2 1/4" x 3"

## How to Order Replacement Hubs or Hub and Drums

To order the correct replacement hub or hub and drum, the following steps can be used to simplify the ordering process:

1. **Determine the Bolt Pattern of the Hub.**  
Refer to page E-5 of this catalog for instructions on making this determination.
2. **Determine the Inner and Outer Bearing Numbers.** Note whether the bearings use grease or oil bath lubrication.
3. Measure the old hub seal to insure that the I.D. and O.D. dimensions will be the same.
4. Verify the Stud Diameter.
5. If the axle is a brake axle, measure the diameter and width of the brake to determine brake size.
6. Look for any casting numbers on front or rear of hub or hub and drum.
7. On heavier axles, such as the Dexter 8,000 lb. or 9,000 lb. axles, you need to determine the hub pilot diameter. This can be accomplished by measuring the center hole of your wheel.
8. On 8,000 lb and larger axles determine if it is equipped with ABS, and requires a drum / rotor with ABS exciter ring installed.

Once you have the above information, you are ready to locate your replacement hub or hub and drum.

Hubs are listed on pages B-12 thru B-17. Hub and drums are listed on pages B-18 thru B-32.

Locate the bolt pattern desired, then find the table that lists our inner and outer bearing numbers.

Verify:

- Inner/Outer Bearing Numbers
- Type of Bearing Lubrication
- Stud Size
- Seal Size
- Drum Size

Confirm brake size and/or hub pilot diameter (if applicable). Complete assemblies contain the hub or hub and drum, inner and outer bearings, seal, grease cap or oil cap and all necessary wheel nuts.



Replacement Hubs are listed in order of bolt pattern, starting with 4-bolt, and ending with 8-bolt.  
All are cast iron, one-piece units for durability.

### 4 Bolt, 4" Bolt Circle

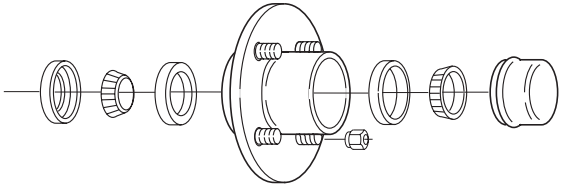

- Fits BT8 1" Spindle, L44643 inner/outer bearings
- Capacity of 1,250 lbs. per each

Part No.	Ref No.	Description
34822UC1	105400	Complete Hub Assembly - Includes the following:
34822	105200	Hub Only
L44643	128800	Inner / Outer Bearing
L44610	134400	Inner / Outer Race
34823	157800	Grease Seal (1.983" O.D., 1.249" I.D.)
46749	151200	Grease Cap, 1.986" O.D., Drive-in
25-53	147800	Screw in stud, 1/2" Diameter
X1023R	140600	1/2" Cone Wheel Nut

### 4 Bolt, 4" Bolt Circle

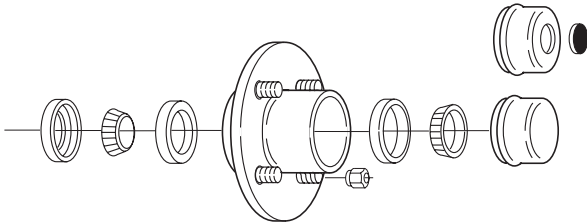

- Fits Dexter 2,000 lb. axle, BTR 1 1/16" spindle, L44649 inner / outer bearings
- Available in Standard or E-Z Lube application

Part No.	Ref. No.	Description
8-91-05UC1	105800	Complete Hub Assembly
8-91-05UC1-EZ	105825	Complete E-Z Lube Hub Assembly
8-91-05	105600	Hub Only
L44649	129000	Inner / Outer Bearing
L44610	134400	Inner / Outer Race
10-9	158000	Grease Seal (1.987" O.D., 1.5" I.D.)
10-60	158200	Grease Seal (1.987" O.D., 1.5" I.D.), for E-Z Lube
46749	151200	Grease Cap, 1.986" O.D., Drive-in
21-3-1	151400	Grease Cap, 1.986" O.D., Drive-in, for E-Z Lube
85-1	155400	Grease Cap Plug for E-Z Lube
25-53	147800	Screw in Stud, 1/2" Diameter
X1023R	140600	1/2" Cone Wheel Nut



## 5 Bolt, 4.5" Bolt Circle

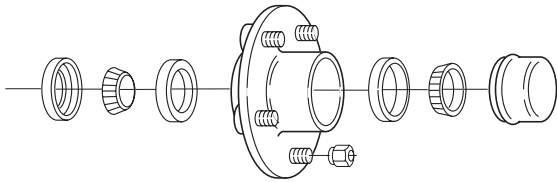

- Fits BT8 1" Spindle, L44643 inner/outer bearings
- Capacity of 1,250 lbs. per each
- 5 1/2" diameter hub flange, use with 8" to 10" wheels
- 6 1/2" diameter hub flange, use with 12" to 15" wheels

Part No.	Ref No.	Description
34822545UC1	106200	Complete Hub Assembly - 5 1/2" Hub Flange
34822545	106000	Hub Only - 5 1/2" Hub Flange
8-258BTUC1	106310	Compleat Hub Assembly - 6 1/2" Hub Flange
8-258-5	106300	Hub Only - 6 1/2" Hub Flange
L44643	128800	Inner / Outer Bearing
L44610	134400	Inner / Outer Race
34823	157800	Grease Seal (1.983" O.D., 1.249" I.D.)
46749	151200	Grease Cap, 1.986" O.D., Drive-in
25-53	147800	Screw in stud, 1/2" Diameter
X1023R	140600	1/2" Cone Wheel Nut

## 5 Bolt, 4.5" Bolt Circle

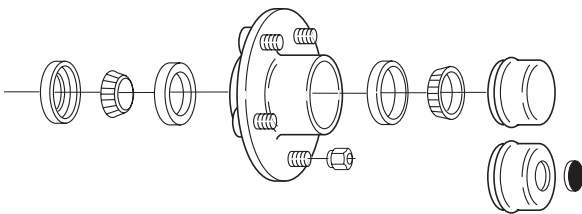

- Fits Dexter 2,000 lb. axle, BTR 1 1/16" spindle, L44649 inner / outer bearings
- Available in Standard or E-Z Lube application
- 5 1/2" diameter hub flange, use with 8" to 10" wheels
- 6 1/2" diameter hub flange, use with 12" to 15" wheels

Part No.	Ref. No.	Description
8-259-5UC1	106600	Complete Hub Assembly - 5 1/2" Hub Flange
8-259-5UC1-EZ	106625	Complete E-Z Lube Hub Assembly - 5 1/2" Hub Flange
34822545	106000	Hub Only - 5 1/2" Hub Flange
8-258-5UC1	106325	Complete Hub Assembly - 6 1/2" Hub Flange
8-258-5UC1-EZ	106330	Complete E-Z Lube Hub Assembly - 6 1/2" Hub Flange
8-258-5	106300	Hub Only - 6 1/2" Hub Flange
L44649	129000	Inner / Outer Bearing
L44610	134400	Inner / Outer Race
10-9	158000	Grease Seal (1.987" O.D., 1.5" I.D.)
10-60	158200	Grease Seal (1.987" O.D., 1.5" I.D.), for E-Z Lube
46749	151200	Grease Cap, 1.986" O.D., Drive-in
21-3-1	151400	Grease Cap, 1.986" O.D., Drive-in, for E-Z Lube
85-1	155400	Grease Cap Plug for E-Z Lube
25-53	147800	Screw in Stud, 1/2" Diameter
X1023R	140600	1/2" Cone Wheel Nut



## 5 Bolt, 4.5", 4.75", 5" & 5.5" Bolt Circle

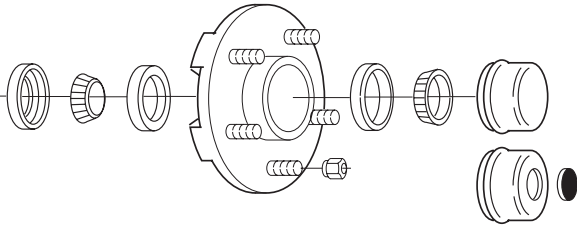

- L68149 Inner / L44649 Outer Bearings
- Capacity of 1,750 lbs. per each
- Fits #84 Spindle
- Std. Grease or E-Z Lube Application
- Used on Dexter and most 3,500 lb. Axles
- 4 Different Bolt patterns

Part No.	Ref. No.	Description
84545UC1	107000	Complete Hub Assembly - 4.5" Bolt Circle
84545UC1-EZ	107025	Complete E-Z Lube Hub Assembly - 4.5" Bolt Circle
84545	106800	Hub Only - 4.5" Bolt Circle
845475UC1	107400	Complete Hub Assembly - 4.75" Bolt Circle
845475UC1-EZ	107425	Complete E-Z Lube Hub Assembly - 4.75" Bolt Circle
845475	107200	Hub Only - 4.75" Bolt Circle
84550UC1	107800	Complete Hub Assembly - 5" Bolt Circle
84550UC1-EZ	107825	Complete E-Z Lube Hub Assembly - 5" Bolt Circle
84550	107600	Hub Only - 5" Bolt Circle
84555UC1	108200	Complete Hub Assembly - 5.5" Bolt Circle
84555UC1-EZ	108225	Complete E-Z Lube Hub Assembly - 5.5" Bolt Circle
84555	108000	Hub Only - 5.5" Bolt Circle
L68149	129200	Inner Bearing
L44649	129000	Outer Bearing
L68111	135000	Inner Race
L44610	134400	Outer Race
58846	158800	Grease Seal (2.565" O.D., 1.719" I.D.)
10-19	159000	Grease Seal (2.565" O.D., 1.719" I.D.), for E-Z Lube
46749	151200	Grease Cap, 1.986" O.D., Drive-in
21-3-1	151400	Grease Cap, 1.986" O.D., Drive-in, for E-Z Lube
85-1	155400	Grease Cap Plug for E-Z Lube
7-122	144600	Drive-in Stud, 1/2" Diameter
X1023R	140600	1/2" Cone Wheel Nut



## 6 Bolt, 5.5" Bolt Circle

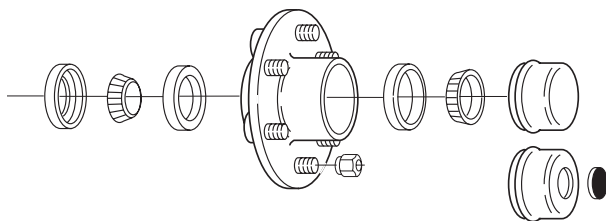

- L68149 Inner / L44649 Outer Bearing
- Capacity of 1,750 lbs. per each
- Fits #84 Spindle
- Std. Grease or E-Z Lube Application
- Used on Dexter and most 3,500 lb. axles

Part No.	Ref. No.	Description
84655UC1	108600	Complete Hub Assembly
84655UC1-EZ	108625	Complete E-Z Lube Hub Assembly
84655	108400	Hub Only



Components of this hub are the same as listed in the table above



## 6 Bolt, 5.5" Bolt Circle

- 25580 Inner / 15123 Outer Bearings
- Capacity of 3,000 lbs. per each
- Fits Dexter 5,200 lb. / 6,000 lb. axles
- For Spindles requiring 2 1/8", or 2 1/4" I.D. Grease Seal
- Std. Grease or E-Z Lube Application

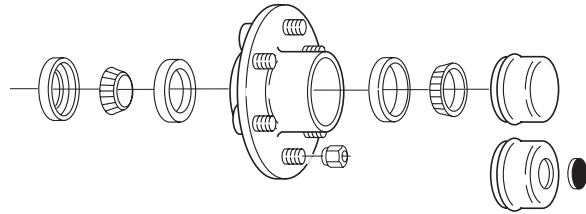

AXLE  
COMPONENTS

Part No.	Ref. No.	Description
42655UC1	109800	Complete Hub Assembly - 2 1/4" I.D. Seal
42655UC1-EZ	109810	Complete E-Z Lube Hub Assembly - 2 1/4" I.D. Seal
8-213-9UC1	109900	Complete Hub Assembly - 2 1/8" I.D. Seal
8-213-9UC1-EZ	109950	Complete E-Z Lube Hub Assembly - 2 1/8" I.D. Seal
42655	109600	Hub Only
25580	130800	Inner Bearing
15123	130400	Outer Bearing
25520	136200	Inner Race
15245	135600	Outer Race
42385	159600	Grease Seal (3.376" O.D., 2.25" I.D.)
10-1	159800	Grease Seal (3.376" O.D., 2.125" I.D.)
10-10	160000	Grease Seal (3.376" O.D., 2.125" I.D.), for E-Z Lube
45896	151600	Grease Cap, 2.44" O.D., Drive-in
21-1-1	151800	Grease Cap, 2.44" O.D., Drive-in, for E-Z Lube
85-1	155400	Grease Cap Plug for E-Z Lube
7-122	144600	Drive-in Stud, 1/2" Diameter
X1023R	140600	1/2" Cone Wheel Nut



## 6 Bolt, 5.5" Bolt Circle

- 25580 Inner / LM67048 Outer Bearings
- Capacity of 3,000 lbs. per each
- Fits Dexter 5,200 lb. and 6,000 lb. axles
- Std. Grease or E-Z Lube Application
- Spindles requiring 2 1/8" I.D. Grease Seal

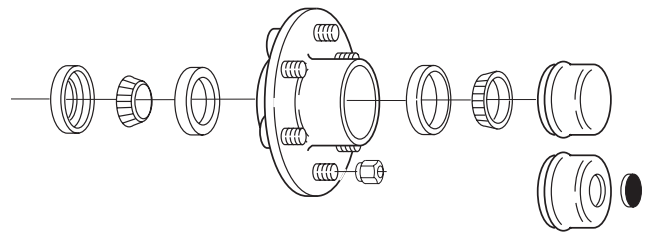

Part No.	Ref. No.	Description
8-213-5UC1	110200	Complete Hub Assembly
8-213-5UC1-EZ	110225	Complete E-Z Lube Hub Assembly
8-213-5	110000	Hub Only
25580	130800	Inner Bearing
LM67048	130000	Outer Bearing
25520	136200	Inner Race
LM67010	135400	Outer Race
42385	159600	Grease Seal (3.376" O.D., 2.25" I.D.)
10-1	159800	Grease Seal (3.376" O.D., 2.125" I.D.)
10-10	160000	Grease Seal (3.376" O.D., 2.125" I.D.), for E-Z Lube
45896	151600	Grease Cap, 2.44" O.D., Drive-in
21-1-1	151800	Grease Cap, 2.44" O.D., Drive-in, for E-Z Lube
85-1	155400	Grease Cap Plug for E-Z Lube
7-122	144600	Drive-in Stud, 1/2" Diameter
X1023R	140600	1/2" Cone Wheel Nut



## 6 Bolt, 5.5" Bolt Circle

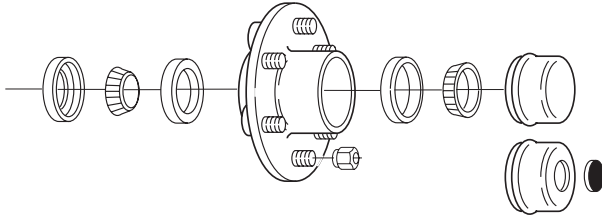

- 2788 Inner / 1779 Outer Bearings
- Capacity of 2,600 lbs. per each
- Fits #8 Spindle

Part No.	Ref. No.	Description
22834UC1	109400	Complete Hub Assembly
22834	109200	Hub Only
2788	129600	Inner Bearing
1779	129400	Outer Bearing
2729	134800	Inner Race
1729	134600	Outer Race
29031	159200	Grease Seal (3.00" O.D., 1.875" I.D.)
45896	151600	Grease Cap, 2.44" O.D., Drive-in
09251510	144750	Drive-in Stud, 1/2" Diameter
X1023R	140600	1/2" Cone Wheel Nut

## 8 Bolt, 6.5" Bolt Circle

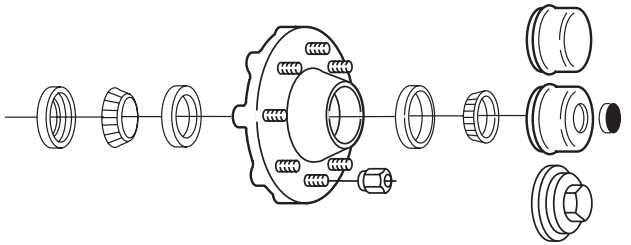

- 25580 Inner / 14125A Outer Bearings
- Capacity of 3,500 lbs. per each
- Fits Dexter 5,200 lb. thru 7,000 lb. axles
- For Spindles requiring 2 1/8" or 2 1/4" I.D. Grease Seal
- Std. Grease, E-Z Lube or Oil Bath Applications

Part No.	Ref. No.	Description
42865UC1	110600	Complete Hub Assembly - 2 1/4" I.D. Seal
42865UC1-EZ	110700	Complete E-Z Lube Hub Assembly - 2 1/4" I.D. Seal
42865	110400	Hub Only - for use w/ 2 1/4" I.D. Seal
8-231-9UC1	111000	Complete Hub Assembly - 2 1/8" I.D. Seal
8-231-9UC1-EZ	111025	Complete E-Z Lube Hub Assembly - 2 1/8" I.D. Seal
8-231-9	110800	Hub Only - for use w/ 2 1/8" I.D. Seal
8-231-16UC1	111075	Complete Oil Bath Hub Assembly w/ 2 1/8" I.D. Seal
8-231-16	111050	Hub Only - Oil Bath, for use w/ 2 1/8" I.D. Seal
25580	130800	Inner Bearing
14125A	130600	Outer Bearing
25520	136200	Inner Race
14276	136200	Outer Race
10-1	159800	Grease Seal (3.376" O.D., 2.125" I.D.)
42385	159600	Grease Seal (3.376" O.D., 2.25" I.D.)
10-10	160000	Grease Seal (3.376" O.D., 2.125" I.D.), For E-Z Lube & Oil Bath
38605	152200	Grease Cap, 2.75" O.D., Drive-in
21-43-1	152400	Grease Cap, 2.75" O.D., Drive-in, for E-Z Lube
85-1	155400	Grease Cap Plug for E-Z Lube
21-35	153800	Oil Cap Only, 2.875" Screw-in
46-32	155600	Oil Cap Plug
46-52	156000	Oil Hub Plug
10-45	156600	O-Ring Gasket for 21-35
7-122	144600	Drive-in Stud, 1/2" Diameter
X1023R	140600	1/2" Cone Wheel Nut



## 8 Bolt, 6.5" Bolt Circle

- 25580 Inner / 02475 Outer Bearings
- Fits Dexter 8,000 lb. axles
- Hub comes with 9/16" studs
- Oil Bath Hub

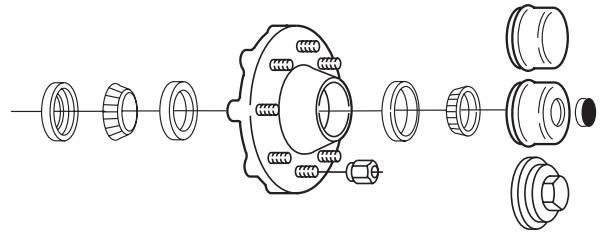

Part No.	Ref. No.	Description
8-231-14UC1	111850	Complete Hub Assembly - (4.56" Pilot), Old Style
8-287-14UC1	111900	Complete Hub Assembly - (4.75" Pilot), New Style
8-231-14	111650	Hub Only - (4.56" Pilot), Old Style
8-287-14	111875	Hub Only - (4.75" Pilot), New Style
25580	130800	Inner Bearing
02475	131000	Outer Bearing
25520	136200	Inner Race
02420	137000	Outer Race
10-48	161230	Oil Seal, (3.376" O.D., 2.375" I.D.), Use with 60-6 Wear Sleeve, Old Style
60-6	161235	Oil Seal Wear Sleeve, use with 10-48 Seal, Old Style
10-63	161225	Unitized Oil Seal (3.376" O.D., 2.250" I.D.), New Style
21-35	153800	Oil Cap Only, 2.875" O.D., Screw-in
10-45	156600	O-Ring Gasket for 21-35
46-32	155600	Oil Cap Plug
46-52	156000	Oil Hub Plug
25-47	148600	Screw-in Stud, 9/16" Diameter
7-132	145200	Drive-in Stud, 9/16" Diameter
7-115	145600	Drive-in Stud, 5/8" Diameter (optional)
6-53	140800	9/16" Cone Wheel Nut
6-109	141000	5/8" Cone Wheel Nut (optional)



## Replacement Hub and Drum Assemblies

### 4 Bolt, 4" Bolt Circle

AXLE  
COMPONENTS

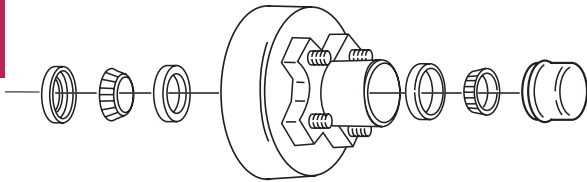

- L44643 Inner / Outer Bearings
- Capacity of 1,250 lbs. per each
- Fits BT8 1" spindle
- Drum size: 7" x 1 3/4"

Part No.	Ref. No.	Description
HD700AUC3	115000	Complete Hub and Drum Assembly - Includes the following:
HD700A	114800	Hub and Drum Only
L44643	128800	Inner / Outer Bearing
L44610	134400	Inner / Outer Race
34823	157800	Grease Seal (1.983" O. D., 1.249" I.D.)
46749	151200	Grease Cap, 1.986" O.D., Drive-in
25-53	147800	Screw-in Stud, 1/2" Diameter
X1023R	140600	1/2" Cone Wheel Nut

### 4 Bolt, 4" Bolt Circle

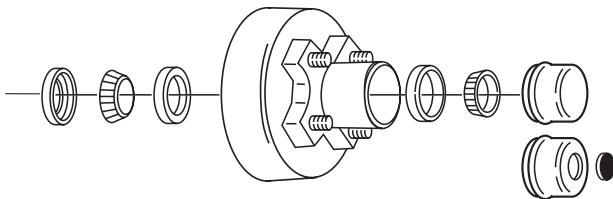

- L44649 Inner / Outer Bearings
- Fits Dexter 2,000 lb. axle
- BTR 1 1/16" Spindle
- Std. Grease or E-Z Lube application
- Drum Size: 7" x 1 3/4"

Part No.	Ref. No.	Description
HD701BUC3	115400	Complete Hub and Drum Assembly
HD701BUC3-EZ	115425	Complete E-Z Lube Hub and Drum Assembly
HD700A	114800	Hub and Drum Only
L44649	129000	Inner / Outer Bearing
L44610	134400	Inner / Outer Race
10-9	158000	Grease Seal (1.987" O. D., 1.5" I.D.)
10-60	158200	Grease Seal (1.987" O. D., 1.5" I.D.) for E-Z Lube
46749	151200	Grease Cap, 1.986" O.D., Drive-in
21-3-1	151400	Grease Cap, 1.986" O.D., Drive-in, for E-Z Lube
85-1	155400	Grease Cap Plug for E-Z Lube
25-53	147800	Screw-in Stud, 1/2" Diameter
X1023R	140600	1/2" Cone Wheel Nut



## 4 Bolt, 9.4" Bolt Circle

- Fits #84 Spindle, L68149 Inner / L44649 Outer Bearings
- Capacity of 1,750 lbs. per each
- Available in Std. Grease or E-Z Lube Application
- Drum Size: 10" x 2 1/4"

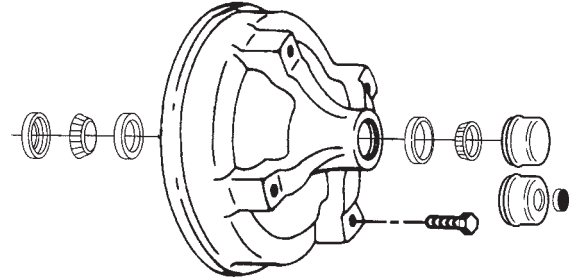

AXLE  
COMPONENTS

Part No.	Ref. No.	Description
8-245-4UC3	118600	Complete Hub and Drum Assembly
8-245-4UC3-EZ	118625	Complete E-Z Lube Hub and Drum Assembly
8-245-4	118400	Hub and Drum Only
L68149	129200	Inner Bearing
L44649	129000	Outer Bearing
L68111	135000	Inner Race
L44610	134400	Outer Race
58846	158800	Grease Seal (2.565" O. D., 1.719" I.D.)
10-19	159000	Grease Seal (2.565" O. D., 1.719" I.D.) for E-Z Lube
46749	151200	Grease Cap, 1.986" O.D., Drive-in
21-3-1	151400	Grease Cap, 1.986" O.D., Drive-in, for E-Z Lube
85-1	155400	Grease Cap Plug for E-Z Lube
X1064	143200	Wheel Bolt, 1/2" Diameter



## 4 Bolt, 9.4" Bolt Circle

- Fits Dexter 5,200 lb. and 6,000 lb. axles,  
25580 Inner / LM67048 Outer Bearings
- Capacity of 3,000 lbs. per each
- Available in Std. Grease or E-Z Lube Application
- Drum Size: 12" x 2"

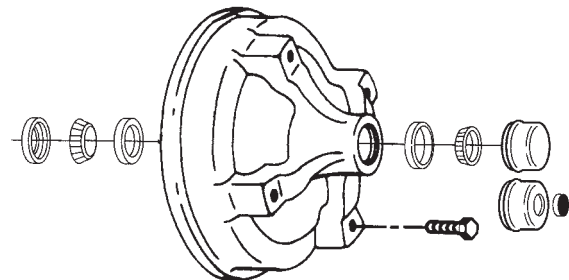

Part No.	Ref. No.	Description
8-155-4UC3	120600	Complete Hub and Drum Assembly
8-155-4UC3-EZ	120625	Complete E-Z Lube Hub and Drum Assembly
8-155-4	120400	Hub and Drum Only
25580	130800	Inner Bearing
LM67048	130000	Outer Bearing
25520	136200	Inner Race
LM67010	136200	Outer Race
10-1	159800	Grease Seal (3.376" O. D., 2.125" I.D.)
10-10	160000	Grease Seal (3.376" O. D., 2.125" I.D.) for E-Z Lube
45896	151600	Grease Cap, 2.44" O.D., Drive-in
21-1-1	151800	Grease Cap, 2.44" O.D., Drive-in, for E-Z Lube
85-1	155400	Grease Cap Plug for E-Z Lube
X1064	143200	Wheel Bolt, 1/2" Diameter



## 5 Bolt, 4.5" Bolt Circle

AXLE  
COMPONENTS

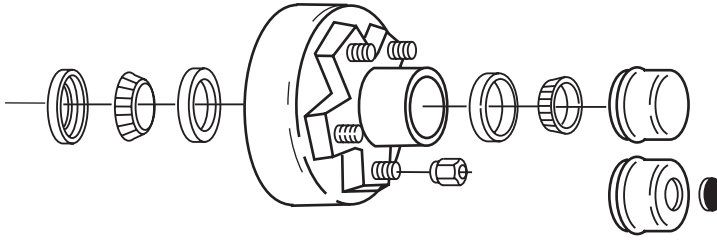

- Fits BT8 1" Spindle, L44643 Inner / Outer Bearings
- Capacity of 1,250 lbs. per each
- Drum Size: 7" x 1 3/4"

Part No.	Ref. No.	Description
HD702CUC3	115800	Complete Hub and Drum Assembly
HD702C	115600	Hub and Drum Only
L44643	128800	Inner / Outer Bearing
L44610	134400	Inner / Outer Race
34823	157800	Grease Seal (1.983" O. D., 1.249" I.D.)
46749	151200	Grease Cap, 1.986" O.D., Drive-in
25-53	147800	Screw-in Stud, 1/2" Diameter
X1023R	140600	1/2" Cone Wheel Nut

## 5 Bolt, 4.5" Bolt Circle

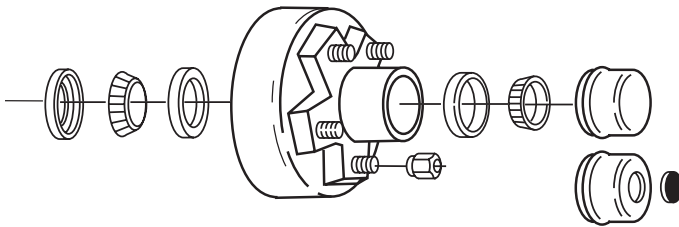

- Fits Dexter 2,000 lb. axle, 1 1/16" spindle, L44649 Inner / Outer Bearings
- Available in Standard or E-Z Lube application
- Drum Size: 7" x 1 3/4"

Part No.	Ref. No.	Description
HD703DUC3	116200	Complete Hub and Drum Assembly
HD703DUC3-EZ	116225	Complete E-Z Lube Hub and Drum Assembly
HD702C	115600	Hub and Drum Only
L44649	129000	Inner / Outer Bearing
L44610	134400	Inner / Outer Race
10-9	158000	Grease Seal (1.987" O. D., 1.5" I.D.)
10-60	158200	Grease Seal (1.987" O. D., 1.5" I.D.) for E-Z Lube
46749	151200	Grease Cap, 1.986" O.D., Drive-in
21-3-1	151400	Grease Cap, 1.986" O.D., Drive-in, for E-Z Lube
85-1	155400	Grease Cap Plug for E-Z Lube
25-53	147800	Screw-in Stud, 1/2" Diameter
X1023R	140600	1/2" Cone Wheel Nut



## 5 Bolt, 4.5", 4.75", 5", 5.5" Bolt Circle

- Fits #84 Spindle, L68149 Inner / L44649 Outer Bearings.
- Capacity of 1,750 lbs. per each
- Available in Standard or E-Z Lube Application
- Used on Dexter and most 3,500 lb axles
- Drum Size: 10" x 2 1/4"
- 4 Different Bolt Patterns

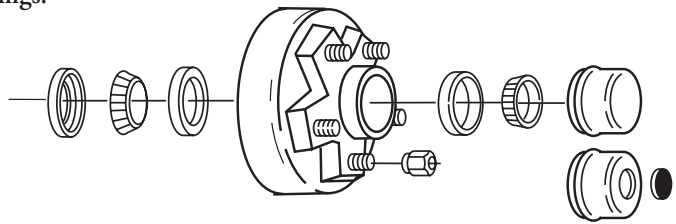

AXLE  
COMPONENTS

Part No.	Ref. No.	Description
84546UC3	116600	Complete Hub and Drum Assembly, 4.5" Bolt Circle
84546UC3-EZ	116625	Complete E-Z Lube Hub and Drum Assembly, 4.5" Bolt Circle
84546	116400	Hub and Drum Only, 4.5" Bolt Circle
845476UC3	117000	Complete Hub and Drum Assembly, 4.75" Bolt Circle
845476UC3-EZ	117025	Complete E-Z Lube Hub and Drum Assembly, 4.75" Bolt Circle
845476	116800	Hub and Drum Only, 4.75" Bolt Circle
84556UC3	117400	Complete Hub and Drum Assembly, 5" Bolt Circle
84556UC3-EZ	117425	Complete E-Z Lube Hub and Drum Assembly, 5" Bolt Circle
84556	117200	Hub and Drum Only, 5" Bolt Circle
84557UC3	117800	Complete Hub and Drum Assembly, 5.5" Bolt Circle
84557UC3-EZ	117825	Complete E-Z Lube Hub and Drum Assembly, 5.5" Bolt Circle
84557	117600	Hub and Drum Only, 5.5" Bolt Circle
L68149	129200	Inner Bearing
L44649	129000	Outer Bearing
L68111	135000	Inner Race
L44610	134400	Outer Race
58846	158800	Grease Seal (2.565" O. D., 1.719" I.D.)
10-19	159000	Grease Seal (2.565" O. D., 1.719" I.D.) for E-Z Lube
46749	151200	Grease Cap, 1.986" O.D., Drive-in
21-3-1	151400	Grease Cap, 1.986" O.D., Drive-in, for E-Z Lube
85-1	155400	Grease Cap Plug for E-Z Lube
7-122	144600	Drive-in Stud, 1/2" Diameter
X1023R	140600	1/2" Cone Wheel Nut



## 6 Bolt, 5.5" Bolt Circle

- Fits #84 Spindle, L68149 Inner / L44649 Outer Bearings
- Capacity of 1,750 lbs. per each
- Available in Standard or E-Z Lube Application
- Used on Dexter and most 3,500 lb. Axles
- Drum Size: 10" x 2 1/4"

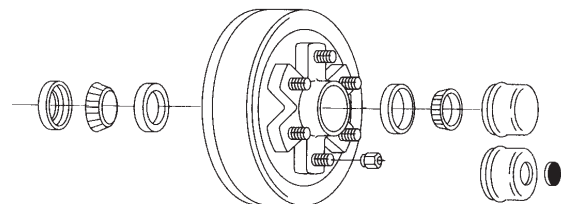

Part No.	Ref. No.	Description
84656UC3	118200	Complete Hub and Drum Assembly
84656UC3-EZ	118225	Complete E-Z Lube Hub and Drum Assembly
84656	118000	Hub and Drum Only



Components for this hub are the same as listed in the table above

## 6 Bolt, 5.5" Bolt Circle

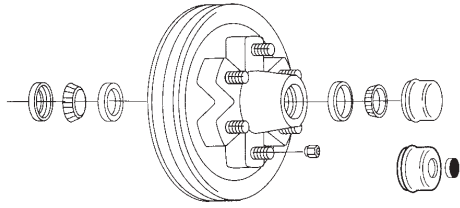

- Fits Dexter 5,200 lb. and 6,000 lb. Axles, #42 Spindle, 25580 Inner / 15123 Outer Bearings
- Capacity of 3,000 lbs. per each
- For Spindles requiring a 2 1/8" or 2 1/4" I.D. Grease Seal
- Drum Size: 12" x 2"

Part No.	Ref. No.	Description
42656UC3	119000	Complete Hub and Drum Assembly w/ 2 1/4" I.D. Seal
42656UC3-EZ	119050	Complete E-Z Lube Hub and Drum Assembly w/ 2 1/4" I.D. Seal
8-201-9UC3	119100	Complete Hub and Drum Assembly w/ 2 1/8" I.D. Seal
8-201-9UC3-EZ	119150	Complete E-Z Lube Hub and Drum Assembly w/ 2 1/8" I.D. Seal
42656	118800	Hub and Drum Only
25580	130800	Inner Bearing
15123	130400	Outer Bearing
25520	136200	Inner Race
15245	135600	Outer Race
42385	159600	Grease Seal (3.376" O. D., 2.25" I.D.)
10-1	159800	Grease Seal (3.376" O.D., 2.125" I.D.)
10-10	160000	Grease Seal (3.376" O.D., 2.125" I.D.), for E-Z Lube
45896	151600	Grease Cap, 2.44" O.D., Drive-in
21-1-1	151800	Grease Cap, 2.44" O.D., Drive-in, for E-Z Lube
85-1	155400	Grease Cap Plug for E-Z Lube
7-122	144600	Drive-in Stud, 1/2" Diameter
X1023R	140600	1/2" Cone Wheel Nut



## 6 Bolt, 5.5" Bolt Circle

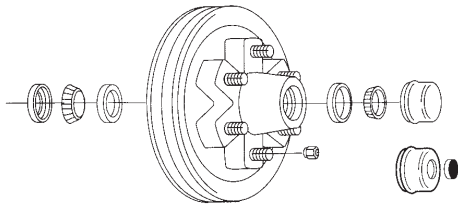

- Fits Dexter 5,200 lb. and 6,000 lb. Axles, 25580 Inner / LM67048 Outer Bearings
- Capacity of 3,000 lbs. per each
- Available in Standard or E-Z Lube application
- Drum Size: 12" x 2"

Part No.	Ref. No.	Description
8-201-5UC3	119400	Complete Hub and Drum Assembly
8-201-5UC3-EZ	119425	Complete E-Z Lube Hub and Drum Assembly
8-201-5	119200	Hub and Drum only
25580	130800	Inner Bearing
LM67048	130000	Outer Bearing
25520	136200	Inner Race
LM67010	135400	Outer Race
10-1	159800	Grease Seal (3.376" O.D., 2.125" I.D.)
10-10	160000	Grease Seal (3.376" O.D., 2.125" I.D.), for E-Z Lube
45896	151600	Grease Cap, 2.44" O.D., Drive-in
21-1-1	151800	Grease Cap, 2.44" O.D., Drive-in, for E-Z Lube
85-1	155400	Grease Cap Plug for E-Z Lube
7-122	144600	Drive-in Stud, 1/2" Diameter
X1023R	140600	1/2" Cone Wheel Nut





## 5 Spoke, Utility Type (Grease & Oil)

- Fits Dexter 6,000 lb. and 7,000 lb. Axles,  
25580 Inner / 15123 Outer Bearings
- Capacity of 3,500 lbs. per each
- Drum Size: 12" x 2"
- Std. Grease, E-Z Lube or Oil Bath Application

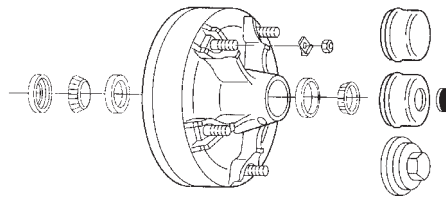

Part No.	Ref. No.	Description
8-174-5UC3	121000	Complete Hub and Drum Assembly, Grease
8-174-5UC3-EZ	121010	Complete E-Z Lube Hub and Drum Assembly, Grease
8-174-5	120800	Hub and Drum Only, Grease
8-174-6UC3	121050	Complete Oil Bath Hub and Drum Assembly
8-174-6	121025	Hub and Drum Only, Oil Bath
25580	130800	Inner Bearing
15123	130400	Outer Bearing
25520	136200	Inner Race
15245	135600	Outer Race
10-1	159800	Grease Seal (3.376" O.D., 2.125" I.D.)
10-10	160000	Grease Seal (3.376" O.D., 2.125" I.D.), for E-Z Lube
45896	151600	Grease Cap, 2.44" O.D., Drive-in
21-1-1	151800	Grease Cap, 2.44" O.D., Drive-in, for E-Z Lube
85-1	155400	Grease Cap Plug for E-Z Lube
21-40	153600	Oil Cap, 2.563" O.D., Screw-in
10-59	156825	O-Ring Gasket for 21-40 Oil Cap
46-52	156000	Oil Hub Plug
15-2	149600	Rim Clamp
25-11	148200	Screw-in Stud, 9/16" Diameter
916N	078400	9/16" Wheel Nut



## 8 Bolt, 6.5" Bolt Circle

- Fits #99 Spindle,  
28580 Inner, 25580 Outer Bearing
- Drum Size: 12" x 2"

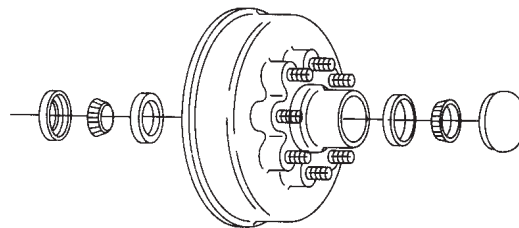

Part No.	Ref. No.	Description
99865UC3	121400	Complete Hub and Drum Assembly
99865	121200	Hub and Drum Only
28580	132200	Inner Bearing
25580	130800	Outer Bearing
28521	136800	Inner Race
25520	136200	Outer Race
T51153	160200	Grease Seal (3.623" O.D., 2.375" I.D.)
75DC	153000	Grease Cap, 3.375" O.D., Drive-in
165995	145000	Drive-in Stud, 1/2" Diameter
X1023R	140600	1/2" Cone Wheel Nut

## 8 Bolt, 6.5" Bolt Circle

AXLE  
COMPONENTS

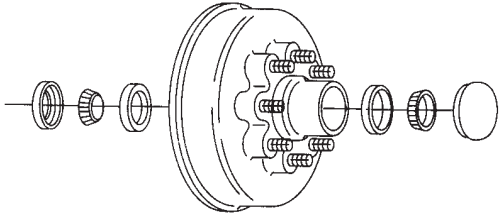

- Fits Dexter 5,200 lb. thru 7,000 lb. Axles  
#42 Spindle, 25580 Inner / 14125A Outer Bearings
- Capacity of 3,500 lbs. per each
- For Spindles Requiring 2 1/4" or 2 1/8" I.D. Seal
- Drum Size 12" x 2"
- Available in Standard, E-Z Lube or Oil Bath applications

Part No.	Ref. No.	Description
42866UC3	119800	Complete Hub and Drum Assembly w/ 2 1/4" I.D. Seal
42866UC3-EZ	119810	Complete E-Z Lube Hub and Drum Assembly w/ 2 1/4" I.D. Seal
42866	119600	Hub and Drum Only, Grease/EZ Lube
8-219-4UC3	120200	Complete Hub and Drum Assembly w/ 2 1/8" I.D. Seal
8-219-4UC3-EZ	120225	Complete E-Z Lube Hub and Drum Assembly w/ 2 1/8" I.D. Seal
8-219-9	120250	Hub and Drum Only, Oil Bath
8-219-9UC3	120275	Complete Oil Bath Hub and Drum Assembly w/ 2 1/8" I.D. Seal
8-219-9UC3A	120280	Complete Oil Bath Hub and Drum Assembly w/ 2 1/4" I.D. Seal
25580	130800	Inner Bearing
14125A	130600	Outer Bearing
25520	136200	Inner Race
14276	135800	Outer Race
42385	159600	Grease Seal (3.376" O.D., 2.25" I.D.)
38605	152200	Grease Cap, 2.75" O.D., Drive-in
21-43-1	152400	Grease Cap for E-Z Lube
10-10	160000	Seal (3.376" O.D., 2.125" I.D.), for E-Z Lube & Oil Bath
10-63	161225	Unitized Oil Seal (3.376" O.D., 2.25" I.D.)
21-35	153800	Oil Cap Only, 2.875" O.D., Screw-in
10-45	156600	O-Ring Gasket for 21-35 Oil Cap
85-1	155400	Grease Cap Plug for E-Z Lube
46-32	155600	Oil Cap Plug
46-52	156000	Oil Hub Plug
7-122	144600	Drive-in Stud, 1/2" Diameter
X1023R	140600	1/2" Cone Wheel Nut



## 8 Bolt, 6.5" Bolt Circle

- Fits Dexter 7,200 lb. Axles,  
25580 Inner / 02475 Outer Bearings
- Oil Bath, Grease or E-Z Lube
- Hub comes with  $\frac{9}{16}$ " or  $\frac{5}{8}$ " studs
- Drum Size: 12  $\frac{1}{4}$ " x 2  $\frac{1}{2}$ "

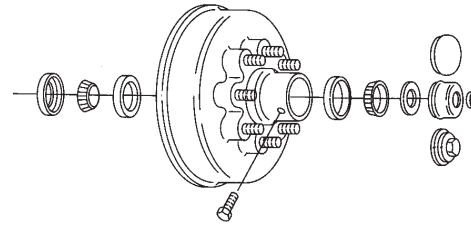

In February 2000, the 7,200 lb. axle was upgraded from a 9-bolt to a 4-bolt brake flange. Be sure to verify flange type before making your selection, hub/drums will not interchange.

Part No.	Ref. No.	Description
8-355-12	122355	Hub & drum only, oil bath, 9/16" stud (9-bolt flange)
8-355-12UC3	122360	Complete hub & drum assembly, oil bath, 9/16" stud (9-bolt flange)
8-393-3	122361	Hub & drum only, oil bath, 9/16" stud (4-bolt flange)
8-393-3UC3	122362	Complete hub & drum assembly, oil bath, 9/16" stud (4-bolt flange)
8-355-13	122363	Hub & drum only, grease, 9/16" stud (9-bolt flange)
8-355-13UC3	122365	Complete hub & drum assembly, grease, 9/16" stud (9-bolt flange)
8-355-13UC3-EZ	122370	Complete EZ Lube hub & drum assembly, grease, 9/16" stud (9-bolt flange)
8-393-4	122375	Hub & drum only, grease, 9/16" stud (4-bolt flange)
8-393-4UC3	122377	Complete hub & drum assembly, grease, 9/16" stud (4-bolt flange)
8-393-4UC3-EZ	122380	Complete EZ Lube hub & drum assembly, grease, 9/16" stud (4-bolt flange)
8-355-14	122425	Hub & drum only, oil bath, 5/8" stud (9-bolt flange)
8-355-14UC3-A	122430	Complete hub & drum assembly, oil bath, 5/8" flg nuts (9-bolt flange)
8-355-14UC3-B	122435	Complete hub & drum assembly, oil bath, 5/8" cone nuts (9-bolt flange)
8-393-5	122436	Hub & drum only, oil bath, 5/8" stud (4-bolt flange)
8-393-5UC3-A	122437	Complete hub & drum assembly, oil bath, 5/8" flg nuts (4-bolt flange)
8-393-5UC3-B	122438	Complete hub & drum assembly, oil bath, 5/8" cone nuts (4-bolt flange)
8-355-15	122440	Hub & drum only, grease, 5/8" stud (9-bolt flange)
8-355-15UC3-A	122445	Complete hub & drum assembly, grease, 5/8" flg nuts (9-bolt flange)
8-355-15UC3-B	122450	Complete hub & drum assembly, grease, 5/8" cone nuts (9-bolt flange)
8-355-15UC3-EZA	122455	Complete EZ Lube hub & drum assembly, grease, 5/8" flg nuts (9-bolt flange)
8-355-15UC3-EZB	122460	Complete EZ Lube hub & drum assembly, grease, 5/8" cone nuts (9-bolt flange)
8-393-6	122462	Hub & drum only, grease, 5/8" stud (4-bolt flange)
8-393-6UC3-A	122463	Complete hub & drum assembly, grease, 5/8" flg nuts (4-bolt flange)
8-393-6UC3-B	122464	Complete hub & drum assembly, grease, 5/8" cone nuts (4-bolt flange)
8-393-6UC3-EZA	122465	Complete EZ Lube hub & drum assembly, grease, 5/8" flg nuts (4-bolt flange)
8-393-6UC3-EZB	122466	Complete EZ Lube hub & drum assembly, grease, 5/8" cone nuts (4-bolt flange)
25580	130800	Inner Bearing
02475	131000	Outer Bearing
10-63	161225	Unitized Oil Seal (3.376" O.D., 2.250" I.D.)
21-43-1	152400	Grease Cap, 2.72" O.D. Drive-in for E-Z Lube
38605	152200	Grease Cap, 2.75" O.D. Drive-in
22-03	154800	Oil Cap Complete
85-1	155400	Grease Cap Plug, For All E-Z Lube Grease Caps
7-223	145300	Drive-in Stud, 9/16" Diameter
7-224	145350	Drive-in Stud, 5/8" Diameter
6-53	140800	9/16" Cone Wheel Nut
6-109	141000	5/8" Cone Wheel Nut
95188	141600	5/8" Flange Wheel Nut



## 8 Bolt, 6.5" Bolt Circle

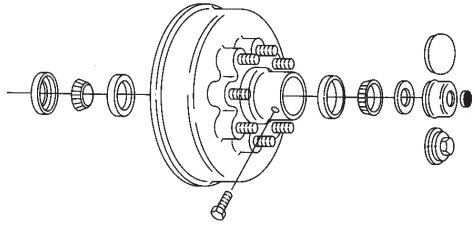

- Fits Dexter 7,500 lb. Axles,  
25580 Inner / 02475 Outer Bearings
- Oil Bath Hub and Drum
- Replacement Hub and Drum comes with  $\frac{5}{8}$ " Studs.
- Drum Size: 12" x 3"

Part No.	Ref. No.	Description
8-187-7UC3	122200	Complete Hub and Drum Assembly
8-187-7	122000	Hub and Drum Only
25580	130800	Inner Bearing
02475	131000	Outer Bearing
25520	136200	Inner Race
02420	137000	Outer Race
10-48	161230	Oil Seal, (3.376" O.D., 2.375" I.D.), Use With 60-6 Weare Sleeve
60-6	161235	Oil Seal Wear Sleeve, Use with 10-48 Seal
21-35	153800	Oil Cap Only, 2.875" O.D., Screw-in
10-45	156600	O-Ring Gasket for 21-35 Oil Cap
46-32	155600	Oil Cap Plug
46-52	156000	Oil Hub Plug
25-47	148600	Screw-in Stud 9/16" Diameter
25-48	148800	Screw-in Stud, 5/8" Diameter
6-53	140800	9/16" Cone Wheel Nut
6-109	141000	5/8" Cone Wheel Nut



## 8 Bolt, 6.5" Bolt Circle

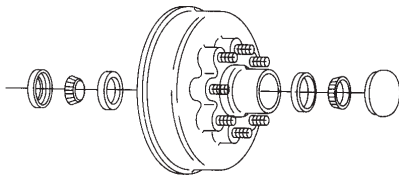

- Fits Hayes 8,000 lb. Axles,  
25580 Inner / 02475 Outer Bearings
- Drum Size: 12" x 3  $\frac{1}{4}$ "
- Grease or Oil Bath Hub

Part No.	Ref. No.	Description
9080598UC3	122350	Complete Hub and Drum Assembly, Grease
9080598	122340	Hub and Drum Only, Grease
9080648UC3	122325	Complete Hub and Drum Assembly, Oil Bath
9080648	122300	Hub and Drum Only, Oil Bath
25580	130800	Inner Bearing
02475	131000	Outer Bearing
25520	136200	Inner Race
02420	137000	Outer Race
9103309	161227	Oil Seal, (3.376" O.D., 2.25" I.D.)
42385	159600	Grease Seal (3.376" O.D., 2.25" I.D.)
6-53	140800	9/16" Cone Wheel Nut
38605	152200	Grease Cap 2.75" O.D. Drive-in
92128	154100	Oil Cap Only
92126	155800	Oil Cap Plug
92130	156850	O-Ring Gasket

## 8 Bolt, 6.5" Bolt Circle

- Fits Dexter 8,000 lb. Axles,  
25580 Inner / 02475 Outer Bearings
- Oil Bath or E-Z Lube
- Hub comes with 9/16" or 5/8" studs
- 4.56" (Old Style) or 4.75" (New Style) Hub Pilot
- Drum Size: 12 1/4" x 3 3/8"
- Available with or without ABS exciter ring installed.

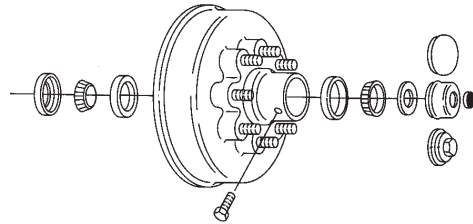

AXLE  
COMPONENTS

Standard Hub / Drums			ABS Hubs / Drums	
Part No.	Ref. No.	Description	Part No.	Ref No.
8-218-9	122575	Hub and Drum Only (4.56" Pilot) Oil Bath - 9/16" Studs	N/A	N/A
8-218-9UC3	122600	Complete Hub and Drum Assembly (4.56" Pilot) Oil Bath - 9/16" Studs	N/A	N/A
8-285-8	123010	Hub and Drum Only, (4.75" Pilot) E-Z Lube - 5/8" Studs	8-285-15	123096
8-285-8UC3-A	123015	Complete Hub and Drum Assembly (4.75" Pilot) E-Z Lube - Studs & 95188 Nut	5/8" 8-285-15UC3-A	123098
8-285-8UC3-B	123020	Complete Hub and Drum Assembly (4.75" Pilot) E-Z Lube - Studs & 6-109 Nut	5/8" 8-285-15UC3-B	123099
8-285-9	123025	Hub and Drum Only (4.75" Pilot) Oil Bath - 9/16" Studs	8-285-12	123082
8-285-9UC3	123050	Complete Hub and Drum Assembly (4.75" Pilot) Oil Bath - 9/16" Studs	8-285-12UC3	123084
8-285-10	123055	Hub and Drum Only, (4.75" Pilot), Oil Bath - 5/8" Studs	8-285-14	123090
8-285-10UC3-A	123060	Complete Hub and Drum Assembly (4.75" Pilot) Oil Bath - 5/8" Studs & 95188 Nut	8-285-14UC3-A	123092
8-285-10UC3-B	123065	Complete Hub and Drum Assembly (4.75" Pilot) Oil Bath - 5/8" Studs & 6-109 Nut	8-285-14UC3-B	123094
8-285-11	123075	Hub and Drum Only (4.75" Pilot) E-Z Lube - 9/16" Studs	8-285-13	123086
8-285-11UC3	123080	Complete Hub and Drum Assembly (4.75" Pilot) E-Z Lube 9/16" Studs	8-285-13UC3	123088



### Replacement Components

Part No.	Ref. No.	Description
25580	130800	Inner Bearing
02475	131000	Outer Bearing
25520	136200	Inner Race
02420	137000	Outer Race
10-63	161225	Unitized Oil Seal (3.376" O.D., 2.250" I.D.)
10-36	159700	Grease Seal, Double Lip, (3.376" O.D., 2.25" I.D.), for E-Z Lube
21-43-1	152400	Grease Cap, 2.72" O.D. Drive-in for E-Z Lube
21-35	153800	Oil Cap Only, 2.875" O.D., Screw-in
10-45	156600	O-Ring Gasket for 21-35
85-1	155400	Grease Cap Plug, for All E-Z Lube Grease Caps
46-32	155600	Oil Cap Plug
46-52	156000	Oil Hub Plug
7-132	145200	Drive-in Stud, 9/16" Diameter
7-232	145400	Drive-in Stud, 5/8" Diameter
6-53	140800	9/16" Cone Wheel Nut
6-109	141000	5/8" Cone Wheel Nut
95188	141600	5/8" Flange Wheel Nut

## 8 Bolt, 6.5" Bolt Circle

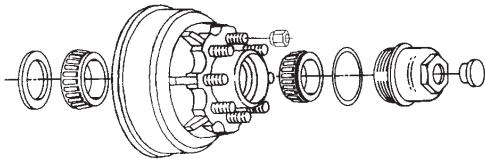

- Fits #99 Spindle, 28580 Inner / 25580 Outer Bearings
- Oil Bath Hub (Dual Wheel)
- Drum Size: 12 1/4" x 3 1/2"

Part No.	Ref. No.	Description
9080568UC3	121800	Complete Hub and Drum Assembly
9080568	121600	Hub and Drum Only
28580	132200	Inner Bearing
25580	130800	Outer Bearing
28521	136800	Inner Race
25520	136200	Outer Race
91030	163000	Oil Seal, (3.779" O.D., 2.750" I.D.)
92125	154200	Oil Cap Only, 3.750" O.D., Screw-in
92126	155800	Oil Cap Plug for 92125
92127	157000	O-Ring Gasket for 92125
9251513	146400	Drive-in Stud, 5/8" Diameter
95188	141600	5/8" Flanged Wheel Nut

## 8 Bolt, 6.5" Bolt Circle

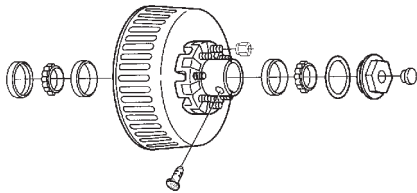

- Oil Bath hub, 25580 Inner / 2585 Outer Bearing
- Fits Dexter 9K Axles, "Old Style"
- Drum Size: 12 1/4" x 3 3/8"

Part No.	Ref. No.	Description
8-232-5UC3	121800	Complete Hub and Drum Assembly (4.56" Pilot)
8-232-5	122800	Hub and Drum Only (4.56" Pilot)
8-286-5UC3	122650	Complete Hub and Drum Assembly (4.75" Pilot)
8-286-5	122625	Hub and Drum Only (4.75" Pilot, MFG 04-15 Thru 10-01-89)
25580	130800	Inner Bearing
2585	131200	Outer Bearing
25520	136200	Inner Race
2520	137200	Outer Race
10-48	161230	Oil Seal, (3.376" O.D., 2.375" I.D.)
60-6	161235	Oil Wear Sleeve, use with 10-48
10-63	161225	Unitized Oil Seal (3.376" O.D., 2.25" I.D.)
21-35	153800	Oil Cap, (2.875" O.D.), Screw-in
10-45	156600	O-Ring Gasket for 21-35 Oil Cap
46-32	155600	Oil Cap Plug
46-52	156000	Oil Hub Plug
7-115	145600	Drive-in Stud, 5/8" Diameter
33-52-1	142800	Wheel Retaining Ring
6-109	141000	5/8" Cone Wheel Nut



## 8 Bolt, 6.5" Bolt Circle

- Oil Bath Hub, 387A Inner / 25580 Outer Bearing
- Fits Dexter 9K (after 10/89) and 10K General Duty
- Capacity of 5,000 lbs. per each
- Drum Size: 12 1/4" x 3 3/8"
- Drum Available with ABS exciter ring installed

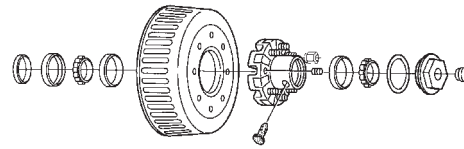

Part No.	Ref. No.	Description
8-288-3UC1	111920	Complete Hub Assembly (does not include brake drum or mtg bolts)
8-288-3	111910	Hub Only
9-44-1	124390	Brake Drum Only, Non-ABS
9-44-3	124395	Brake Drum Only, with ABS exciter ring
7-101	150500	Drum Mounting Bolt
387A	131400	Inner Bearing
25580	130800	Outer Bearing
382A	137400	Inner Race
25520	136200	Outer Race
10-51	161650	Unitized Oil Seal, (3.88" O.D., 2.875" I.D.)
21-36	153975	Oil Cap Only, 4.00" O.D., Screw-in, Plastic
10-50	156800	O-Ring Gasket for 21-36
46-32	155600	Oil Cap Plug
46-52	156000	Oil Hub Plug
7-115	145600	Drive-in Stud, 5/8" Diameter
33-52-1	142800	Wheel Retaining Ring
6-109	141000	5/8" Cone Wheel Nut



## 8 Bolt, 6.5" Bolt Circle

- Oil Bath Hub, 395S Inner / 387A Outer Bearing
- Capacity of 5,000 lbs. per each
- Fits Dexter 10K Axles
- Drum Size: 12 1/4" x 4"
- Drum Available with ABS exciter ring installed

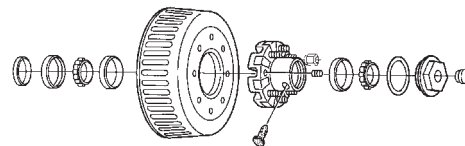

Part No.	Ref. No.	Description
8-214-5UC1	112200	Complete Hub Assembly (does not include brake drum or mtg bolts)
8-214-5	112000	Hub Only
9-27-1	124400	Brake Drum Only, Non-ABS
9-27-3	124405	Brake Drum Only, with ABS exciter ring
7-103	150600	Drum Mounting Bolt
395S	131600	Inner Bearing
387A	131400	Outer Bearing
394A	137600	Inner Race
382A	137400	Outer Race
10-56	162000	Unitized Oil Seal, (4.50" O.D., 3.125" I.D.)
21-36	153975	Oil Cap Only, 4.00" O.D., Screw-in, Plastic
10-50	156800	O-Ring Gasket for 21-36
46-32	155600	Oil Cap Plug
46-52	156000	Oil Hub Plug
7-115	145600	Drive-in Stud, 5/8" Diameter
33-52-1	142800	Wheel Retaining Ring
6-109	141000	5/8" Cone Wheel Nut



## 8 Bolt, 6.5" Bolt Circle

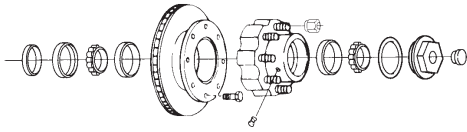

- Oil Bath hub, 395S Inner / 387A Outer Bearings
- Capacity of 5,000 lbs. per each
- Fits Dexter 10K Disc Brake Axles
- Rotor Available with ABS exciter ring installed

Part No.	Ref. No.	Description
8-214-6UC1	112220	Complete Hub Assembly (does not include rotor or mtg hardware)
8-214-6	112210	Hub Only
70-006	124950	Brake Rotor Only, Non-ABS
70-006-2	124955	Brake Rotor Only, with ABS exciter ring
25-14	150825	Brake Rotor Mounting Stud
6-46	193000	Rotor Mounting Nut
395S	131600	Inner Bearing
387A	131400	Outer Bearing
394A	137600	Inner Race
382A	137400	Outer Race
10-56	162000	Unitized Oil Seal, (4.50" O.D., 3.125" I.D.)
21-36	153975	Oil Cap Only, 4.00" O.D., Screw-in, Plastic
10-50	156800	O-Ring Gasket for 21-36
46-32	155600	Oil Cap Plug
46-52	156000	Oil Hub Plug
7-115	145600	Drive-in Stud, 5/8" Diameter
33-52-1	142800	Wheel Retaining Ring
6-109	141000	5/8" Cone Wheel Nut



## 8 Bolt, 6.5" Bolt Circle

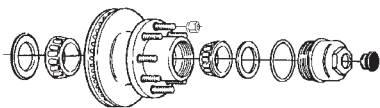

- Oil Bath Hub, JM11946 Inner / JM205149 Outer Bearing
- Fits Hayes 10K Disc Brake Axles
- Capacity of 5,000 lbs. per each

Part No.	Ref. No.	Description
090814UC3	125200	Complete Hub & Rotor Assembly
090814	125000	Hub and Rotor Only
JM511946	132800	Inner Bearing
JM205149	132600	Outer Bearing
JM511910	138400	Inner Race
JM205110	138200	Outer Race
10-56	162000	Unitized Oil Seal, (4.50" O.D., 3.125" I.D.)
92125	154200	Oil Cap Only, 3.75" O.D., Screw-in
92126	155800	Oil Cap Plug
92127	157000	O-Ring Gasket for 92125 Oil Cap
090737	145800	Drive-in Stud, 5/8" Diameter
95188	141600	5/8" Flanged Wheel Nut



## 8 Bolt, 6.5" Bolt Circle

- Oil Bath Hub, 3984 Inner / 28682 Outer Bearing
- Capacity of 6,000 lbs. per each
- Fits Dexter 12K Axles, Hi or Lo-Profile
- Drum Size: 12 1/4" x 5"
- Drum Available with ABS exciter ring installed

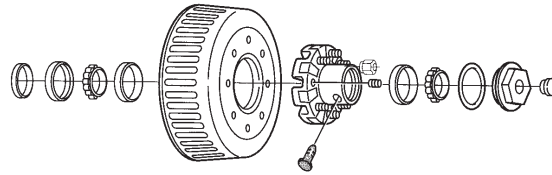

Part No.	Ref. No.	Description
8-214-8UC1	113000	Complete Hub Assembly (16" & 16.5" Diameter Wheels)
8-214-8	112800	Hub Only (16" & 16.5" Diameter Wheels)
8-216-5UC1	112600	Complete Hub Assembly (14.5" Diameter Wheels)
8-216-5	112400	Hub Only (14.5" Diameter Wheels)
9-28-1	124600	Brake Drum Only, Non-ABS
9-28-5	124605	Brake Drum Only, with ABS exciter ring
7-103	150600	Drum Mounting Bolt
3984	131800	Inner Bearing
28682	132000	Outer Bearing
3920	138000	Inner Race
28622	137800	Outer Race
10-56	162000	Unitized Oil Seal, (4.50" O.D., 3.125" I.D.)
21-36	153975	Oil Cap Only, 4.00" O.D., Screw-in, Plastic
10-50	156800	O-Ring Gasket for 21-36
46-32	155600	Oil Cap Plug
46-52	156000	Oil Hub Plug
7-115	145600	Drive-in Stud, 5/8" Diameter
33-52-1	142800	Wheel Retaining Ring
6-109	141000	5/8" Cone Wheel Nut



## 8 Bolt, 6.5" Bolt Circle

- Oil Bath Hub, 3984 Inner / 28682 Outer Bearing
- Capacity of 6,000 lbs. per each
- Fits Dexter 12K Disc Brake, Hi-Profile Axles (16" & 16.5" diameter wheels)
- Rotor available with ABS exciter ring installed

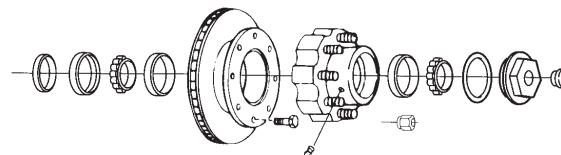

Part No.	Ref. No.	Description
8-214-10UC1	113020	Complete Hub Assembly (Does not include Rotor)
8-214-10	113010	Hub Only
70-006	124950	Brake Rotor Only, Non-ABS
70-006-2	124955	Brake Rotor Only, with ABS exciter ring
25-14	150825	Rotor Mounting Bolt
6-46	193000	Rotor Mounting Nut
3984	131800	Inner Bearing
28682	132000	Outer Bearing
3920	138000	Inner Race
28622	137800	Outer Race
10-56	162000	Unitized Oil Seal, (4.50" O.D., 3.125" I.D.)
21-36	153975	Oil Cap Only, 4.00" O.D., Screw-in, Plastic
10-50	156800	O-Ring Gasket for 21-36
46-32	155600	Oil Cap Plug
46-52	156000	Oil Hub Plug
7-115	145600	Drive-in Stud, 5/8" Diameter
33-52-1	142800	Wheel Retaining Ring
6-109	141000	5/8" Cone Wheel Nut



## 10 Bolt, 8.75" Bolt Circle (Dual Wheel)

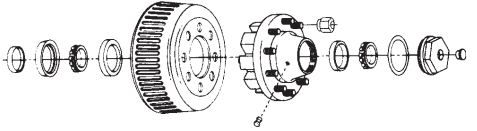

- Oil Bath Hub, 3984 Inner / 28682 Outer Bearing
- Capacity of 7,500 lbs. per each
- Fits Dexter 15K Axles
- Drum Size: 12 1/4" x 5"
- Drum available with ABS exciter ring installed

Part No.	Ref. No.	Description
8-217-5UC1	113400	Complete Hub Assembly ,RH (Does not include Brake Drum)
8-217-25UC1	113800	Complete Hub Assembly ,LH (Does not include Brake Drum)
8-217-5	113200	Hub Only, RH
8-217-25	113600	Hub Only, LH
9-28-1	124600	Brake Drum Only, Non-ABS
9-28-5	124605	Brake Drum Only, with ABS exciter ring
7-103	150600	Drum Mounting Bolt
3984	131800	Inner Bearing
28682	132000	Outer Bearing
3920	138000	Inner Race
28622	137800	Outer Race
10-56	162000	Unitized Oil Seal, (4.50" O.D., 3.125" I.D.)
21-36	153975	Oil Cap Only, 4.00" O.D., Screw-in, Plastic
10-50	156800	O-Ring Gasket for 21-36
46-32	155600	Oil Cap Plug
46-52	156000	Oil Hub Plug
25-13-1	149000	Screw-in Stud, RH
25-13-2	149200	Screw-in Stud, LH
6-69-1	142000	13/16" RH Inner Wheel Nut
6-69-2	142200	13/16" LH Inner Wheel Nut
6-70-1	142400	1 1/2" RH Outer Wheel Nut
6-70-2	142600	1 1/2" LH Outer Wheel Nut



## Nev-R-Lube

No need to pull the hubs to repack the bearings!  
No need to replace seals when you check the brakes!  
No more inner and outer bearings!

### Pre-set Adjustments.

Ease of installation. Human error is virtually eliminated in bearing adjustment.

### Pre-Lubricated at the Bearing Factory.

Resistant to contamination.

### Sealed for Life.

No bearing maintenance. Increased durability and reliability.

### Lower maintenance cost.

5-year or 100,000 miles warranty against defects in material or workmanship.

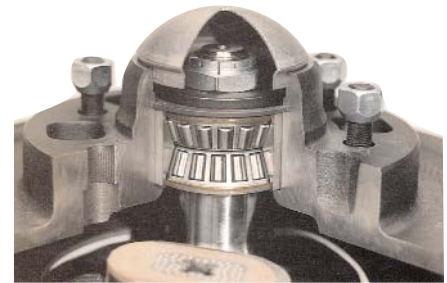

Available in 35mm cartridge, 42mm cartridge and 50mm cartridge.  
See pages A8 thru A17 and A32 thru A40 for specific application.

## Nev-R-Lube 6 Bolt, 5.5" Bolt Circle



- Fits Dexter 35MM Nev-R-Lube Axle
- Capacity of 1,750 lbs. per each
- Drum size: 10" x 2 1/4"

Part No.	Ref No.	Description
8-386-5UC3	118275	Complete Hub and Drum Assembly
8-386-5	118250	Hub and Drum Only
31-72-3	130885	Cartridge Bearing, 35MM x 64MM x 37MM
69-94	167845	Snap Ring, Inner Bearing Retainer, 2.51" O.D.
38605	152200	Grease Cap, 2.75" OD, Drive-In
7-122	144600	Drive-in Stud, 1/2" Diameter
X1023R	140600	1/2" Cone Wheel Nut

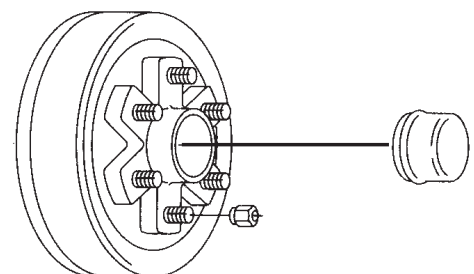

### Nev-R-Lube 6 Bolt 5.5" Bolt Circle

- Fits Dexter 42MM Nev-R-Lube Axle
- Capacity of 3,000 lbs. per each
- Drum size: 12"x2"

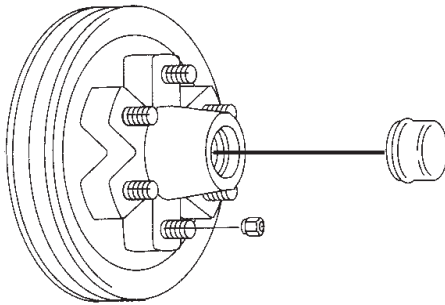

Part No.	Ref No.	Description
8-388-5UC3	119525	Complete Hub and Drum Assembly
8-388-5	119500	Hub and Drum Only
31-73-3	130900	Cartridge Bearing, 42MM x 76MM x 39MM
69-95	167850	Snap Ring, Inner Bearing Retainer, 3" OD
1609	152600	Grease Cap, 3.125" OD, Drive-In
7-122	144600	Drive-in Stud, 1/2" Diameter
X1023R	140600	1/2" Cone Wheel Nut

### Nev-R-Lube 8 Bolt 6.5" Bolt Circle

- Fits Dexter 50MM Nev-R-Lube Axle
- Capacity of 3,500 lbs. per each
- Drum size: 12"x2"

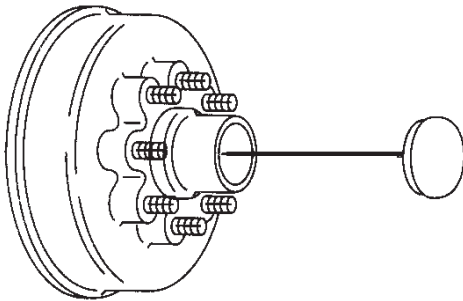

Part No.	Ref No.	Description
8-385-4UC3	119575	Complete Hub and Drum Assembly
8-385-4	119550	Hub and Drum Only
31-71-3	130875	Cartridge Bearing, 50MM x 84MM x 54MM
69-93	167840	Snap Ring, Inner Bearing Retainer, 3.35" OD
75DC	153000	Grease Cap, 3.355" OD, Drive-In
7-122	144600	Drive-in Stud, 1/2" Diameter
X1023R	140600	1/2" Cone Wheel Nut

### Nev-R-Lube 8 Bolt 6.5" Bolt Circle

- Fits Dexter 50MM Nev-R-Lube Axle
- Capacity of 4,000 lbs. per each
- Drum size: 12 1/4" x 3 3/8"

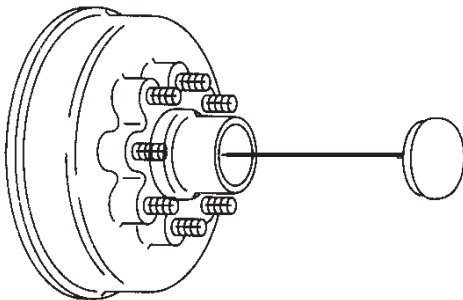

Part No.	Ref No.	Description
8-389-11UC3	123180	Complete Hub and Drum Assembly
8-389-11	123175	Hub and Drum Only
31-71-3	130875	Cartridge Bearing, 50MM x 84MM x 54MM
69-93	167840	Snap Ring, Inner Bearing Retainer, 3.35" OD
75DC	153000	Grease Cap, 3.355" OD, Drive-In
7-132	145200	Drive-in Stud, 9/16" Diameter
6-53	140800	9/16" Cone Wheel Nut

## Wheel Bearing Kits

Makes Bearing Replacements Easier and Quicker!  
One Kit Per Wheel Required!

Wheel Bearing Kits are available for:

- Applications ranging from the BT8 1" spindle to the 7,000 lb. spindles
- Double Lip Grease Seals are used, allowing kits to be used with standard or E-Z Lube Spindles.

Each Wheel Bearing Kit includes:

- One Inner Bearing and Race
- One Outer Bearing and Race
- Grease Seal
- Cotter Pin



AXLE  
COMPONENTS

Part No.	Ref. No.	Outer Bearing	Inner Bearing	Seal	Seal I.D.
BK1-100	128611	L44643	L44643	34823*	1.249"
BK1-150	128621	L44649	L44649	10-60	1.500"
BK2-100	128641	L44649	L68149	10-19	1.719"
BK3-100	128662	15123	25580	10-36	2.250"
BK3-110	128664	15123	25580	10-10	2.125"
BK3-200	128684	14125A	25580	10-36	2.250"
BK3-210	128686	14125A	25580	10-10	2.125"
BK3-300	128704	LM67048	25580	10-36	2.250"
BK3-310	128706	LM67048	25580	10-10	2.125"

\* Single Lip Seal

## Packaged Grease Caps

Protect bearings from contamination with packaged grease caps.



Part No.	Ref. No.	Description
RG04-010	150900	PLUG ONLY FOR EZ LUBE GREASE CAPS
RG04-020	150905	1.986" O.D., DRIVE IN
RG04-040	150910	1.986" O.D., DRIVE IN W/PLUG FOR EZ LUBE
RG04-060	150915	2.44" E.D., DRIVE IN
RG04-080	150920	2.44" O.D., DRIVE IN W/PLUG FOR EZ LUBE
RG04-100	150925	2.75" DRIVE IN
RG04-120	150930	2.72" DRIVE IN W/PLUG FOR EZ LUBE



**Grease Seals**

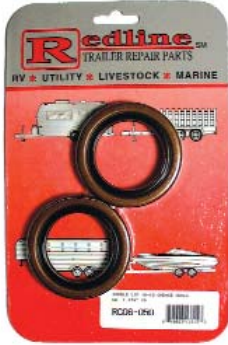

Packaged double lip seals provide extra protection and longer life than standard single lip seals. Two per package.

RG06-010	157700	34823*	1.249"	N/A
RG06-020	157710	10-60	1.987"	10-9
RG06-050	157720	10-19	1.719"	58846
RG06-070	157730	10-36	2.25"	42385
RG06-090	157740	10-10	2.125"	10-1

\*Single Lip Seal

**Replacement Hub Assemblies**



Each Kit Contains:

- Hub with pressed in Race and Studs
- Bearings
- Grease Cap
- Grease Seal

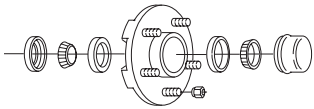

Part No.	Ref. No.	Bolt Pattern	Outer Bearing	Inner Bearing	Seal	Fits Spindle
34822BX	105410	4 on 4"	L44643	L44643	34823	BT8
34822545BX	106210	5 on 4.5"	L44643	L44643	34823	BT8
84545BX	107010	5 on 4.5"	L44649	L68149	58846	#84
84550BX	107810	5 on 5"	L44649	L68149	58846	#84

**Running Gear Replacement Parts**

The Most Commonly Asked For Running Gear Parts  
in Attractive Showroom Packaging!

Designed for  
Your Retail Sales...

Convenient Redline assortments simplify product selection and display set up in your retail showroom. Each assortment includes a selection of the best selling products in each category, a shelf header card and a plan-o-gram to help with product placement.

A variety of assortments are available for most popular trailer repair parts and towing accessories.

*Packaged Assortment  
Program Available!*

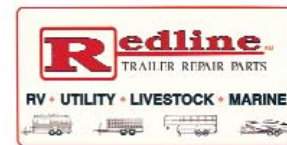

*Call Your Nearest Branch For Details!*

### Packaged Rim Clamps and Wheel Nuts

Part No.	Ref. No.	Description
RG01-020	139900	RIM CLAM FOR MOBILE HOME & UTILITY 14.5" RIMS,(QTY 5)
RG01-040	139910	9/16"X 7/8" HEX WHEEL NUT RH THREAD (QTY 5)
RG01-060	139920	1/2"X13/16" CONE WHEEL NUT RH THREAD, 60 DEGREE CONED, (QTY 5)
RG01-080	139930	9/16"X 7/8" CONE WHEEL NUT RH THREAD, 60 DEGREE CONED, (QTY 4)
RG01-100	139940	5/8"X1-1/16" CONE WHEEL NUT RH THREAD, 90 DEGREE CONED, (QTY 4)
RG01-120	139950	5/8"X1-1/8" FLANGED WHL NUT, RH THREAD (QTY 4)
RG01-150	139980	1/2" WHEEL LOCK SET, INCLUDES 2 LOCKS & 1 KEY

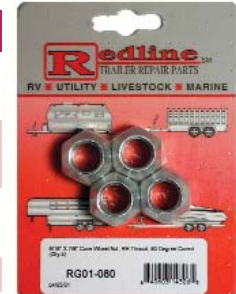

AXLE  
COMPONENTS

### Packaged Wheel Bolts

Part No.	Ref. No.	Description
RG02-020	142900	WHEEL BOLT, 1/2" DIAMETER, 13/16" HEAD, 1" LONG, 60 DEGREE, (QTY 4)
RG02-040	142910	WHEEL BOLT, 1/2" DIAMETER, 13/16" HEAD, 7/8" LONG, 90 DEGREE, (QTY 4)
RG02-060	142920	WHEEL BOLT, 9/16" DIAMETER, 7/8" HEAD, 1-1/8" LONG, 90 DEGREE, (QTY 4)



### Packaged Wheel Studs

Part No.	Ref. No.	Description
RG03-020	144100	DRIVE-IN STUD, 1/2" DIAMETER, 1-1/2" LONG (QTY 4)
RG03-040	144110	DRIVE-IN STUD, 1/2" DIAMETER, 1-13/16" LONG (QTY 4)
RG03-060	144120	DRIVE-IN STUD, 1/2" DIAMETER, 1-7/8" LONG (QTY 4)
RG03-080	144130	DRIVE-IN STUD, 1/2" DIAMETER, 2-1/2" LONG (QTY 4)
RG03-120	144140	DRIVE-IN STUD, 5/8" DIAMETER, 3-1/8" LONG (QTY 4)
RG03-140	144150	DRIVE-IN STUD, 5/8" DIAMETER, 2-13/16" LONG (QTY 4)



### Packaged Spindle Nut Kits

Part No.	Ref. No.	Description
RG05-020	163100	1"-14 SPINDLE NUT, PKG 2EA, W /TONGUE WASHER & COTTER PIN
RG05-040	163110	1"-14 SPINDLE NUT, PKG 2EA, W/ D-WASHER & COTTER PIN
RG05-060	163120	1"-14 SPINDLE NUT, PKG 2EA, W/ TANG & D-WASHER, E-Z LUBE

See Pages B-39 thru B-40 for unpackaged items.

## Replacement Bearings

Replacement Bearings are high quality tapered roller bearings, designed for high-speed use. All bearings have industry standard numbers, regardless of the brand. Inner dimension of bearing is included for your convenience.



Part No.	Ref. No.	Description	I.D.
L44643	128800	INNER / OUTER FOR BT8	1.000
L44649	129000	INNER / OUTER FOR BTR, OUTER FOR #84 SPINDLES	1.063
L68149	129200	INNER FOR #84 SPINDLES	1.378
1779	129400	OUTER FOR 22834 HUB	0.938
2788	129600	INNER FOR 22834 HUB	1.500
LM48548	129800	INNER FOR AH25555F AGRICULTURAL HUB	1.375
LM67048	130000	OUTER FOR 8-201-5, 8-213-5	1.250
15123	130400	OUTER FOR 42655, 42656, 8-174-5	1.250
14125A	130600	OUTER FOR 42865, 42866, 8-219-4, 8-231-9	1.250
25580	130800	#42, 8K, 9K INNER (PRE 10/89), OUTER FOR #99	1.750
31-71-3	130875	50MM CARTRIDGE STYLE, NEV-R-LUBE	50MM
31-72-3	130875	35MM CARTRIDGE STYLE, NEV-R-LUBE	35MM
31-73-3	130900	42MM CARTRIDGE STYLE, NEV-R-LUBE	42MM
02475	131000	OUTER FOR 8-231-8, 8-218-9, 8-187-7	1.250
2585	131200	OUTER FOR 8-232-5	1.313
387A	131400	OUTER FOR 8-214-5, INNER FOR 8-260-5	2.250
395S	131600	INNER FOR 8-214-5	2.625
3984	131800	INNER FOR 8-216-5, 8-214-8, 8-217-5, 8-272-5	2.625
28682	132000	OUTER FOR 8-216-5, 8-214-8, 8-217-5, 8-727-5	2.250
28580	132200	INNER FOR ALL #99 SPINDLES	2.000
JM205149	132600	FOR 090814 HAYES 10K	1.969
JM511946	132800	FOR 090814 HAYES 10K	2.559
HM212049	133000	OUTER FOR 20K - 25K AXLES	2.625
HM218248	133100	INNER FOR 20K - 25K AXLES	3.542
LM11949	133200	OUTER FOR AH15450E AGRICULTURAL HUB	0.750
29749	133600	FOR AH30660F AGRICULTURAL HUB	1.500
501349	133800	OUTER FOR AH60880F, INNER FOR AH35660F	1.625
506849	134000	FOR AH60880F AGRICULTURAL HUB	2.165
603049	134200	FOR AH45880F AGRICULTURAL HUB	1.781

## Bearing Protectors



Bearing Protectors keep grease inside the hub and water out! An overload outlet allows grease to escape if the hub is overfilled or excessive pressure is built up. Outer diameter is 1.980, fits hubs with L44610 outer race. Chrome plated metal alloy construction. The Bearing Protector Bra, #BLB1, keeps the excess grease from being thrown on the wheels while trailering.

Part No.	Ref. No.	Description
BL1980	413800	ONE EACH, CHROME-PLATED METAL BEARING PROTECTOR
BLB1	414000	ONE EACH, BEARING PROTECTOR BRA, USE WITH ABOVE



## Replacement Races

Part No.	Ref. No.	Description	O.D.
L44610	134400	FOR L44643, L44649 BEARING	1.980
1729	134600	FOR 1779 BEARING	2.240
2729	134800	FOR 2788 BEARING	3.000
L68111	135000	FOR L68149 BEARING	2.362
LM48510	135200	FOR LM48548 BEARING	2.563
LM67010	135400	FOR LM67048 BEARING	2.328
15245	135600	FOR 15123 BEARING	2.441
14276	135800	FOR 14125A BEARING	2.717
25520	136200	FOR 25580 BEARING	3.265
28521	136800	FOR 28580 BEARING	2.875
02420	137000	FOR 02475 BEARING	2.688
2520	137200	FOR 2585 BEARING	2.750
382A	137400	FOR 287A BEARING	3.813
394A	137600	FOR 395S BEARING	4.331
28622	137800	FOR 28682 BEARING	3.844
3920	138000	FOR 3984 BEARING	4.438
JM205110	138200	FOR JM205149 BEARING	3.543
JM511910	138400	FOR JM511946 BEARING	4.331
HM212011	138600	FOR HM212049 BEARING	4.813
HM218210	138800	FOR HM218248 BEARING	5.786
LM11910	139000	FOR LM11949 BEARING	1.781
29710	139200	FOR 29749 BEARING	2.563
501310	139400	FOR 501349 BEARING	2.891
506810	139600	FOR 506849 BEARING	3.543
603011	139800	FOR 603049 BEARING	3.063



## Grease Caps

Part No.	Ref. No.	Description	O.D.
1527	151000	DRIVE-IN FOR AGRICULTURAL HUBS	1.957
46749	151200	DRIVE-IN FOR 2,000 AND 3,500 LB. AXLES	1.986
21-3-1	151400	DRIVE-IN FOR E-Z LUBE 2,000 AND 3,500 LB. AXLES	1.986
45896	151600	DRIVE-IN FOR 5,200 LB AXLES WITH 6 BOLT HUBS	2.440
21-1-1	151800	DRIVE-IN FOR E-Z LUBE	2.440
1604	152000	DRIVE-IN FOR AGRICULTURAL HUBS	2.440
38605	152200	DRIVE-IN FOR 5,200, 6,000 AND 7,000 LB AXLES	2.750
21-43-1	152400	DRIVE-IN FOR E-Z LUBE	2.720
1609	152600	DRIVE-IN FOR AGRICULTURAL HUBS	3.125
1602	152800	DRIVE-IN FOR VILLAGE 7,000 LB AXLES	3.250
75DC	153000	DRIVE-IN FOR #99 SPINDLES	3.355
092105	153200	DRIVE-IN FOR HAYES 10,000 AND 12,000 LB AXLES	3.625



## Bolt-On Oil Caps

Part No.	Ref. No.	Description
340-4139	157400	OIL CAP, 6 ON 4.06" BOLT, FOR HAYES 10K
340-4009	157600	OIL CAP, 6 ON 5 1/2" BOLT, FOR 20K - 25K AXLES



## Complete Screw-On Oil Cap Kits



Part No.	Ref. No.	Description	Fits:
22-03	154800	21-35 OIL CAP, 10-45 O-RING, 46-32 PLUG	6K, 7K, 8K, 9K AXLES (8 BOLT) DEXTER
22-05	155200	92125 OIL CAP, 92127 O-RING, 92126 PLUG	10K, 12K HAYES / ALKO
22-06	155300	21-40 OIL CAP, 10-59 O-RING	6K, 7K, OIL BATH HUB AND DRUMS (5 SPOKE)
22-07	155310	21-36 OIL CAP, 10-50 O-RING, 46-32 PLUG	9K (AFTER 10/89) AND 10K GENERAL DUTY
22-08	155320	92128 OIL CAP, 92130 O-RING, 92126 PLUG	8K HAYES / ALKO (AFTER 01/97)
22-09	155330	9212801 OIL CAP, 92130 O-RING, 92126 PLUG	8K HAYES / ALKO (PRIOR 01/97)

## Grease Seals, Oil Seals and Wear Sleeves

Standard are single lip. E-Z Lube & oil seals are double lip or unitized.



Part No.	Ref. No.	Description	I.D.	O.D.	Use With:
34823	157800	GREASE SEAL	1.249	1.983	BT8 SPINDLES
13194	157810	GREASE SEAL	1.372	1.983	UNIQUE BT HUBS
10-9	158000	GREASE SEAL	1.500	1.987	BTR SPINDLES
10-60	158200	GREASE SEAL	1.500	1.987	E-Z LUBE 2,000 LB
1105-100-031	158400	GREASE SEAL	1.750	2.356	10" HADCO
10-42	158600	GREASE SEAL	1.750	2.312	DEX 2,800 LB AXLES
168233	158750	GREASE SEAL	1.688	2.332	UNIQUE #84 HUBS
10-40	158775	GREASE SEAL	1.938	2.510	MHU AXLES
58846	158800	GREASE SEAL	1.719	2.565	3,500 LB AXLES
10-19	159000	GREASE SEAL	1.719	2.565	E-Z LUBE 3,500 LB
29031	159200	GREASE SEAL	1.875	3.000	#8 SPINDLE
1105-100-035	159400	GREASE SEAL	2.00	2.875	12" HADCO
21325	159500	GREASE SEAL	2.125	3.269	UNIQUE #42 HUBS
42385	159600	GREASE SEAL	2.250	3.376	#42 SPINDLE
10-36	159700	GREASE SEAL	2.250	3.376	E-Z LUBE END UNITS
10-1	159800	GREASE SEAL	2.125	3.375	DEX 5,200 - 7,000 LB
10-10	160000	GREASE / OIL SEAL	2.125	3.376	E-Z LUBE & OIL 5,200, 6,000 & 7,000 LB AXLES
T51153	160200	GREASE SEAL	2.375	3.623	#99 SPINDLE
SL150	160400	GREASE SEAL	1.500	2.332	AGRICULTURAL HUB
SL175	160600	GREASE SEAL	1.750	2.722	AGRICULTURAL HUB
SL200	160800	GREASE SEAL	2.000	3.066	AGRICULTURAL HUB
SL226	161000	GREASE SEAL	2.250	3.066	AGRICULTURAL HUB
SL275	161200	GREASE SEAL	2.750	3.756	AGRICULTURAL HUB
10-63	161225	UNITIZED OIL SEAL	2.250	3.376	DEX 8K (&9K 'TIL 10/89)
9103309	161227	OIL SEAL	2.250	3.376	8K HAYES
10-48	161230	OIL SEAL	2.375	3.376	60-6 WEAR SLEEVE
60-6	161235	OIL WEAR SLEEVE	2.250	2.375	10-48 OIL SEAL
10-51	161650	UNITIZED OIL SEAL	2.875	3.880	DEX 9K, 10K G.D.
10-56	162000	OIL SEAL	3.125	4.500	DEX 10K, 12K, 15K & HAYES 10K - 12K
382-8005	162410	OIL SEAL W/ SLEEVE	2.775	3.671	INCLUDES 2.671 I.D. WEAR SLEEVE
10-55-1	162800	OIL SEAL	4.625	6.000	20K - 25K AXLES
91030	163000	OIL SEAL	2.750	3.779	HAYES #99 SPINDLE

## Grease and Oil Cap Replacement Parts

Part No.	Ref No.	Description	For:
21-40	153600	2.563" O.D., SCREW-IN PLASTIC	6K, 7K OIL (5 SPOKE) DX
21-35	153800	2.875" O.D., SCREW-IN PLASTIC	6K – 8K (& 9K PRIOR 10/89) DX
21-36	153975	4.00" O.D., SCREW IN PLASTIC	9K (AFTER 10/89), 10K GD, 10K – 15K DX
92128	154100	OIL CAP ONLY	7K-8K HAYES/ALKO NEW STYLE (AFTER 01/97)
9212801	154150	OIL CAP ONLY	7K-8K HAYES (PRIOR TO 01/97)
92125	154200	3.750" O.D., SCREW-IN	10K, 12K HAYES / ALKO
85-1	155400	GREASE CAP PLUG, FOR E-Z LUBE GREASE CAPS	ALL E-Z GREASE CAPS
46-32	155600	OIL CAP PLUG	21-35, 21-36, 21-37 CAPS
92126	155800	OIL CAP PLUG	92125, 340-4009, 340-4139, 92128
46-52	156000	OIL HUB PLUG	8K – 15K DEXTER OIL HUBS
10-45	156600	OIL CAP O-RING	21-35 OIL CAP
10-50	156800	OIL CAP O-RING	21-36 CAP
10-59	156825	OIL CAP O-RING	21-40 OIL CAP
92130	156850	OIL CAP O-RING	7K – 8K HAYES
92127	157000	OIL CAP O-RING	92125 OIL CAP



See pg B-39 for Grease Caps



See pg B-39 for Bolt-on Oil Caps

## Rim Clamps

Part No.	Ref. No.	Description	Use With:
15-2	149600	RIM CLAMP, UTG & MH STYLE	14.5" SINGLE RIMS
15-13-1	149800	DOUBLE STYLE RIM CLAMP	15", 17.5" DUAL RIMS
15-15-1	150000	RIM CLAMP	15", 17.5", 20", 22.5" DUAL RIMS



## Wheel Nuts

Part No.	Ref. No.	Description	O.D.
916N	078400	9/16" HEXNUT RH, USE W/15-2 CLAMP	7/8"
STN569	140200	9/16" HEX WHEEL RH, 90 DEGREE CONED	1"
6-117	140450	3/4" HEX RIM NUT RH, USE W/ 15-13-1 OR 15-15-1 CLAMP	1-1/4"
N10R	140500	7/16" CONE WHEEL NUT RH, 60 DEGREE CONED	3/4"
X1023R	140600	1/2" CONE WHEEL NUT RH, 60 DEGREE CONED	13/16"
6-53	140800	9/16" CONE WHEEL NUT RH, 60 DEGREE CONED	7/16"
6-109	141000	5/8" CONE WHEEL NUT RH, 90 DEGREE CONED	1-1/16"
X1148	141200	5/8" CONE WHEEL NUT RH, 90 DEGREE CONED	15/16"
X1149	141400	5/8" CONE WHEEL NUT LH, 90 DEGREE CONED	15/16"
95188	141600	5/8" FLANGED WHEEL NUT RH	1-1/8"
6-69-1	142000	WHEEL NUT, RH INNER BUDD TYPE	1-3/16"
6-69-2	142200	WHEEL NUT, LH INNER BUDD TYPE	1-3/16"
6-70-1	142400	WHEEL NUT, RH OUTER BUDD TYPE	1-1/2"
6-70-2	142600	WHEEL NUT, LH OUTER BUDD TYPE	1-1/2"
33-52-1	142800	WHL RETAINING RING 9K-12K USE W/6-109 NUTS	N/A



## Wheel Bolts

Use the following table to choose the correct wheel bolt. Dimensions are as follows:  
A=Thread Diameter, B=Thread Length, C= Head Size.

AXLE  
COMPONENTS

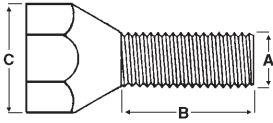

Part No.	Ref. No.	A	B	C	Description
X1064	143200	1/2"	7/8"	1 3/16"	FINE THREAD, 60 DEGREE CONED
LB509	143300	1/2"	7/8"	1 3/16"	FINE THREAD, 90 DEGREE CONED
LB569	143400	9/16"	1 1/8"	7/8"	FINE THREAD, 90 DEGREE CONED
090753	143600	1/2"	1 5/8"	7/8"	COARSE THREAD, FLAT HEAD
090702	143800	1/2"	1 7/8"	7/8"	FINE THREAD, FLAT HEAD
7-23	144000	1/2"	2 1/4"	7/8"	COARSE THREAD, FLAT HEAD

## Wheel Studs - Screw In

Screw-in studs are threaded on both ends. Dimensions are as follows:  
A=Thread Diameter, B= Overall Length, C=Lug Nut End Length, D= Hub End Length.

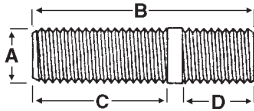

Part No.	Ref. No.	A	B	C	D
25-53	147800	1/2"	2"	1 1/6" FINE	1 3/16" FINE
25-51	148000	1/2"	2"	7/8" FINE	5/8" COARSE
25-11	148200	9/16"	3"	1 9/16" FINE	3/4" COARSE
25-48	148800	5/8"	3"	1 9/16" FINE	1" COARSE
25-13-1	149000	3/4"	2 1/2" RH	1" FINE	1 1/4" COARSE
25-13-2	149200	3/4"	2 1/2" LH	1" FINE	1 1/4" COARSE
25-55	149400	3/4"	3"	1" COARSE	1 3/4" COARSE

## Wheel Studs - Drive In

Dimensions are as follows:  
A=Thread Diameter, B=Stud Length, C=Spline Length, D=Base Length, E= Spline Diameter.

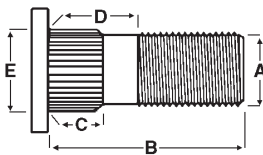

Part No.	Ref. No.	A	B	C	D	E
165981	144400	1/2"	1 1/2"	.25	.45	.62
7-122	144600	1/2"	1 13/16"	.62	.73	.61
09251510	144750	1/2"	1 7/8"	.26	.52	.54
166013	144900	1/2"	2 3/8"	.65	.85	.61
165995	145000	1/2"	2 1/2"	.68	1.38	.54
7-223	145300	9/16"	2"	.58	.75	.69
7-132	145200	9/16"	2 5/16"	.83	1.03	.69
1660151	146000	5/8" RH	2 3/4"	.79	.97	.65
090737	145800	5/8"	2 13/16"	.58	.80	.68
7-224	145350	5/8"	2 1/2"	.71	1.15	.69
7-115	145600	5/8"	3 1/8"	1.02	1.39	.69
9251513	146400	5/8"	3 1/4"	.58	1.45	.66
7-232	145400	5/8"	2 3/4"	.83	1.03	.69



## Brake Assemblies

Electric Brake Assemblies Tables	C-3 - C-8
Dexter 7" x 1 1/4" Electric	C-9
Dexter 10" x 1 1/2" Electric	C-9
Hayes 10" x 2 1/4" Electric	C-10
Dexter 10" x 2 1/4" Electric	C-10
Dexter 12" x 2"	C-11
Dexter 12" x 2" Mobile Home Electric	C-11
Foreman 12" x 2" Electric	C-12
Hayes 12" x 2" Electric	C-12
Dexter 12" x 3" Electric	C-13
Fayette 12" x 2" Electric	C-13
Dexter 12 1/4" x 2 1/2" Electric	C-14
Hayes 12" x 3 1/4" Electric	C-14
Dexter 12 1/4" x 3 3/8" Electric	C-15 - C-16
Warner 12 1/4" x 3 1/2" Electric	C-17
Hayes 12 1/4" x 3 1/2" Electric	C-17
Dexter 12 1/4" x 4" Electric	C-18
Dexter 12 1/4" x 5" Electric	C-19
Atwood 7" x 1 3/4" Hydraulic	C-25
Dexter 7" x 1 3/4" Hydraulic Brake Assembly	C-25
10" x 2 1/4" Hydraulic	C-26
12" x 2" Single-Servo Hydraulic	C-27
12" x 2" Duo-Servo Hydraulic	C-28
Bendix 12" x 3" Duo-Servo Hydraulic	C-28
Hayes 12" x 3 1/4" Duo-Servo Hydraulic	C-29
Dexter 12 1/4" x 3 3/8" Duo-Servo Hydraulic	C-29 - C-30
Hayes 12 1/4" x 3 1/2" Duo-Servo Hydraulic	C-30
Dexter 12 1/4" x 4" Duo-Servo Hydraulic	C-31
Dexter 12 1/4" x 5" Duo-Servo Hydraulic	C-32
Replacement Parts for Hayes 10K and 12K Hydraulic Disc Brakes	C-33
Replacement Parts for Dexter 10K and 12K Hydraulic Disc Brakes	C-33
Miscellaneous Air Brake Replacement Parts for Dexter Air Brakes	C-34

## How to Select Electric Brakes & Brake Parts

### A Few Things To Keep In Mind:

1. To determine the right or left side brake assembly, position the brake with the **magnet at the bottom**. On electric brakes, the actuating arm will always curve from the pivot pin to the magnet, toward the left for left hand brakes and toward the right for right hand brakes. (See the illustration.)
2. When ordering your brake assembly or brake replacement part, always **use both the part number and the reference number**. Both are necessary to insure prompt and correct filling of your order.
3. Sometimes the easiest, most economical way to repair a brake is to replace the complete assembly. By removing wires and a few nuts and bolts, you have **all new parts**, saving time, trouble and expense.
4. Whether you choose to replace the entire brake assembly, only individual parts in need of repair, or need new brakes to build a trailer--**We have what you need** to do the job right! We are just a telephone call away.

### Selecting Electric Brake Parts:

1. Determine the size of your brake.
  - A. Measure the diameter of the mounted brake shoe.
  - B. Measure the width of the lining
2. Determine the manufacturer of your brake.
  - A. Select the brake you have by looking at the key identification points shown in the drawing.
  - B. Check the electric brake chart for your brake and the part you need. Further identification may be made by referring to the exploded drawings and magnet photos of each brake.
3. Select the part you need. Though many parts are shown, we carry only the replacement parts numbered. The words "Parts Only" indicate that complete brake assemblies are not available.

### Using The Electric Brake Chart:

1. Find the picture that matches the assembly or the part you need.
2. The part and reference numbers are just below the picture of your assembly or part. Part and reference numbers are placed beside the photo of individual replacement parts. Use them to order what you need.
3. Double check your part against its listing in the pages which show the exploded drawings, assembly and magnet photographs.
4. Call or fax your order to our location nearest you.

### Reasons Why Brake Hardware Should Be Replaced:

1. Worn, weak return springs will cause the brake linings to drag against the drum and cause premature brake failure.
2. Hold-down springs will lose their tension and allow the brake shoes to wobble or ride up against the face of the brake drum, causing premature lining failure.
3. A frozen adjusting screw will not allow shoes to be adjusted properly.
4. Rubber dust plugs will crack with age and allow dirt to contaminate linings. (Not shown.)
5. A stretched self-adjusting cable prevents the self-adjusting lever from properly aligning the shoes. (Not shown or illustrated.)

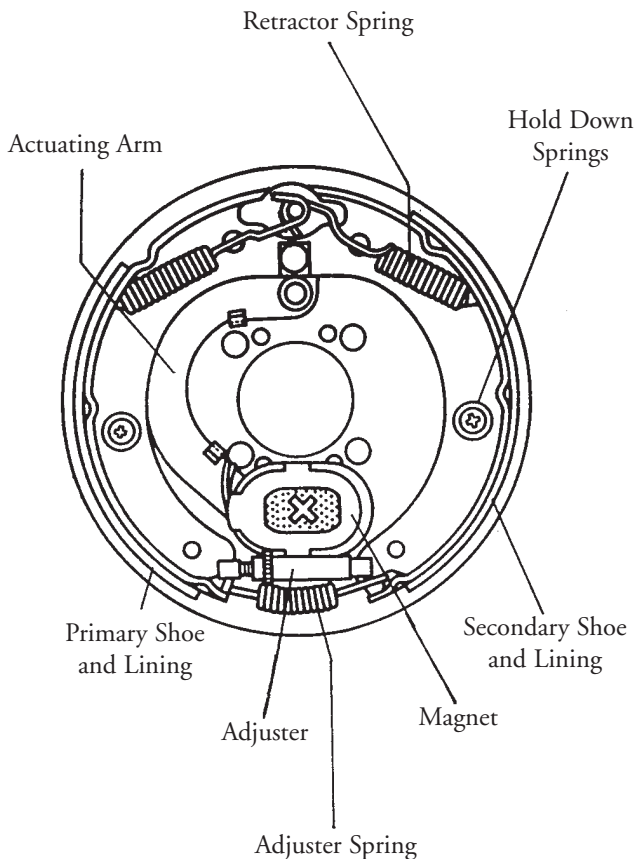

**Complete Brake Assemblies**

				
Manufacturer	7" x 1 1/4" Dexter	10" x 1 1/2" Dexter	10" x 2 1/4" Dexter	10" x 2 1/4" Hayes (New)
Capacity Per Pair	2,000 lbs	2,800 lbs	3,500 lbs	3,500 lbs
Left Hand Part No.	23-47	Parts Only	23-26	60202803
Left Hand Ref. No.	180800		181600	182300
Right Hand Part No.	23-48	Parts Only	23-27	60202703
Right Hand Ref. No.	181000		181800	182350
Magnet Kit				
			Green Wire	
Part Number	BP01-068	BP01-064	BP01-115	BP01-110
Ref. Number	193580	193510	194050	194000
Brake Featured on	Page C-9	Page C-9	Page C-10	Page C-10

BRAKE  
ASSEMBLIES



**ELECTRIC BRAKE PARTS REPLACEMENT CHART**

Actuating Arm L.H.		Part No. BP02-015 Ref. No. 197800	Part No. BP02-050 Ref. No. 198410	Part No. BP02-170 Ref. No. 198800	Part No. BP02-130 Ref. No. 199250
Actuating Arm R.H.		Part No. BP02-025 Ref. No. 198000	Part No. BP02-055 Ref. No. 198420	Part No. BP02-180 Ref. No. 200000	Part No. BP02-140 Ref. No. 199300
Shoe Lining L.H.		Part No. BP04-040 Ref. No. 204600	Part No. BP04-065 Ref. No. 204850	Part No. BP04-090 Ref. No. 205200	Part No. BP04-100 Ref. No. 205400
Shoe Lining R.H.		Same As Left Hand	Same As Left Hand	Same As Left Hand	Same As Left Hand
Shoe Hold Down Spring		Part No. BP06-040 Ref. No. 211400	Part No. BP06-055 Ref. No. 211810	Part No. BP06-120 Ref. No. 212500	Part No. BP06-120 Ref. No. 212500
Shoe Return Spring		Part No. BP07-040 Ref. No. 215800	Part No. BP07-085 Ref. No. 216275	Part No. BP07-105 Ref. No. 216625	Part No. BP07-105 Ref. No. 216625
Adjuster Spring		Part No. BP08-040 Ref. No. 219600	Part No. BP08-070 Ref. No. 220000	Part No. BP08-070 Ref. No. 220000	Part No. BP08-070 Ref. No. 220000
Adjuster L.H.		Part No. BP10-040 Ref. No. 222000	Part No. BP10-060 Ref. No. 222400	Part No. BP10-060 Ref. No. 222400	Part No. BP10-060 Ref. No. 222400
Adjuster R.H.		Same As Left Hand	Same As Left Hand	Same As Left Hand	Same As Left Hand
Adjuster Plug		Part No. BP10-220 Ref. No. 225100	Part No. BP10-220 Ref. No. 225100	Part No. BP10-220 Ref. No. 225100	Part No. BP10-220 Ref. No. 225100

## Complete Brake Assemblies



Manufacturer	10" x 2 1/4" Hayes (Old)	12" x 2" Dexter	12" x 2" Foreman	12" x 2" Hayes (Old)
Capacity Per Pair	3,500 lbs	6,000 lbs	5,200 lbs	5,200 lbs
Left Hand Part No.	Parts Only	23-105	Parts Only	Parts Only
Left Hand Ref. No.		182900		
Right Hand Part No.	Parts Only	23-106	Parts Only	Parts Only
Right Hand Ref. No.		183000		
Magnet Kit		 White Wire		
Part Number	BP01-090	BP01-185	N/A	BP01-160
Ref. Number	193800	195050	N/A	194600
Brake Featured on	Page C-10	Page C-11	Page C-12	Page C-12











## ELECTRIC BRAKE PARTS REPLACEMENT CHART

Actuating Arm L.H.		N/A	Part No. BP02-230 Ref. No. 201400	Part No. BP02-230 Ref. No. 201400	N/A
Actuating Arm R.H.		N/A	Part No. BP02-240 Ref. No. 201600	Part No. BP02-240 Ref. No. 201600	N/A
Shoe Lining L.H.		Part No. BP04-100 Ref. No. 205400	Part No. BP04-150 Ref. No. 205950	Part No. BP04-150 Ref. No. 205950	Part No. BP04-185 Ref. No. 206725
Shoe Lining R.H.		Same As Left Hand	Same As Left Hand	Same As Left Hand	Same As Left Hand
Shoe Hold Down Spring		Part No. BP06-120 Ref. No. 212500	Part No. BP06-090 Ref. No. 212400	Part No. BP06-090 Ref. No. 212400	Part No. BP06-090 Ref. No. 212400
Shoe Return Spring		Part No. BP07-105 Ref. No. 216625	Part No. BP07-105 Ref. No. 216625	Part No. BP07-105 Ref. No. 216625	Part No. BP07-105 Ref. No. 216625
Adjuster Spring		Part No. BP08-070 Ref. No. 220000	Part No. BP08-070 Ref. No. 220000	Part No. BP08-070 Ref. No. 220000	Part No. BP08-070 Ref. No. 220000
Adjuster L.H.		Part No. BP10-060 Ref. No. 222400	Part No. BP10-060 Ref. No. 222400	Part No. BP10-060 Ref. No. 222400	Part No. BP10-060 Ref. No. 222400
Adjuster R.H.		Same As Left Hand	Same As Left Hand	Same As Left Hand	Same As Left Hand
Adjuster Plug		Part No. BP10-220 Ref. No. 225100	Part No. BP10-220 Ref. No. 225100	Part No. BP10-220 Ref. No. 225100	Part No. BP10-220 Ref. No. 225100











**Complete Brake Assemblies**

				
Manufacturer	12" x 2" Dexter	12" x 2" Hayes	12" x 3 Dexter	12" x 3 1/4" Hayes
Capacity Per Pair	7,000 lbs	7,000 lbs	7,500 lbs	8,000 lbs
Left Hand Part No.	23-180	60208712	Parts Only	60204403
Left Hand Ref. No.	184400	185100		185600
Right Hand Part No.	23-181	60208713	Parts Only	60204303
Right Hand Ref. No.	184600	185150		185800
Magnet Kit				
Part Number	BP01-225	BP01-180	N/A	BP01-285
Ref. Number	185850	1995000	N/A	197100
Brake Featured on	Page C-11	Page C-12	Page C-13	Page C-14

BRAKE  
ASSEMBLIES







**ELECTRIC BRAKE PARTS REPLACEMENT CHART**

Actuating Arm L.H.		Part No. BP02-230 Ref. No. 201400	Part No. BP02-224 Ref. No. 201225	N/A	Part No. BP02-305 Ref. No. 203050
Actuating Arm R.H.		Part No. BP02-240 Ref. No. 201600	Part No. BP02-228 Ref. No. 201250	N/A	Part No. BP02-303 Ref. No. 203025
Shoe Lining L.H.		Part No. BP04-180 Ref. No. 206700	Part No. BP04-185 Ref. No. 206725	Part No. BP04-200 Ref. No. 206800	Part No. BP04-220 Ref. No. 207800
Shoe Lining R.H.		Same As Left Hand	Same As Left Hand	Same As Left Hand	Same As Left Hand
Shoe Hold Down Spring		Part No. BP06-090 Ref. No. 212400	Part No. BP06-090 Ref. No. 212400	N/A	Part No. BP06-195 Ref. No. 213500
Shoe Return Spring		Part No. BP07-105 Ref. No. 216625	Part No. BP07-150 Ref. No. 217400	N/A	Part No. BP07-200 Ref. No. 218400
Adjuster Spring		Part No. BP08-070 Ref. No. 220000	Part No. BP08-070 Ref. No. 220000	N/A	Part No. BP08-180 Ref. No. 221600
Adjuster L.H.		Part No. BP10-060 Ref. No. 222400	Part No. BP10-060 Ref. No. 222400	Part No. BP10-135 Ref. No. 223700	Part No. BP10-120 Ref. No. 223400
Adjuster R.H.		Same As Left Hand	Same As Left Hand	Same As Left Hand	Same As Left Hand
Adjuster Plug		Part No. BP10-220 Ref. No. 225100	Part No. BP10-220 Ref. No. 225100	N/A	N/A

**Complete Brake Assemblies**

Stamped Backing Plate    Cast Backing Plate    Stamped Backing Plate    Cast Backing Plate









Manufacturer	12 1/4" x 2 1/2"	12 1/4" x 2 1/2"	12 1/4" x 3 3/8"	12 1/4" x 3 3/8"
	Dexter	Dexter	Dexter	Dexter
Capacity Per Pair	7.2 K	7.2 K	8K-9K (Old)	8K-9K
Left Hand Part No.	23-370 *	23-429	Parts Only	23-434
Left Hand Ref. No.	185400	185420		186110
Right Hand Part No.	23-369 *	23-428	Parts Only	23-435
Right Hand Ref. No.	185300	185410		186210
Magnet Kit				
	White Wire	White Wire	White Wire	White Wire
Part Number	BP01-265	BP01-265	BP01-265	BP01-265
Ref. Number	196700	196700	196700	196700
Brake Featured on	Page C-14	Page C-14	Page C-15	Page C-15

\* 9 Bolt Flange - See page C-14 for 4 Bolt Version













**ELECTRIC BRAKE PARTS REPLACEMENT CHART**

Actuating Arm L.H.		Part No. BP02-270 Ref. No. 202400	Part No. BP02-270 Ref. No. 202400	Part No. BP02-315 Ref. No. 203300	Part No. BP02-315 Ref. No. 203300
Actuating Arm R.H.		Part No. BP02-275 Ref. No. 202500	Part No. BP02-275 Ref. No. 202500	Part No. BP02-325 Ref. No. 203500	Part No. BP02-325 Ref. No. 203500
Shoe Lining L.H.		Part No. BP04-235 Ref. No. 208100	Part No. BP04-236 Ref. No. 208110	Part No. BP04-240 Ref. No. 208200	Part No. BP04-245 Ref. No. 208300
Shoe Lining R.H.		Same As Left Hand	Part No. BP04-238 Ref. No. 208120	Part No. BP04-250 Ref. No. 208400	Part No. BP04-255 Ref. No. 208500
Shoe Hold Down Spring		Part No. BP06-240 Ref. No. 212400	Part No. BP06-195 Ref. No. 213500	Part No. BP06-240 Ref. No. 212400	Part No. BP06-240 Ref. No. 212400
Shoe Return Spring		Part No. BP07-190 Ref. No. 218000	Part No. BP07-190 Ref. No. 218000	Part No. BP07-225 Ref. No. 218900	Part No. BP07-225 Ref. No. 218900
Adjuster Spring		Part No. BP08-070 Ref. No. 220000	Part No. BP08-155 Ref. No. 220910	Part No. BP08-150 Ref. No. 220900	Part No. BP08-155 Ref. No. 220910
Adjuster L.H.		Part No. BP10-090 Ref. No. 222900	Part No. BP10-136 Ref. No. 223710	Part No. BP10-135 Ref. No. 223700	Part No. BP10-136 Ref. No. 223710
Adjuster R.H.		Same As Left Hand	Part No. BP10-146 Ref. No. 223910	Part No. BP10-145 Ref. No. 223900	Part No. BP10-146 Ref. No. 223910
Adjuster Plug		N/A	N/A	N/A	N/A

BRAKE ASSEMBLIES









## Complete Brake Assemblies

	Stamped Backing Plate	Cast Backing Plate	Stamped Backing Plate	Stamped Backing Plate	Stamped Backing Plate
					
Manufacturer	12 1/4" X 3 3/8" Dexter	12 1/4" x 3 3/8" Dexter	12 1/4" x 3 1/2" Warner	12 1/4" X 3 1/2" Hayes	12 1/4" x 4" Dexter
Capacity Per Pair	9K, 10K G.D.	9K-10KGD	10K	9K THRU 12K	10K
Left Hand Part No.	Parts Only	23-450	1301-13	10257	Parts Only
Left Hand Ref. No.		186235	186400	186700	
Right Hand Part No.		23-451	1301-12	10259	
Right Hand Ref. No.		186255	186600	186900	
Magnet Kit					
	Yellow Wire	Yellow Wire			Yellow Wire
Part No.	BP01-301	BP01-301	BP01-270	BP01-285	BP01-301
Ref. No.	197410	197410	196800	197100	197410
Brake Featured on	PAGE C-16	PAGE C-16	PAGE C-17	PAGE C-17	PAGE C-18

BRAKE  
ASSEMBLIES



## Electric Brake Parts Replacement Chart

Actuating Arm L.H.		Part No. BP02-315 Ref. No. 293300	Part No. BP02-315 Ref. No. 203300	Part No. BP02-340 Ref. No. 203800	Part No. BP02-305 Ref. No. 203050	Part No. BP02-315 Ref. No. 203300
Actuating Arm R.H.		Part No. BP02-325 Ref. No. 203500	Part No. BP02-325 Ref. No. 203500	Part No. BP02-330 Ref. No. 203600	Part No. BP02-303 Ref. No. 203025	Part No. BP02-325 Ref. No. 203500
Shoe Lining L.H.		Part No. BP04-240 Ref. No. 208200	Part No. BP04-245 Ref. No. 208300	Part No. BP04-280 Ref. No. 209000	Part No. BP04-290 Ref. No. 209200	Part No. BP04-320 Ref. No. 209600
Shoe Lining R.H.		Part No. BP04-250 Ref. No. 208400	Part No. BP04-255 Ref. No. 208500	Same as Left Hand	Same as Left Hand	Part No. BP04-330 Ref. No. 209800
Shoe Hold Down Spring		Part No. BP06-240 Ref. No. 214400	Part No. BP06-240 Ref. No. 214400	Part No. BP06-300 Ref. No. 215600	Part No. BP06-195 Ref. No. 213500	Part No. BP06-240 Ref. No. 214400
Shoe Return Spring		Part No. BP07-225 Ref. No. 218900	Part No. BP07-225 Ref. No. 218900	Part No. BP07-175 Ref. No. 217700	Part No. BP07-200 Ref. No. 218400	Part No. BP07-225 Ref. No. 218900
Adjuster Spring		Part No. BP08-150 Ref. No. 220900	Part No. BP08-155 Ref. No. 220910	Part No. BP08-120 Ref. No. 220400	Part No. BP08-180 Ref. No. 221600	Part No. BP08-150 Ref. No. 220900
Adjuster L.H.		Part No. BP10-135 Ref. No. 223700	Part No. BP10-136 Ref. No. 223710	Part No. BP10-080 Ref. No. 222800	Part No. BP10-120 Ref. No. 223400	Part No. BP10-135 Ref. No. 223700
Adjuster R.H.		Part No. BP10-145 Ref. No. 223900	Part No. BP10-146 Ref. No. 223910	Same as Left Hand	Part No. BP10-110 Ref. No. 223200	Part No. BP10-145 Ref. No. 223900

**Complete Brake Assemblies**

	Cast Backing Plate	Stamped Backing Plate	Cast Backing Plate	Stamped Backing Plate	Cast Backing Plate
--	--------------------	-----------------------	--------------------	-----------------------	--------------------

Manufacturer	12 1/4"x4" Dexter	12 1/4"x5" Dexter	12 1/4" x 5" Dexter	12 1/4" X 5" Dexter	12 1/4"x5" Dexter
Capacity Per Pair	10K	12,000 LBS	12K	15,000 LBS	15K
Left Hand Part No.	23-438	Parts Only	23-442	Parts Only	23-446
Left Hand Ref. No.	188060		188445		188830
Right Hand Part No.	23-439		23-443		23-447
Right Hand Ref. No.	188080		188455		188840
Magnet Kit					
	Yellow Wire	Black Wire	Black Wire	Blue Wire	Blue Wire
Part No.	BP01-301	BP01-306	BP01-306	BP01-311	BP01-311
Ref. No.	197410	197430	197430	197625	197625
Brake Featured on	PAGEC-18	PAGE C-19	PAGE C-19	PAGE C-19	PAGEC-19



**Electric Brake Parts Replacement Chart**

Actuating Arm L.H.		Part No. BP02-315 Ref. No. 203300	Part No. BP02-375 Ref. No. 204215	Part No. BP02-315 Ref. No. 203300	Part No. BP02-375 Ref. No. 204215	Part No. BP02-315 Ref. No. 203300
Actuating Arm R.H.		Part No. BP02-325 Ref. No. 203500	Part No. BP02-380 Ref. No. 204220	Part No. BP02-325 Ref. No. 203500	Part No. BP02-380 Ref. No. 204220	Part No. BP02-325 Ref. No. 203500
Shoe Lining L.H.		Part No. BP04-325 Ref. No. 209610	Part No. BP04-360 Ref. No. 210400	Part No. BP04-365 Ref. No. 210410	Part No. BP04-360 Ref. No. 210400	Part No. BP04-365 Ref. No. 210410
Shoe Lining R.H.		Part No. BP04-335 Ref. No. 209810	Part No. BP04-370 Ref. No. 210600	Part No. BP04-375 Ref. No. 210610	Part No. BP04-370 Ref. No. 210600	Part No. BP04-375 Ref. No. 210610
Shoe Hold Down Spring		Part No. BP06-240 Ref. No. 214400	Part No. BP06-240 Ref. No. 214400	Part No. BP06-240 Ref. No. 214400	Part No. BP06-240 Ref. No. 214400	Part No. BP06-240 Ref. No. 214400
Shoe Return Spring		Part No. BP07-225 Ref. No. 218900	Part No. BP07-225 Ref. No. 218900	Part No. BP07-225 Ref. No. 218900	Part No. BP07-225 Ref. No. 218900	Part No. BP07-225 Ref. No. 218900
Adjuster Spring		Part No. BP08-155 Ref. No. 220910	Part No. BP08-150 Ref. No. 220900	Part No. BP08-155 Ref. No. 220910	Part No. BP08-150 Ref. No. 220900	Part No. BP08-155 Ref. No. 220910
Adjuster L.H.		Part No. BP10-136 Ref. No. 223710	Part No. BP10-135 Ref. No. 223700	Part No. BP10-136 Ref. No. 223710	Part No. BP10-135 Ref. No. 223700	Part No. BP10-136 Ref. No. 223710
Adjuster R.H.		Part No. BP10-146 Ref. No. 223910	Part No. BP10-145 Ref. No. 223900	Part No. BP10-146 Ref. No. 223910	Part No. BP10-145 Ref. No. 223900	Part No. BP10-146 Ref. No. 223910

## Dexter 7" x 1 1/4" Electric

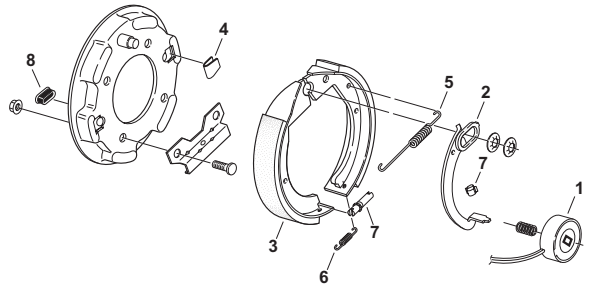

BRAKE  
ASSEMBLIES

### Dexter 7" x 1 1/4" Electric Brake Assemblies

- Capacity: 2,000 lbs. per pair

Part No.	Ref. No.	Description
23-47	180800	LEFT BRAKE (SHOWN IN PHOTO)
23-48	181000	RIGHT BRAKE

### Replacement Parts

Part No.	Ref. No.	Description	Item
BP01-060	193400	MAGNET KIT (OLD STYLE, BEFORE 4/90)	1
BP01-068	193580	MAGNET KIT (NEW STYLE, AFTER 4/90)	1
BP02-015	197800	ACTUATING ARM, LEFT HAND, MUST USE WITH BP01-068	2
BP02-025	198000	ACTUATING ARM, RIGHT HAND, MUST USE WITH BP01-068	2
BP04-040	204600	SHOE AND LINING (ONE WHEEL)	3
BP06-040	211400	SHOE HOLD DOWN SPRING	4
BP07-040	215800	SHOE RETURN SPRING	5
BP08-040	219600	ADJUSTER SPRING	6
BP10-040	222000	ADJUSTER	7
BP10-220	225100	ADJUSTER DUST PLUG, PKG OF 4	8



## Dexter 10" x 1 1/2" Electric

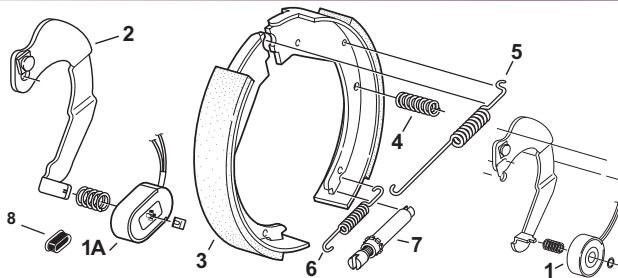

### Replacement Parts

- Since this brake is welded on Dexter's 2.8K axle, only the following replacement parts are available.

- Axles manufactured after 9/99 will accept 10" x 2 1/4" brakes.

PART NO.	REF NO.	DESCRIPTION	ITEM
BP01-068	193580	MAGNET KIT, ROUND	1
BP01-064	193510	MAGNET KIT, OVAL	1A
BP02-050	198410	ACTUATING ARM, LEFT HAND, FOR OVAL MAGNET	2
BP02-055	198420	ACTUATING ARM, RIGHT HAND, FOR OVAL MAGNET	2
BP04-065	204850	SHOE & LINING (ONE WHEEL)	3
BP06-055	211810	SHOE HOLD DOWN SPRINGS	4
BP07-085	216275	SHOE RETURN SPRINGS	5
BP08-070	220000	ADJUSTER SPRINGS	6
BP10-060	222400	ADJUSTER	7
BP10-220	225100	ADJUSTER DUST PLUG, PKG OF 4	8



**Dexter 10" x 2 1/4" Electric**

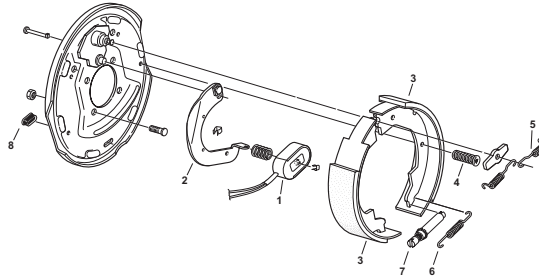

BRAKE ASSEMBLIES



**Dexter 10" x 2 1/4" Electric Brake Assemblies**

- Capacity: 3,500 lbs. per pair

PART NO.	REF NO.	DESCRIPTION
23-26	181600	LEFT BRAKE (SHOWN IN PHOTO)
23-27	181800	RIGHT BRAKE

**Replacement Parts**

PART NO.	REF NO.	DESCRIPTION	ITEM
BP01-110	194000	MAGNET KIT	
BP01-115	194050	MAGNET KIT (GREEN WIRE), GENUINE DEXTER W/PROTECTIVE WIRE SLEEVE	1
BP02-170	199800	ACTUATING ARM, LEFT HAND	2
BP02-180	200000	ACTUATING ARM, RIGHT HAND	2
BP04-090	205200	SHOE & LINING (ONE WHEEL)	3
BP06-120	212500	SHOE HOLD DOWN SPRINGS	4
BP07-105	216625	SHOE RETURN SPRINGS (QTY 2)	5
BP08-070	220000	ADJUSTER SPRINGS	6
BP10-060	222400	ADJUSTER	7
BP10-220	225100	ADJUSTER DUST PLUG, PKG OF 4	8

**Hayes 10" x 2 1/4" Electric**

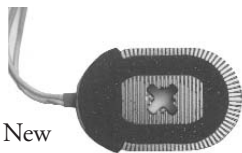
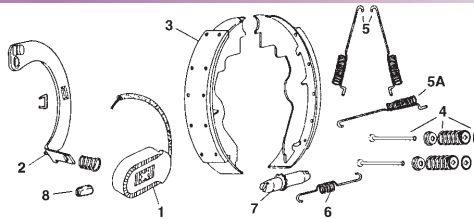

**Hayes 10" x 2 1/4" Electric Brake Assemblies**

- Capacity: 3,500 lbs. per pair
- In late 1987, brake was redesigned to use oval style magnet, replacing round magnet. Old style magnets and replacement parts are available, complete assemblies are not.

PART NO.	REF NO.	DESCRIPTION
60202803	182300	LEFT BRAKE (SHOWN IN PHOTO)
60202703	182350	RIGHT BRAKE

**Replacement Parts**

PART NO.	REF NO.	DESCRIPTION	ITEM
BP01-090	193800	MAGNET KIT (OLD STYLE)	N/S
BP01-110	194000	MAGNET KIT (NEW STYLE), GREEN WIRE	1
BP02-130	199250	ACTUATING ARM, LEFT HAND (NEW STYLE)	2
BP02-140	199300	ACTUATING ARM, RIGHT HAND (NEW STYLE)	2
BP04-100	205400	SHOE & LINING (ONE WHEEL)	3
BP06-120	212500	SHOE HOLD DOWN SPRINGS	4
BP07-105	216625	SHOE RETURN SPRING, DUAL RETURN, PKG OF 2	5
BP07-110	216650	SHOE RETURN SPRING, SINGLE RETURN	5A
BP08-070	220000	ADJUSTER SPRING	6
BP10-060	222400	ADJUSTER	7
BP10-220	225100	ADJUSTER DUST PLUG, PKG OF 4	8

## Dexter 12" x 2" Electric

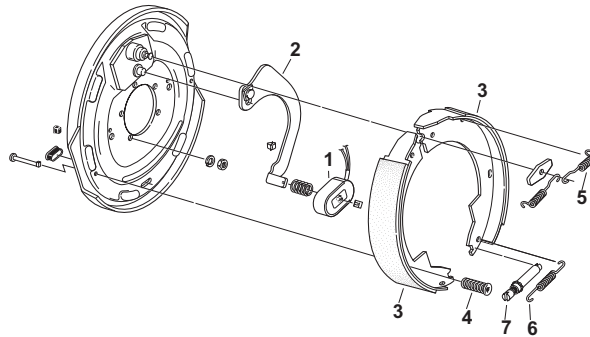

BRAKE  
ASSEMBLIES



### Dexter 12" x 2" Electric Brake Assemblies

• Capacity: 6,000 & 7,000 lbs. per pair

PART NO.	REF NO.	DESCRIPTION
23-105	182900	LEFT BRAKE (SHOWN IN PHOTO), 6,000 lb
23-106	183000	RIGHT BRAKE, 6,000 lb
23-180	184400	LEFT BRAKE, 7,000 lb
23-181	184600	RIGHT BRAKE, 7,000 lb

### Replacement Parts

PART NO.	REF NO.	DESCRIPTION	ITEM
BP01-180	195000	MAGNET KIT, 6,000 LBS (WHITE WIRE)	
BP01-185	195050	MAGNET KIT, 6,000 LBS (WHITE WIRE), GENUINE DEXTER W/PROTECTIVE WIRE SLEEVE	1
BP01-225	195850	MAGNET KIT, 7,000 LBS (BLACK WIRE), GENUINE DEXTER W/PROTECTIVE WIRE SLEEVE	1
BP02-230	201400	ACTUATING ARM, LEFT HAND	2
BP02-240	201600	ACTUATING ARM, RIGHT HAND	2
BP04-150	205950	SHOE & LINING (ONE WHEEL) 6,000 LBS	3
BP04-180	206700	SHOE & LINING (ONE WHEEL) 7,000 LBS	3
BP06-090	212400	SHOE HOLD DOWN SPRING	4
BP07-150	217400	SHOE RETURN SPRING, SINGLE RETURN	N/S
BP07-105	216625	SHOE RETURN SPRING, DUAL RETURN, PKG OF 2	5
BP08-070	220000	ADJUSTER SPRING	6
BP10-060	222400	ADJUSTER	7
BP10-220	225100	ADJUSTER DUST PLUG, PKG OF 4	8

## Dexter 12" x 2" Mobile Home Electric

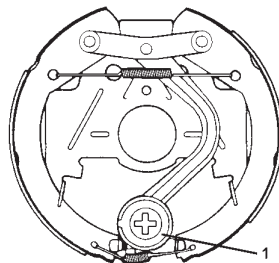

### Replacement Parts

Mobile home brakes are designed to be used solely for the purpose of transporting mobile homes. They are welded directly to the axle; therefore complete assemblies are not available and only the following replacement part is available.

PART NO.	REF NO.	DESCRIPTION	ITEM
BP01-140	194200	MAGNET KIT (BLACK WIRE)	1

## Hayes 12" x 2" Electric



BRAKE  
ASSEMBLIES

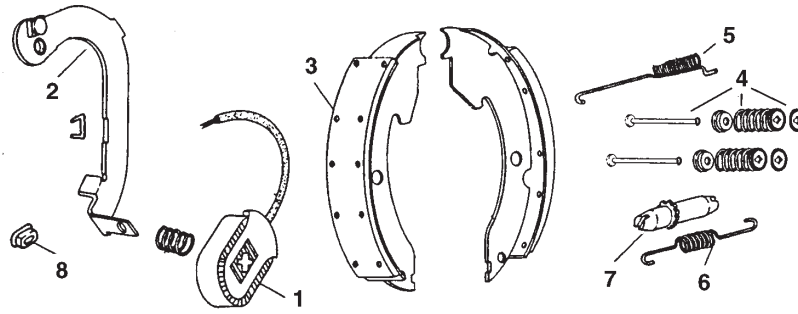

New



Old

### Hayes 12" x 2" Electric Brake Assemblies

- Capacity: 7,000 lbs. per pair
- In late 1987, brake was redesigned to use oval style magnet, replacing round magnet. Old style magnets and replacement parts are available, complete assemblies are not.

PART NO.	REF NO.	DESCRIPTION
60208712	185100	LEFT BRAKE, 7,00 lb
60208713	185150	RIGHT BRAKE, 7,00 lb

### Replacement Parts

PART NO.	REF NO.	DESCRIPTION	ITEM
BP01-160	194600	MAGNET KIT, ROUND (OLD STYLE 5.2K)	N/S
BP01-180	195000	MAGNET KIT, OVAL (NEW STYLE)	1
BP02-224	201225	ACTUATING ARM, LEFT HAND (NEW STYLE)	2
BP02-228	201250	ACTUATING ARM, RIGHT HAND (NEW STYLE)	2
BP04-185	206725	SHOE & LINING (ONE WHEEL)	3
BP06-090	212400	SHOE HOLD DOWN SPRING	4
BP07-150	217400	SHOE RETURN SPRING, SINGLE RETURN	5
BP08-070	220000	ADJUSTER SPRING	6
BP10-060	222400	ADJUSTER	7
BP10-220	225100	ADJUSTER DUST PLUG, PKG OF 4	8

## Foreman 12" x 2" Electric

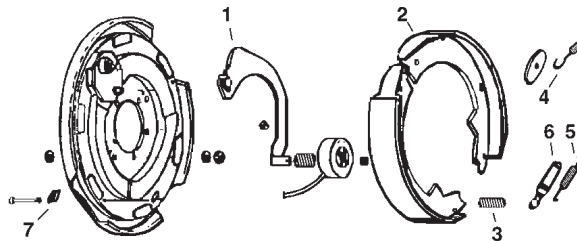

### Replacement Parts

Due to production being discontinued in 1980, only the following replacement parts are available. Please do not confuse this brake or magnet with the mobile home brake. (See C-11 for mobile home brake.) The magnet size is different and the Foreman magnet has white wire leads.

PART NO.	REF NO.	DESCRIPTION	ITEM
BP02-230	201400	ACTUATING ARM, LEFT HAND	1
BP02-240	201600	ACTUATING ARM, RIGHT HAND	1
BP04-150	205950	SHOE & LINING (ONE WHEEL)	2
BP06-090	212400	SHOE HOLD DOWN SPRINGS	3
BP07-105	216625	SHOE RETURN SPRING, PKG OF 2	4
BP08-070	220000	ADJUSTER SPRING	5
BP10-060	222400	ADJUSTER	6
BP10-220	225100	ADJUSTER DUST PLUG, PKG OF 4	7



## Fayette 12" x 2" Electric



BRAKE  
ASSEMBLIES

### Replacement Parts

• Due to production being discontinued in 1984, only the following replacement parts are available.

PART NO.	REF NO.	DESCRIPTION
BP04-150	205950	SHOE & LINING (ONE WHEEL)
BP06-090	212400	SHOE HOLD DOWN SPRINGS
BP08-070	220000	ADJUSTER SPRING
BP07-150	217400	SHOE RETURN SPRING
BP10-060	222400	ADJUSTER
BP10-220	225100	ADJUSTER DUST PLUG, PKG OF 4

## Dexter 12" x 3" Electric

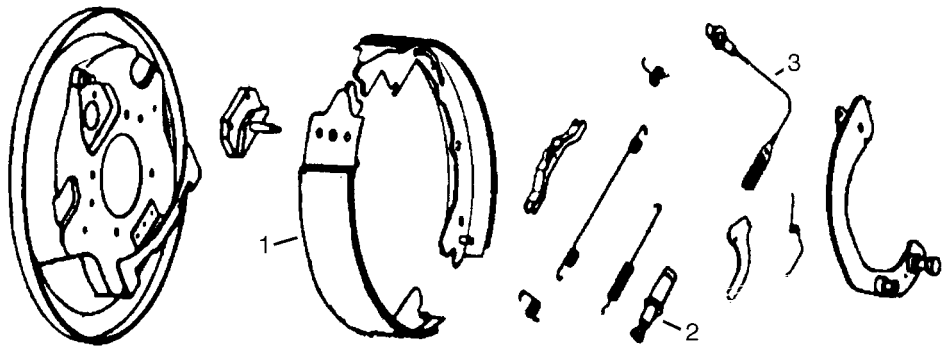

### Replacement Parts

• Capacity: 7,500 lbs. per pair

• Production of this brake assembly was discontinued in March of 1981. Parts shown are the only items available.

PART NO.	REF NO.	DESCRIPTION	ITEM
BP04-200	206800	SHOE & LINING (ONE WHEEL) LEFT HAND	1
BP04-210	207000	SHOE & LINING (ONE WHEEL) RIGHT HAND	1
BP10-135	223700	ADJUSTER, LEFT HAND	2
BP10-145	223900	ADJUSTER, RIGHT HAND	2
BP13-023	225500	ADJUSTER CABLE	3



## Hayes 12" x 3 1/4" Electric

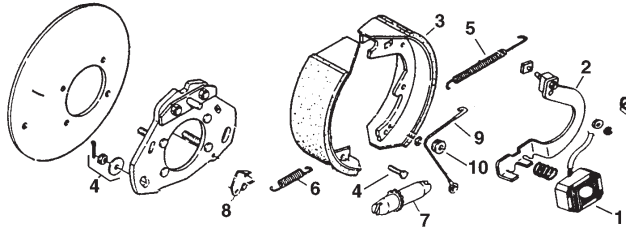

BRAKE ASSEMBLIES



### Hayes 12" x 3 1/4" Electric Brake Assemblies

- Capacity: 8,000 lbs. per pair
- In 1995 this brake was redesigned to use the ventilated magnet, replacing the round magnet.

PART NO.	REF NO.	DESCRIPTION
60204403	185600	LEFT BRAKE (SHOWN IN PHOTO)
60204303	185800	RIGHT BRAKE

### Replacement Parts

PART NO.	REF NO.	DESCRIPTION	ITEM
BP01-285	197100	MAGNET KIT, 8,000 LBS VENTILATED DESIGN, AFTER 1995	1
BP02-303	203025	ACTUATING ARM, RIGHT HAND, AFTER 1995	2
BP02-305	203050	ACTUATING ARM, LEFT HAND, AFTER 1995	2
BP04-220	207800	SHOE & LINING (ONE WHEEL)	3
BP06-195	213500	SHOE HOLD DOWN KIT (ONE WHEEL)	4
BP07-200	218400	SHOE RETURN SPRING	5
BP08-180	221600	ADJUSTER SPRING	6
BP10-110	223200	ADJUSTER, RIGHT HAND	7
BP10-120	223400	ADJUSTER, LEFT HAND	7
BP10-190	224600	ADJUSTER LEVER, RIGHT HAND	8
BP10-200	224800	ADJUSTER LEVER, LEFT HAND	8
BP13-040	225800	ADJUSTER CABLE	9
BP13-050	226000	ADJUSTER CABLE PULLEY	10



## Dexter 12 1/4" x 2 1/2" Electric

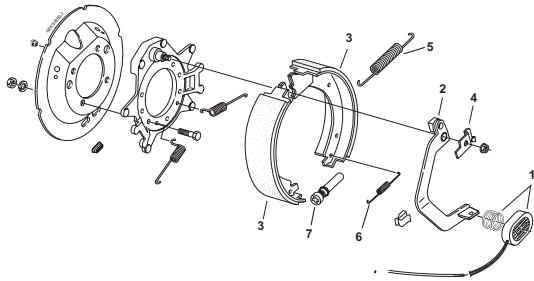

### Dexter 12 1/4" x 2 1/2" Electric Brake Assembly

- Capacity: 7,200 lbs. per pair
- In May, 2000 this brake was redesigned. New design utilizes a cast backing plate.

PART NO.	REF NO.	DESCRIPTION
23-369	185300	RIGHT BRAKE, 9 BOLT, STAMPED BACKING PLATE (SHOWN IN PHOTO)
23-370	185400	LEFT BRAKE, 9 BOLT, STAMPED BACKING PLATE
23-428	185410	RIGHT BRAKE, 4 BOLT, CAST BACKING PLATE
23-429	185420	LEFT BRAKE, 4 BOLT, CAST BACKING PLATE

### Replacement Parts

PART NO.	REF NO.	DESCRIPTION	ITEM
BP01-265	196700	MAGNET KIT, OVAL (WHITE WIRE)	1
BP02-270	202400	ACTUATING ARM, LEFT HAND	2
BP02-275	202500	ACTUATING ARM, RIGHT HAND	2
BP04-235	208100	SHOE & LINING (ONE WHEEL), STAMPED BACKING PLATE	N/S
BP04-236	208110	SHOE & LINING, CAST BACKING PLATE, LH	3
BP04-238	208120	SHOE & LINING, CAST BACKING PLATE, RH	3
BP06-240	214400	SHOE HOLD DOWN KIT (ONE WHEEL)	4
BP07-190	218000	SHOE RETURN SPRING KIT (ONE WHEEL)	5
BP08-070	220000	ADJUSTER SPRING	6
BP10-090	222900	ADJUSTER	7

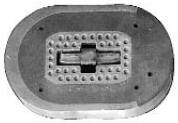

**Dexter - 4 Bolt Flange - 12 1/4" x 3 3/8" Electric**

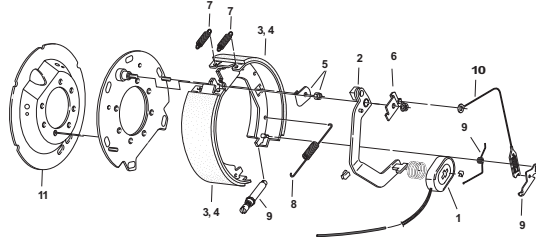

BRAKE  
ASSEMBLIES

**Replacement Parts Stamped Backing Plate**

- Capacity: 9,000 lbs. per pair
- In October 1989, the 9,000 lb. brake was changed from a 4 bolt to a 7 bolt. (See next page for 7 bolt brake.)
- September 1992, the magnet was upgraded to an oval design for increased efficiency and magnet life. The old style is no longer available.
- Redesigned with forward self-adjust feature in June of 1996.
- Redesigned with a cast backing plate in May of 2000. (Below)

PART NO.	REF NO.	DESCRIPTION	ITEM
BP01-265	196700	MAGNET KIT, 8,000 LB OVAL (WHITE WIRE)	1
BP01-301	197410	MAGNET KIT, 9-10K OVAL (YELLOW WIRE)	1
BP02-315	203300	ACTUATING ARM, LEFT HAND	2
BP02-325	203500	ACTUATING ARM, RIGHT HAND	N/S
BP02-327	203550	ACTUATING ARM, LEFT HAND FOR FORWARD ADJUST	2
BP02-328	203560	ACTUATING ARM, RIGHT HAND FOR FORWARD ADJUST	N/S
BP04-240	208200	SHOE & LINING (ONE WHEEL) LEFT HAND	3
BP04-250	208400	SHOE & LINING (ONE WHEEL) RIGHT HAND	4
BP06-240	214400	SHOE HOLD DOWN KIT (ONE WHEEL)	5
BP06-280	215200	ACTUATING ARM, LEFT HAND	6
BP06-290	215400	ACTUATING ARM, RIGHT HAND	6
BP07-225	218900	SHOE RETURN SPRING SET (ONE EACH GREEN & BLACK)	7
BP08-150	220900	ADJUSTER SPRING	8
BP10-135	223700	ADJUSTER, LEVER & SPRING, LEFT HAND	9
BP10-145	223900	ADJUSTER, LEVER & SPRING, RIGHT HAND	9
BP13-020	225400	ADJUSTER CABLE	10
BP15-015	227700	BRAKE DUST SHIELD METAL (1-PIECE) FOR DROP SPINDLE, 4 BOLT 8K	11
BP15-040	228200	BRAKE DUST SHIELD (2-PIECE) FOR STRAIGHT SPINDLE, 4 BOLT	N/S

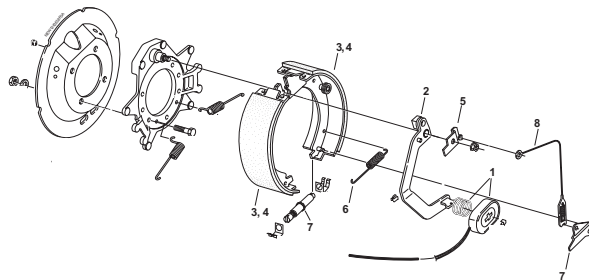

**Brake Assemblies Cast Backing Plate**

PART NO.	REF NO.	DESCRIPTION
23-434	186110	LEFT BRAKE, 4 BOLT
23-435	186210	RIGHT BRAKE, 4 BOLT (SHOWN IN PHOTO)

**Replacement Parts Cast Backing Plate**

PART NO.	REF. NO.	DESCRIPTION	ITEM
BP01-265	196700	MAGNET KIT, 8,000 LB OVAL (WHITE WIRE)	1
BP02-315	203300	ACTUATING ARM, LEFT HAND	2
BP02-325	203500	ACTUATING ARM, RIGHT HAND	N/S
BP04-245	208300	SHOE & LINING (ONE WHEEL) LEFT HAND	3
BP04-255	208500	SHOE & LINING (ONE WHEEL) RIGHT HAND	4
BP06-280	215200	ARM/SHOE RETAINER, LEFT HAND	5
BP06-290	215400	ARM/SHOW RETAINER, RIGHT HAND	N/S
BP07-190	218000	SHOE RETURN SPRING	N/S
BP08-155	220910	ADJUSTER SPRING	6
BP10-136	223710	ADJUSTER & LEVER	7
BP10-146	2239100	ADJUSTER & LEVER	N/S
BP13-022	225402	ADJUSTER CABLE	8
BP13-022	225402	ADJUSTER CABLE	8

**Dexter - 7 Bolt Flange 12 1/4" x 3 3/8" Electric**

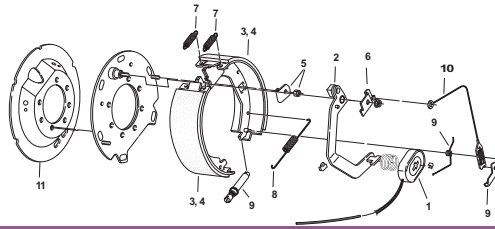

BRAKE ASSEMBLIES

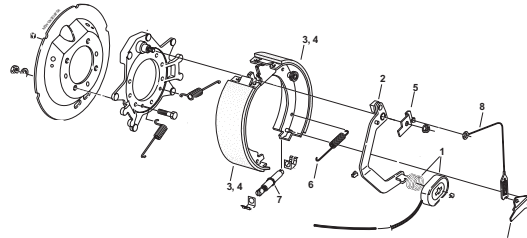

**Replacement Parts Stamped Backing Plate**

- Capacity: 10,000 lbs. per pair
- In October 1989, the 9,000 lb brake was changed from a 4 bolt to a 7 bolt.
- In September 1992, the magnet was upgraded to an oval design for increased efficiency and magnet life.
- Redesigned with forward adjust feature in June of 1996.
- Redesigned with cast backing plate in May of 2000. (See below)

PART NO.	REF NO.	DESCRIPTION	ITEM
BP01-301	197410	MAGNET KIT, 9 & 10K GD "NEW STYLE OVAL" (YELLOW WIRE)	1
BP02-315	203300	ACTUATING ARM, LEFT HAND FOR NEW STYLE OVAL MAGNET	2
BP02-325	203500	ACTUATING ARM, RIGHT HAND FOR NEW STYLE OVAL MAGNET	N/S
BP02-327	203550	ACTUATING ARM, LEFT HAND FOR FORWARD ADJUST BRAKE	N/S
BP02-328	203560	ACTUATING ARM, RIGHT HAND FOR FORWARD ADJUST BRAKE	N/S
BP04-240	208200	SHOE & LINING (ONE WHEEL) LEFT HAND	3
BP04-250	208400	SHOE & LINING (ONE WHEEL) RIGHT HAND	4
BP06-240	214400	SHOE HOLD DOWN KIT (ONE WHEEL)	5
BP06-280	215200	ACTUATING ARM RETAINER, LEFT HAND	6
BP06-290	215400	ACTUATING ARM RETAINER, RIGHT HAND	6
BP07-225	218900	SHOE RETURN SPRING SET (ONE EACH GREEN & BLACK)	7
BP08-150	220900	ADJUSTER SPRING	8
BP10-135	223700	ADJUSTER, LEVER & SPRING, LEFT HAND	9
BP10-145	223900	ADJUSTER, LEVER & SPRING, RIGHT HAND	9
BP13-020	225400	ADJUSTER CABLE	10
BP15-085	229100	BRAKE DUST SHIELD METAL (1-PIECE) 7 BOLT	11

**Brake Assemblies Cast Backing Plate**

PART NO.	REF NO.	DESCRIPTION
23-450	186235	LEFT BRAKE, 9K AND 10K GENERAL DUTY, 7 BOLT (SHOWN IN PHOTO)
23-451	186255	RIGHT BRAKE, 9K AND 10K GENERAL DUTY, 7 BOLT

**Replacement Parts**

PART NO.	REF. NO.	DESCRIPTION	ITEM
BP01-301	197410	MAGNET KIT, 9K & 10K GD, "NEW STYLE OVAL" (YELLOW WIRE)	1
BP02-315	203300	ACTUATING ARM, LEFT HAND FOR NEW STYLE OVAL MAGNET	2
BP02-325	203500	ACTUATING ARM, RIGHT HAND FOR NEW STYLE OVAL MAGNET	N/S
BP04-245	208300	SHOE & LINING (ONE WHEEL) LEFT HAND	3
BP04-255	208500	SHOE & LINING (ONE WHEEL) RIGHT HAND	4
BP06-280	215200	ARM/SHOE RETAINER, LEFT HAND	5
BP06-290	215400	ARM/SHOE, RETAINER, RIGHT HAND	N/S
BP07-190	218000	SHOE RETURN SPRING SET	N/S
BP08-155	220910	ADJUSTER SPRING	6
BP10-136	223710	ADJUSTER & LEVER, LEFT HAND	9
BP10-146	223910	ADJUSTER & LEVER, RIGHT HAND	9
BP13-022	225402	ADJUSTER CABLE	8

### Warner 12 1/4" x 3 1/2" Electric

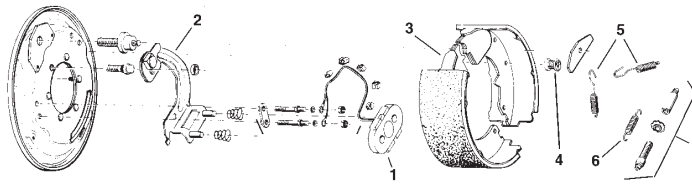

BRAKE  
ASSEMBLIES

#### Warner 12 1/4" x 3 1/2" Electric Brake Assemblies

- Capacity: 10,000 lbs. per pair

PART NO.	REF. NO.	DESCRIPTION
1301-13	186400	LEFT BRAKE (SHOWN IN PHOTO)
1301-12	186600	RIGHT BRAKE

#### Replacement Parts

PART NO.	REF. NO.	DESCRIPTION	ITEM
BP01-270	196800	MAGNET KIT	1
BP02-330	203600	ACTUATING ARM, RIGHT HAND	2
BP02-340	203800	ACTUATING ARM, LEFT HAND	N/S
BP04-280	209000	SHOE AND LINING (ONE WHEEL)	3
BP06-300	215600	SHOE HOLD DOWN SPRING	4
BP07-175	217700	SHOE RETURN SPRINGS	5
BP08-120	220400	ADJUSTER SPRING	6
BP10-080	222800	ADJUSTER	7

### Hayes 12 1/4" x 3 1/2" Electric

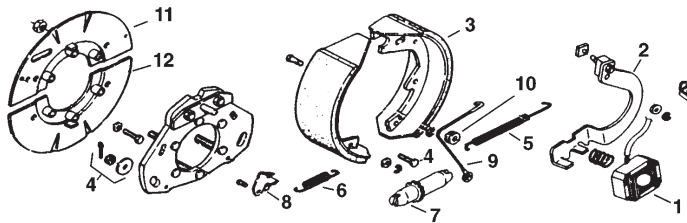

#### Hayes 12 1/4" x 3 1/2" Electric Brake Assemblies

- Capacity: 12,000 lbs. per pair
- Fits: 9K through 12K Axles
- In 1987 the 10K brake was redesigned to use the "Ventilated Magnet"
- In 1989 the 12K brake was redesigned to use the "Ventilated Magnet"
- In 1995 the 9K brake was redesigned to use the "Ventilated Magnet"

PART NO.	REF. NO.	DESCRIPTION
10257	186700	LEFT BRAKE (SHOWN IN PHOTO)
10259	186900	RIGHT BRAKE

#### Replacement Parts

PART NO.	REF. NO.	DESCRIPTION	ITEM
BP01-270	196800	MAGNET KIT, 12,000 LBS, BEFORE 1989	N/S
BP01-285	197100	VENT MAGNET, FITS 9K AFTER 94, 10K AFTER 87, 12K AFTER 89	1
BP02-303	203025	ACTUATING ARM, RIGHT HAND FOR VENT MAGNET	2
BP02-305	203050	ACTUATING ARM, LEFT HAND, FOR VENT MAGNET	N/S
BP04-290	209200	SHOE & LINING (ONE WHEEL)	3
BP06-195	213500	SHOE HOLD DOWN KIT (ONE WHEEL)	4
BP07-200	218400	SHOE RETURN SPRING	5
BP08-180	221600	ADJUSTER SPRING	6
BP10-110	223200	ADJUSTER, RIGHT HAND	7
BP10-120	223400	ADJUSTER, LEFT HAND	N/S
BP10-190	224600	ADJUSTER LEVER, RIGHT HAND	8
BP10-200	224800	ADJUSTER LEVER, LEFT HAND	N/S
BP13-040	225800	ADJUSTER CABLE	9
BP13-050	226000	ADJUSTER CABLE PULLEY	10
BP15-120	229800	BRAKE DUST SHIELD (TOP), RIGHT HAND	11
BP15-130	230000	BRAKE DUST SHIELD (TOP), LEFT HAND	N/S
BP15-100	229400	BRAKE DUST SHIELD (LOWER)	12



Old Style



New Style

## Dexter 12 1/4" x 4" Electric

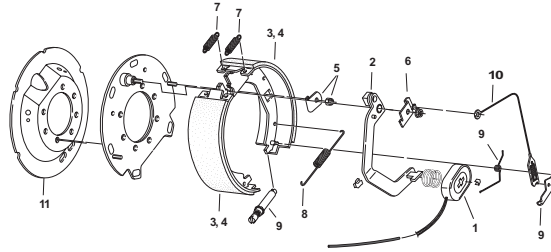

BRAKE ASSEMBLIES



New



Old

### Replacement Parts Stamped Backing Plate (Parts only)

- Capacity: 10,000 lbs. per pair
- In September 1992 the magnet was upgraded to an oval design for increased efficiency & magnet life.
- Brake was redesigned with forward self-adjust feature in June of 1996.
- Brake was redesigned with cast backing plate in May of 2000. (See below.)

PART NO.	REF NO.	DESCRIPTION	ITEM
BP01-301	197410	MAGNET KIT, 10K NEW STYLE OVAL (YELLOW WIRE)	N/S
BP02-315	203300	ACTUATING ARM, LEFT HAND FOR NEW STYLE OVAL MAGNET	
BP02-325	203500	ACTUATING ARM, RIGHT HAND FOR NEW STYLE OVAL MAGNET	
BP02-327	203550	ACTUATING ARM, LEFT HAND FOR FORWARD ADJUST BRAKES	2
BP02-328	203560	ACTUATING ARM, RIGHT HAND FOR FORWARD ADJUST BRAKES	2
BP04-320	209600	SHOE & LINING (ONE WHEEL) LEFT HAND	3
BP04-330	209800	SHOE & LINING (ONE WHEEL) RIGHT HAND	4
BP06-240	214400	SHOEHOLD DOWN KIT (ONE WHEEL)	5
BP06-280	215200	ACTUATING ARM RETAINER, LEFT HAND	6
BP06-290	215400	ACTUATING ARM RETAINER, RIGHT HAND	6
BP07-225	218900	SHOE RETURN SPRING SET (1 EACH GREEN & BLACK)	7
BP08-150	220900	ADJUSTER SPRING	8
BP10-135	223700	ADJUSTER, LEVER & SPRING, LEFT HAND	9
BP10-145	223900	ADJUSTER, LEVER & SPRING, RIGHT HAND	9
BP13-020	225400	ADJUSTER CABLE	10
BP15-150	230300	BRAKE DUST SHIELD METAL (1 PIECE) 7 BOLT	11

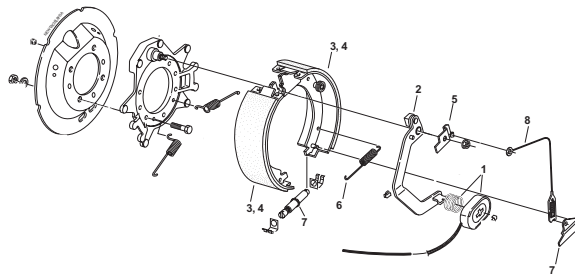

### Electric Brake Assemblies Cast Backing Plate

PART NO.	REF NO.	DESCRIPTION
23-438	188060	LEFT BRAKE, 7 BOLT (SHOWN IN PHOTO)
23-439	188080	RIGHT BRAKE, 7 BOLT

### Replacement Parts

PART NO.	REF. NO.	DESCRIPTION	ITEM
BP01-301	197410	MAGNET KIT, 10K NEW STYLE OVAL (YELLOW WIRE)	1
BP02-315	203300	ACTUATING ARM, LEFT HAND FOR NEW STYLE OVAL MAGNET	2
BP02-325	203500	ACTUATING ARM, RIGHT HAND FOR NEW STYLE OVAL MAGNET	N/S
BP04-325	209610	SHOE & LINING (ONE WHEEL) LEFT HAND	3
BP04-335	209810	SHOE & LINING (ONE WHEEL) RIGHT HAND	4
BP07-190	218000	SHOE RETURN SPRING SET (1 EACH GREEN & BLACK)	7
BP08-155	220910	ADJUSTER SPRING	8
BP10-136	223710	ADJUSTER, LEVER & SPRING, LEFT HAND	9
BP10-146	223910	ADJUSTER, LEVER & SPRING, RIGHT HAND	9
BP06-280	215200	ARM/SHOE RETAINER, LEFT HAND	5
BP06-290	215400	ARM/SHOE RETAINER, RIGHT HAND	N/S
BP13-022	225402	ADJUSTER CABLE	8

## Dexter 12 1/4" x 5" Electric

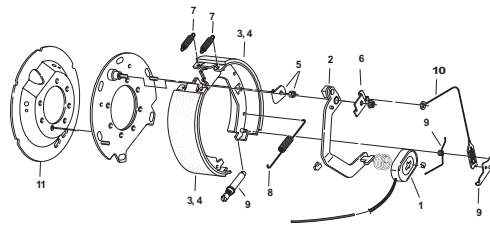

### Replacement Parts

- Capacity: 12,000 lbs. & 15,000 lbs. per pair
- In September 1992, the magnet was upgraded to an oval design for increased efficiency and magnet life. The old style is no longer available.
- Redesigned with forward self-adjust feature in June of 1996.
- Redesigned with a cast backing plate in May of 2000. (See below)

PART NO.	REF. NO.	DESCRIPTION	ITEM
BP01-311	197625	MAGNET KIT, 15K NEW STYLE OVAL (BLUE WIRE)	1
BP02-375	204215	ACTUATING ARM, LEFT HAND FOR NEW STYLE OVAL MAGNET	N/S
BP02-380	204220	ACTUATING ARM, RIGHT HAND FOR NEW STYLE OVAL MAGNET	N/S
BP02-385	203550	ACTUATING ARM, LEFT HAND FOR FOWARD ADJUST BRAKES	2
BP02-390	203560	ACTUATING ARM, RIGHT HAND FOR FORWARD ADJUST BRAKES	2
BP04-360	210400	SHOE & LINING (ONE WHEEL) LEFT HAND	3
BP04-370	210600	SHOE & LINING (ONE WHEEL) RIGHT HAND	4
BP06-240	214400	SHOE HOLD DOWN KIT (ONE WHEEL)	5
BP06-280	215200	SHOE HOLD DOWN RETAINER, LEFT HAND	6
BP06-290	215400	SHOE HOLD DOWN RETAINER, RIGHT HAND	6
BP07-225	218900	SHOE RETURN SPRING (1 EACH GREEN & BLACK)	7
BP08-150	220900	ADJUSTER SPRING	8
BP10-135	223700	ADJUSTER, LEVER & SPRING, LEFT HAND	9
BP10-145	223900	ADJUSTER, LEVER & SPRING, RIGHT HAND	9
BP13-020	225400	ADJUSTER CABLE	10
BP15-190	231100	BRAKE DUST SHIELD, METAL, (1 PIECE) 7 BOLT	11



New



Old

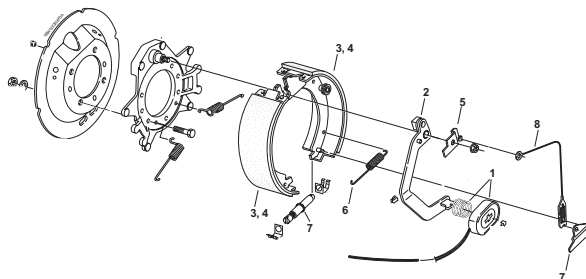

### Electric Brake Assemblies Cast Backing Plate

PART NO.	REF. NO.	DESCRIPTION
23-442	188445	LEFT BRAKE, 7 BOLT, 12,000 LB CAPACITY (BLACK WIRE) SHOWN IN PHOTO
23-443	188455	RIGHT BRAKE, 7 BOLT, 12,000 LB CAPACITY (BLACK WIRE))
23-446	188830	LEFT BRAKE, 7 BOLT, 15,000 LB CAPACITY (BLUE WIRE)
23-447	188840	RIGHT BRAKE, 7 BOLT, 15,000 LB CAPACITY (BLUE WIRE))

### Replacement Parts

PART NO.	REF. NO.	DESCRIPTION	ITEM
BP01-306	197430	MAGNET KIT, 12K NEW STYLE OVAL (BLACK WIRE)	1
BP01-311	197625	MAGNET KIT, 15K NEW STYLE OVAL (BLUE WIRE)	1
BP02-385	204250	ACTUATING ARM, LEFT HAND	2
BP02-390	204260	ACTUATING ARM, RIGHT HAND	N/S
BP04-365	210410	SHOE & LINING (ONE WHEEL) LEFT HAND	3
BP04-375	210610	SHOE & LINING (ONE WHEEL) RIGHT HAND	4
BP06-280	215200	ARM/SHOE RETAINER, LEFT HAND	5
BP06-290	215400	ARM/SHOE RETAINER, RIGHT HAND	N/S
BP07-190	218000	SHOE RETURN SPRING (1 EACH GREEN & BLACK)	N/S
BP08-155	220910	ADJUSTER SPRING	6
BP10-136	223710	ADJUSTER, LEVER & SPRING, LEFT HAND	9
BP10-146	223910	ADJUSTER, LEVER & SPRING, RIGHT HAND	9
BP13-022	225402	ADJUSTER CABLE	8

BRAKE ASSEMBLIES

## How To Select Hydraulic Brakes & Brake Parts

### THE SINGLE-SERVO / DUO-SERVO DIFFERENCE:

1. **SINGLE-SERVO:** Single plunger coming from the wheel cylinder, most commonly used with Surge Brake applications.
2. **DUO-SERVO:** Two plungers coming from the wheel cylinder, stops vehicle in both forward and reverse motion.

### SELECTING HYDRAULIC BRAKE PARTS:

1. Determine the size of your brake.
  - a. Measure the diameter of the mounted brake shoe.
  - b. Measure the width of the lining.
2. Determine the manufacturer of your brake.
  - a. Is the manufacturer's name on the backing plate?
  - b. Compare to complete Brake Assembly or to exploded drawings in this catalog.
3. Select each part you need. The exploded drawings of each brake are to assist you in selecting the parts you need. Though all parts may be shown, we carry replacement parts only for those that are numbered. Parts labeled "Parts Only" indicate that complete brake assemblies are not available.



Single-Servo Cylinder

### USING THE HYDRAULIC BRAKE CHART:

1. Find the picture that matches the assembly or the part you need.
2. The part and reference numbers are just below the picture of your assembly or part. Part numbers are placed beside the photo of individual replacement parts. Use the part number to order what you need.
3. Double check your part against its listing in the pages which show the exploded drawings.
4. Call or fax your order to the location nearest you.



Duo-Servo Cylinder

### REASONS WHY BRAKE HARDWARE SHOULD BE REPLACED:

- A. Worn, weak return springs will cause the brake linings to drag against the drum and cause premature brake failure.
- B. Hold down springs will lose their tension and allow the brake shoes to wobble or ride up against the face of the brake drum, causing premature lining failure.
- C. A frozen adjusting screw will not allow shoes to be adjusted properly.
- D. Rubber dust plugs will crack with age and allow dirt to contaminate linings. (not shown or illustrated)
- E. A stretched self-adjusting cable or worn lever prevents the self-adjusting lever from properly aligning the shoes. (not shown or illustrated)

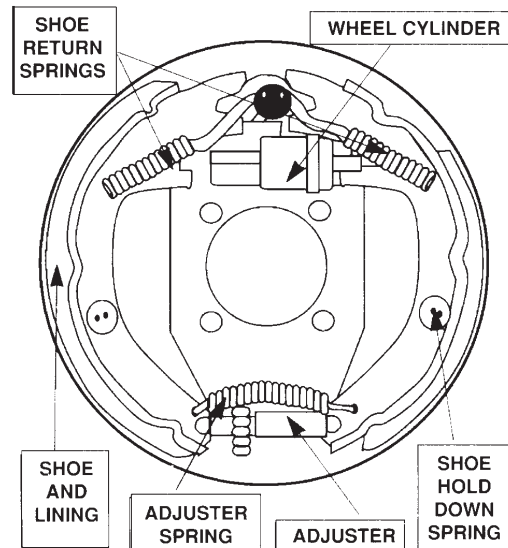



**Complete Brake Assemblies**

Manufacturer	7" x 1 3/4" ATWOOD	7" x 1 3/4" DEXTER	10" x 2 1/4" DEXTER	10" x 2 1/4" DEXTER FREE-BACKING	10" x 2 1/4" ATWOOD	10" x 2 1/4" BENDIX
Capacity Per Pair	2,500 lbs	2,500 lbs	3,500 lbs	3,500 lbs	3,500 lbs	3,500 lbs
Left Hand Part No.	Parts Only	23-398	23-312	23-344	Parts Only	Parts Only
Left Hand Ref. No.	N/A	174010	174625	175200	N/A	N/A
Right Hand Part No.	Parts Only	23-399	23-313	23-345	Parts Only	Parts Only
Right Hand Ref. No.	N/A	174210	174650	175250	N/A	N/A
Brake Featured On:	PAGE C-25	PAGE C-25	PAGE C-26	PAGE C-26	PAGE C-26	PAGE C-26

BRAKE  
ASSEMBLIES



**Hydraulic Brake Parts Replacement Chart**

Shoe Lining L.H.		Part No. BP04-060 Ref. No. 204800	Part No. BP04-050 Ref. No. 204700	Part No. BP04-120 Ref. No. 205800	Part No. BP04-123 Ref. No. 205810	Part No. BP04-120 Ref. No. 205800	Part No. BP04-120 Ref. No. 205800
Shoe Lining R.H.		Same As Left Hand	Same As Left Hand	Same As Left Hand	Same As Left Hand	Same As Left Hand	Same As Left Hand
Shoe Hold Down Spring		Part No. BP06-050 Ref. No. 211800	Part No. BP06-045 Ref. No. 211500	Part No. BP06-120 Ref. No. 212500	Part No. BP06-120 Ref. No. 212500	Part No. BP06-120 Ref. No. 212500	Part No. BP06-120 Ref. No. 212500
Shoe Return Spring L.H.		Part No. BP07-075 Ref. No. 216225	Part No. BP07-050 Ref. No. 215900	Part No. BP07-105 Ref. No. 216625	Part No. BP07-120 Ref. No. 216825	Part No. BP07-105 Ref. No. 216625	Part No. BP07-105 Ref. No. 216625
Shoe Return Spring R.H.		Part No. BP07-065 Ref. No. 216025	Same As Left Hand	Same As Left Hand	Same As Left Hand	Same As Left Hand	Same As Left Hand
Adjuster Spring		Part No. BP08-050 Ref. No. 219800	Part No. BP08-045 Ref. No. 219700	Part No. BP08-080 Ref. No. 220200	Part No. BP08-080 Ref. No. 220200	Part No. BP08-110 Ref. No. 220350	Part No. BP08-080 Ref. No. 220200
Adjuster L.H.		Part No. BP10-050 Ref. No. 222200	Part No. BP10-045 Ref. No. 222100	Part No. BP10-060 Ref. No. 222400	Part No. BP10-060 Ref. No. 222400	Part No. BP10-050 Ref. No. 222200	Part No. BP10-080 Ref. No. 222800
Adjuster R.H.		Same As Left Hand	Same As Left Hand	Same As Left Hand	Same As Left Hand	Same As Left Hand	Same As Left Hand
Adjuster Plug		Part No. BP10-220 Ref. No. 225100	Part No. BP10-220 Ref. No. 225100	Part No. BP10-220 Ref. No. 225100	Part No. BP10-220 Ref. No. 225100	Part No. BP10-220 Ref. No. 225100	Part No. BP10-220 Ref. No. 225100
Wheel Cylinder Rebuild Kits		N/A	N/A	N/A	N/A	N/A	N/A
Wheel Cylinder Assemblies L.H.		N/A	Part No. BP17-010 Ref. No. 233100	Part No. BP17-030 Ref. No. 233400	Part No. BP17-030 Ref. No. 233400	Part No. BP17-030 Ref. No. 233400	Part No. BP17-030 Ref. No. 233400
Wheel Cylinder Assemblies R.H.		N/A.	Part No. BP17-015 Ref. No. 233150	Part No. BP17-020 Ref. No. 233200	Part No. BP17-020 Ref. No. 233200	Part No. BP17-020 Ref. No. 233200	Part No. BP17-020 Ref. No. 233200









### Complete Brake Assemblies







MANUFACTURER	10" x 2 1/4" DEMCO/DICO	10" x 2 1/4" DEMCO/DICO FREE-BACKING	12" x 2" DEX SINGLE-SERVO	12" X 2" DEX FREE-BACKING	12" X 2" DEX DUO-SERVO
CAPACITY PER PAIR	3,500 LBS	3,500 LBS	5,200 LBS	6,000 LBS	5,200 LBS
LEFT HAND PART NO.	18788	40716	23-324	23-342	23-322
LEFT HAND REF. NO.	174500	175150	175425	175500	176225
RIGHT HAND PART NO.	18787	40715	23-325	23-343	23-323
RIGHT HAND REF. NO.	174400	175100	175450	175550	176250
BRAKE FEATURED ON	PAGE C-26	PAGE C-26	PAGE C-27	PAGE C-27	PAGE C-28



### Hydraulic Brake Parts Replacement Chart







Shoe Lining L.H.		PART NO. BP04-120 REF. NO. 205800	PART NO. BP04-126 REF. NO. 205815	PART NO. BP04-160 REF. NO. 206000	PART NO. BP04-164 REF. NO. 206200	PART NO. BP04-160 REF. NO. 206000
Show Lining R.H.		SAME AS LEFT HAND	SAME AS LEFT HAND	SAME AS LEFT HAND	PART NO. BP04-162 REF. NO. 206100	SAME AS LEFT HAND
Show Hold Down Spring		PART NO. BP06-120 REF. NO. 212500	PART NO. BP06-120 REF. NO. 212500	PART NO. BP06-090 REF. NO. 212400	PART NO. BP06-090 REF. NO. 212400	PART NO. BP06-090 REF. NO. 212400
Shoe Return Spring L.H.		PART NO. BP07-105 REF. NO. 216625	PART NO. BP07-122 REF. NO. 216845	PART NO. BP07-175 REF. NO. 217700	PART NO. BP07-121 REF. NO. 216830	PART NO. BP07-175 REF. NO. 217700
Shoe Return Spring R.H.		SAME AS LEFT HAND	SAME AS LEFT HAND	SAME AS LEFT HAND	SAME AS LEFT HAND	SAME AS LEFT HAND
Adjuster Spring		PART NO. BP08-080 REF. NO. 220200	PART NO. BP08-080 REF. NO. 220200	PART NO. BP08-120 REF. NO. 220400	PART NO. BP08-120 REF. NO. 220400	PART NO. BP08-120 REF. NO. 220400
Adjuster L.H.		PART NO. BP10-060 REF. NO. 222400	PART NO. BP10-060 REF. NO. 222400	PART NO. BP10-045 REF. NO. 222100	PART NO. BP10-080 REF. NO. 222800	PART NO. BP10-045 REF. NO. 222100
Adjuster R.H.		SAME AS LEFT HAND	SAME AS LEFT HAND	SAME AS LEFT HAND	SAME AS LEFT HAND	SAME AS LEFT HAND
Adjuster Plug		PART NO. BP10-220 REF. NO. 225100	PART NO. BP10-220 REF. NO. 225100	PART NO. BP10-220 REF. NO. 225100	PART NO. BP10-220 REF. NO. 225100	PART NO. BP10-220 REF. NO. 225100
Wheel Cylinder Rebuild Kits		N/A	N/A	N/A	N/A	N/A
Wheel Cylinder Assemblies L.H.		PART NO. BP17-030 REF. NO. 233400	PART NO. BP17-030 REF. NO. 233400	PART NO. BP17-030 REF. NO. 233400	PART NO. BP17-030 REF. NO. 233400	PART NO. BP17-050 REF. NO. 233800
Wheel Cylinder Assemblies R.H.		PART NO. BP17-020 REF. NO. 233200	PART NO. BP17-020 REF. NO. 233200	PART NO. BP17-020 REF. NO. 233200	PART NO. BP17-020 REF. NO. 233200	PART NO. BP17-040 REF. NO. 233600

## Complete Brake Assemblies

					
MANUFACTURER	12" x 2" DEMCO/DICO SINGLE-SERVO	12" x 2" DEMCO/DICO FREE-BACKING	12" x 3" BENDIX	12" x 3 1/4" HAYES	12 1/4" X 3 3/8" DEX 8K, 9K OLD
CAPACITY PER PAIR	6,000 LBS	6,000 LBS	7,500 LBS	8,000 LBS	9,000 LBS
LEFT HAND PART NO.	23511	42029	3203933	60206803	23-402
LEFT HAND REF. NO.	175400	175480	176800	177200	178205
RIGHT HAND PART NO.	23510	42028	3203934	SAME AS LEFT	23-403
RIGHT HAND REF. NO.	175350	175470	177000	HAND	178210
BRAKE FEATURED ON	PAGE C-27	PAGE C-27	PAGE C-28	PAGE C-29	PAGE C-29



## Hydraulic Brake Parts Replacement Chart

Shoe Lining L.H. 	PART NO. BP04-160 REF. NO. 206000	PART NO. BP04-168 REF. NO. 206300	PART NO. BP04-200 REF. NO. 206800	PART NO. BP04-230 REF. NO. 208000	PART NO. BP04-260 REF. NO. 208600
Shoe Lining R.H. 	SAME AS LEFT HAND	SAME AS LEFT HAND	PART NO. BP04-210 REF. NO. 207000	SAME AS LEFT HAND	PART NO. BP04-270 REF. NO. 208800
Shoe Hold Down Spring 	PART NO. BP06-090 REF. NO. 212400	PART NO. BP06-090 REF. NO. 212400	N/A	N/A	PART NO. BP06-235 REF. NO. 214300
Shoe Return Spring L.H. 	PART NO. BP07-175 REF. NO. 217700	PART NO. BP07-123 REF. NO. 216850	N/A	PART NO. BP07-215 REF. NO. 218700	PART NO. BP07-240 REF. NO. 219200
Shoe Return Spring R.H.	SAME AS LEFT HAND	SAME AS LEFT HAND	N/A	SAME AS LEFT HAND	SAME AS LEFT HAND
Adjuster Spring 	PART NO. BP08-120 REF. NO. 220400	PART NO. BP08-120 REF. NO. 220400	N/A	N/A	PART NO. BP08-150 REF. NO. 220900
Adjuster L.H. 	PART NO. BP10-080 REF. NO. 222800	PART NO. BP10-080 REF. NO. 222800	PART NO. BP10-135 REF. NO. 223700	N/A	PART NO. BP10-135 REF. NO. 223700
Adjuster R.H. 	SAME AS LEFT HAND	SAME AS LEFT HAND	PART NO. BP10-145 REF. NO. 223900	N/A	PART NO. BP10-145 REF. NO. 223900
Adjuster Plug 	PART NO. BP10-220 REF. NO. 225100	PART NO. BP10-220 REF. NO. 225100	NONE REQUIRED	NONE REQUIRED	NONE REQUIRED
Wheel Cylinder Rebuild Kits 	N/A	N/A	N/A	N/A	PART NO. BP16-040 REF. NO. 232400
Wheel Cylinder Assemblies L.H. 	PART NO. BP17-030 REF. NO. 233400	PART NO. BP17-030 REF. NO. 233400	N/A	PART NO. BP17-080 REF. NO. 234400	N/A
Wheel Cylinder Assemblies R.H. 	PART NO. BP17-020 REF. NO. 233200	PART NO. BP17-020 REF. NO. 233200	N/A	SAME AS LEFT HAND	N/A

### Complete Brake Assemblies

MANUFACTURER	12 1/4" x 3 3/8" DEX 9K,10K GD	12 1/4" x 3 1/2" HAYES	12 1/4" x 4" DEXTER	12 1/4" x 5" DEXTER 12K	12 1/4" x 5" DEXTER 15K
CAPACITY PER PAIR	10,000 LBS	12,000 LBS	10,000 LBS	12,000 LBS	15,000 LBS
LEFT HAND PART NO.	23-410	60206801	23-404	23-408	23-406
LEFT HAND REF. NO.	178275	177800	179100	179825	180250
RIGHT HAND PART NO.	23-411	SAME AS LEFT	23-405	23-409	23-407
RIGHT HAND REF. NO.	178300	HAND	179150	179850	180300
BRAKE FEATURED ON	PAGE C-30	PAGE C-30	PAGE C-31	PAGE C-32	PAGE C-32

### Hydraulic Brake Parts Replacement Chart

Shoe Lining L.H.	PART NO. BP04-260 REF. NO. 208600	PART NO. BP04-300 REF. NO. 209400	PART NO. BP04-340 REF. NO. 210000	PART NO. BP04-380 REF. NO. 210800	PART NO. BP04-380 REF. NO. 210800
Shoe Lining R.H.	PART NO. BP04-270 REF. NO. 208800	SAME AS LEFT HAND	PART NO. BP04-350 REF. NO. 210200	PART NO. BP04-390 REF. NO. 211000	PART NO. BP04-390 REF. NO. 211000
Shoe Hold Down Springs	PART NO. BP06-235 REF. NO. 214300	N/A	PART NO. BP06-235 REF. NO. 214300	PART NO. BP06-235 REF. NO. 214300	PART NO. BP06-235 REF. NO. 214300
Shoe Return Spring L.H.	PART NO. BP07-240 REF. NO. 219200	PART NO. BP07-215 REF. NO. 218700	PART NO. BP07-240 REF. NO. 219200	PART NO. BP07-240 REF. NO. 219200	PART NO. BP07-240 REF. NO. 219200
Shoe Return Spring R.H.	SAME AS LEFT HAND	SAME AS LEFT HAND	SAME AS LEFT HAND	SAME AS LEFT HAND	SAME AS LEFT HAND
Adjuster Spring	PART NO. BP08-150 REF. NO. 220900	N/A	PART NO. BP08-150 REF. NO. 220900	PART NO. BP08-150 REF. NO. 220900	PART NO. BP08-150 REF. NO. 220900
Adjuster L.H.	PART NO. BP10-135 REF. NO. 223700	N/A	PART NO. BP10-135 REF. NO. 223700	PART NO. BP10-135 REF. NO. 223700	PART NO. BP10-135 REF. NO. 223700
Adjuster R.H.	PART NO. BP10-145 REF. NO. 223900	N/A	PART NO. BP10-145 REF. NO. 223900	PART NO. BP10-145 REF. NO. 223900	PART NO. BP10-145 REF. NO. 223900
Adjuster Plug	NONE REQUIRED	NONE REQUIRED	NONE REQUIRED	N/A	N/A
Wheel Cylinder Rebuild Kits	PART NO. BP16-050 REF. NO. 232600	N/A	PART NO. BP16-050 REF. NO. 232600	PART NO. BP16-050 REF. NO. 232600	PART NO. BP16-060 REF. NO. 232625
Wheel Cylinder Assemblies L.H.	N/A	PART NO. BP17-090 REF. NO. 234600	N/A	N/A	N/A
Wheel Cylinder Assemblies R.H.	N/A	SAME AS LEFT HAND	N/A	N/A	N/A

## Dexter 7" x 1 3/4" Hydraulic Brake Assembly

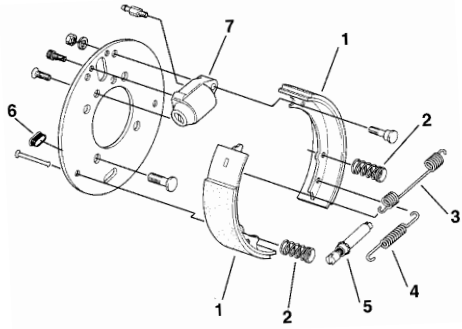

BRAKE  
ASSEMBLIES

### Dexter 7"x 1 3/4" Hydraulic Brake Assemblies

- Single-Servo
- Capacity: 2,500 lbs. per pair

Part No.	Ref. No.	Description
23-398	174010	LEFT BRAKE, 2,500 LB
23-399	174210	RIGHT BRAKE, 2,500 LB

### Replacement Parts

Part No.	Ref. No.	Description	Item
BP04-050	204700	SHOE & LINING (1 WHEEL)	1
BP06-045	211500	SHOE HOLD DOWN (1 WHEEL)	2
BP07-050	215900	SHOE RETURN SPRING	3
BP08-045	219700	ADJUSTER SPRING	4
BP10-045	222100	ADJUSTER	5
BP10-220	225100	ADJUSTER DUST PLUG	6
BP17-010	233100	WHEEL CYLINDER LEFT HAND	7
BP17-015	233150	WHEEL CYLINDER RIGHT HAND	7



## Atwood 7" x 1 3/4" Hydraulic

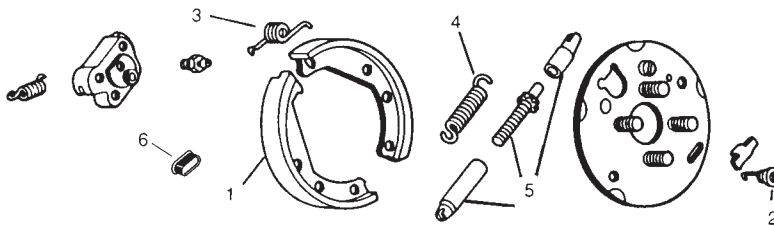

### Atwood 7"x 1 3/4" Hydraulic Brake Replacement Parts

- Single Servo
- Capacity: 2,500 lbs. per pair
- After 1985, this brake was redesigned to use a different wheel cylinder. The old style had a D-shape opening for the wheel cylinder; the new style has a round opening.

Part No.	Ref. No.	Description	Item
BP04-060	204800	SHOE AND LINING (ONE WHEEL)	1
BP06-050	211800	SHOE HOLD DOWN SPRING	2
BP07-065	216025	SHOE RETURN SPRINGS, RIGHT HAND (ONE WHEEL)	3
BP07-075	216225	SHOE RETURN SPRINGS, LEFT HAND (ONE WHEEL)	3
BP08-050	219800	ADJUSTER SPRING	4
BP10-050	222200	ADJUSTER	5
BP10-220	225100	ADJUSTER PLUG, PKG OF 4	6



**10" x 2 1/4" Hydraulic**



Standard Single-Servo



Dexter Free-backing



Demco/Dico Free-backing

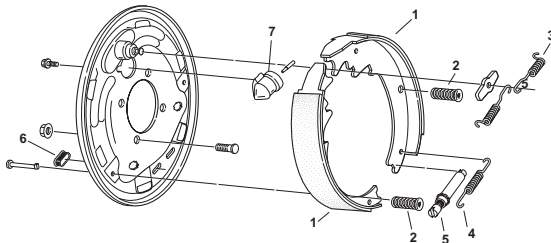

Single-Servo

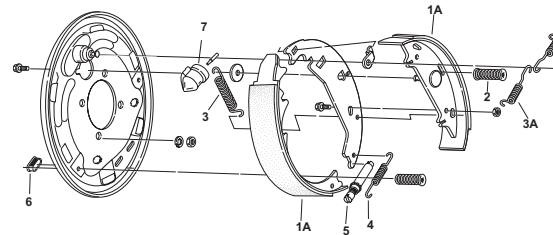

Free-Backing

**10" x 2 1/4" Hydraulic Brake Assemblies**

- Single-Servo • Capacity: 3,500 lbs. per pair
- Choose from Standard Single-Servo or Free-backing versions

Part No.	Ref. No.	Description
18787	174400	RIGHT BRAKE - DEMCO/DICO
18788	174500	LEFT BRAKE - DEMCO/DICO
23-312	174625	LEFT BRAKE - DEXTER (SHOWN IN PHOTO)
23-313	174650	RIGHT BRAKE - DEXTER
40715	175100	RIGHT BRAKE, FREE-BACKING - DEMCO/DICO (SHOWN IN PHOTO)
40716	175150	LEFT BRAKE, FREE-BACKING - DEMCO/DICO
23-344	175200	LEFT BRAKE, FREE-BACKING - DEXTER (SHOWN IN PHOTO)
23-345	175250	RIGHT BRAKE, FREE-BACKING - DEXTER

**Replacement Parts**

Part No.	Ref. No.	Description	Item
BP04-120	205800	SHOE AND LINING (ONE WHEEL)	1
BP04-123	205810	SHOE AND LINING (1 WHEEL) DEXTER FREE-BACKING	1A
BP04-126	205815	SHOE AND LINING (1 WHEEL) DEMCO/DICO FREE-BACKING	1A
BP06-120	212500	SHOE HOLD DOWN SPRINGS	2
BP07-105	216625	SHOE RETURN SPRINGS	3
BP07-120	216825	SHOE RETURN SPRING SET, DEXTER FREE-BACKING (QTY 3)	3A
BP07-122	216845	SHOE RETURN SPRING SET, DEMCO/DICO FREE-BACKING (QTY 3)	3A
BP08-080	220200	ADJUSTER SPRING, BENDIX, DEXTER, DEMCO/DICO	4
BP08-110	220350	ADJUSTER SPRING, ATWOOD	4
BP10-050	222200	ADJUSTER, ATWOOD	5
BP10-060	222400	ADJUSTER, DEXTER, DEMCO/DICO	5
BP10-080	222800	ADJUSTER, BENDIX	5
BP10-220	225100	ADJUSTER DUST PLUG, (ALL) PKG OF 4	6
BP17-020	233200	WHEEL CYLINDER ASSEMBLY, RH	7
BP17-030	233400	WHEEL CYLINDER ASSEMBLY, LH	7



## 12" x 2" Single-Servo Hydraulic



Standard Single-Servo



Dexter Free-backing



Demco/Dico Free-backing

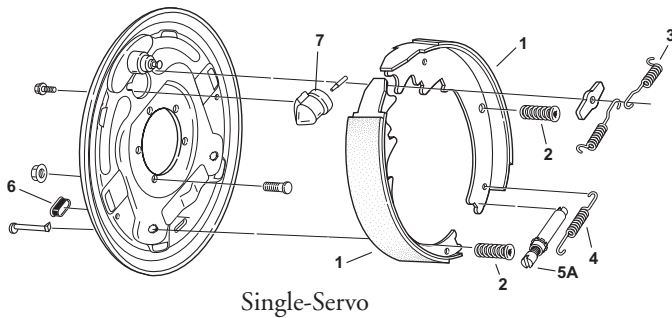

Single-Servo

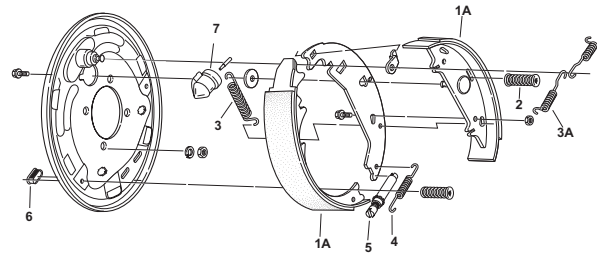

Free-Backing

BRAKE  
ASSEMBLIES

### 12" x 2" Single-Servo Hydraulic Brake Assemblies

- Choose from Standard Single Servo or Free-backing versions (Duo-Servo on next page)

Part No.	Ref. No.	Description	Capacity Per Pair
23-324	175425	LEFT BRAKE - DEXTER (SHOWN IN PHOTO)	5,200
23-325	175450	RIGHT BRAKE - DEXTER	5,200
23-338	175460	LEFT BRAKE - DEXTER	7,000
23-339	175465	RIGHT BRAKE - DEXTER	7,000
23-342	175500	LEFT BRAKE, FREE-BACKING - DEXTER (SHOWN IN PHOTO)	7,000
23-343	175550	RIGHT BRAKE, FREE-BACKING - DEXTER	7,000
23510	175350	RIGHT BRAKE- DEMCO/DICO	6,000
23511	175400	LEFT BRAKE - DEMCO/DICO	6,000
42028	175470	RIGHT BRAKE, FREE-BACKING - DEMCO/DICO (SHOWN IN PHOTO)	6,000
42029	175480	LEFT BRAKE, FREE-BACKING - DEMCO/DICO	6,000



### Replacement Parts

Part No.	Ref. No.	Description	Item
BP04-160	206000	SHOE AND LINING (ONE WHEEL)	1
BP04-162	206100	SHOE AND LINING (ONE WHEEL), RIGHT HAND DEXTER FREE-BACKING	1A
BP04-164	206200	SHOE AND LINING (ONE WHEEL), LEFT HAND DEXTER FREE-BACKING	1A
BP04-168	206300	SHOE AND LINING (ONE WHEEL), DEMCO/DICO FREE-BACKING	1A
BP06-090	212400	SHOE HOLD DOWN SPRINGS	2
BP07-121	216830	PRIMARY SHOE RETURN SPRING SET (UPPER & LOWER), DEXTER FREE-BACKING (QTY 3)	3A
BP07-123	216850	PRIMARY SHOE RETURN SPRING SET (UPPER & LOWER), DEMCO/DICO FREE-BACKING (QTY 3)	3A
BP07-175	217700	SHOE RETURN SPRINGS	3
BP08-120	220400	ADJUSTER SPRING	4
BP10-080	222800	ADJUSTER, DEXTER FREEBACKING, DEMCO/DICO, BENDIX	5
BP10-045	222100	ADJUSTER, DEXTER	5A
BP10-220	225100	ADJUSTER DUST PLUG, (ALL), PKG OF 4	6
BP17-020	233200	WHEEL CYLINDER ASSEMBLY, RIGHT HAND, SINGLE-SERVO	N/S
BP17-030	233400	WHEEL CYLINDER ASSEMBLY, LEFT HAND, SINGLE-SERVO	7

## 12" x 2" Duo-Servo Hydraulic

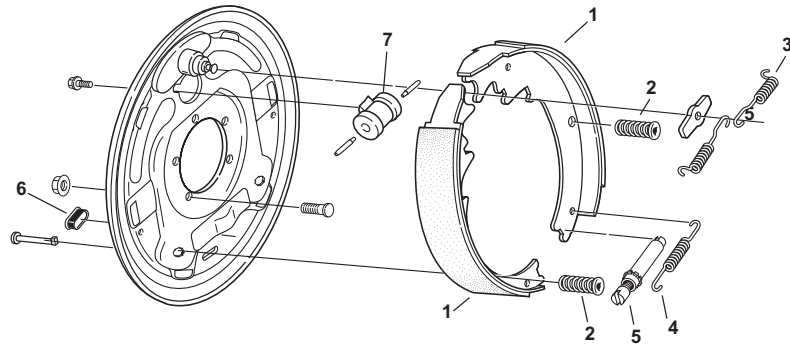

BRAKE ASSEMBLIES

### 12" x 2" Duo-Servo Hydraulic Brake Assemblies

• Duo-Servo		
Part No.	Ref. No.	Description
23-322	176225	LEFT BRAKE (SHOWN IN PHOTO) 5,200 LB CAPACITY
23-323	176250	RIGHT BRAKE 5,200 LB CAPACITY
23-337	176550	RIGHT BRAKE, 6,000 LB CAPACITY
23-336	176500	LEFT BRAKE, 6,000 LB CAPACITY



### Replacement Parts

Part No.	Ref. No.	Description	Item
BP04-160	206000	SHOE AND LINING (ONE WHEEL)	1
BP06-090	212400	SHOE HOLD DOWN SPRINGS	2
BP07-175	217700	SHOE RETURN SPRING	3
BP08-120	220400	ADJUSTER SPRING	4
BP10-045	222100	ADJUSTER, DEXTER	5
BP10-220	225100	ADJUSTER DUST PLUG (ALL), PKG OF 4	6
BP17-040	233600	WHEEL CYLINDER ASSEMBLY, RIGHT HAND, DUO-SERVO	7
BP17-050	233800	WHEEL CYLINDER ASSEMBLY, LEFT HAND, DUO-SERVO	7

## Bendix 12" x 3" Duo Servo Hydraulic

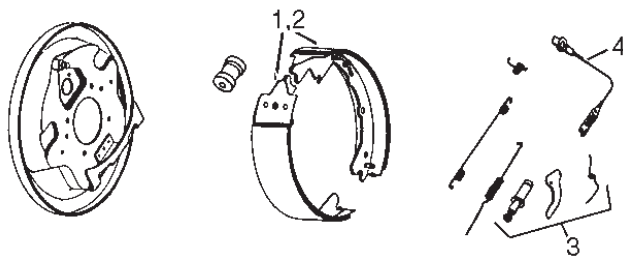

### Bendix 12" x 3" Duo-Servo Hydraulic Brake Assemblies

• Duo-Servo		
• Capacity: 7,500 lbs. per pair		
Part No.	Ref. No.	Description
3203933	176800	LEFT BRAKE (SHOWN IN PHOTO)
3203934	177000	RIGHT BRAKE



### Replacement Parts

Part No.	Ref. No.	Description	Item
BP04-200	206800	SHOE AND LINING (ONE WHEEL), LEFT HAND	1
BP04-210	207000	SHOE AND LINING (ONE WHEEL), RIGHT HAND	2
BP10-135	223700	ADJUSTER, LEVER AND SPRING, LEFT HAND	3
BP10-145	223900	ADJUSTER, LEVER AND SPRING, RIGHT HAND	3
BP13-023	225500	ADJUSTER CABLE AND RETAINER	4



## Hayes 12" x 3 1/4" Duo-Servo Hydraulic

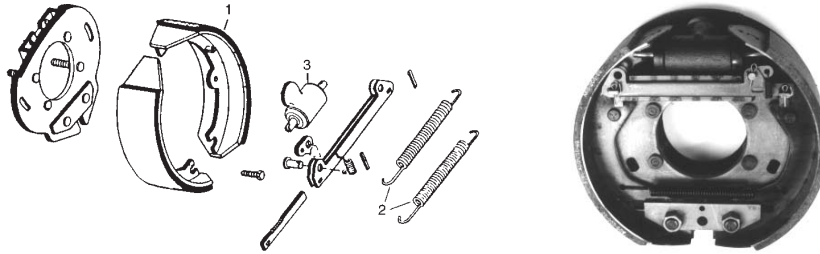

### Hayes 12" x 3 1/4" Duo-Servo Hydraulic Brake Assemblies

- Duo-Servo
- Capacity: 8,000 lbs. per pair

Part No.	Ref. No.	Description
60206803	177200	LEFT OR RIGHT BRAKE

### Replacement Parts

Part No.	Ref. No.	Description	Item
BP04-230	208000	SHOE AND LINING (ONE WHEEL)	1
BP07-215	218700	SHOE RETURN SPRINGS (QTY 2)	2
BP17-080	234400	WHEEL CYLINDER ASSEMBLY, LEFT HAND OR RIGHT HAND	3



BRAKE  
ASSEMBLIES

## Dexter 12 1/4" x 3 3/8" Duo-Servo Hydraulic, 4 Bolt Flange

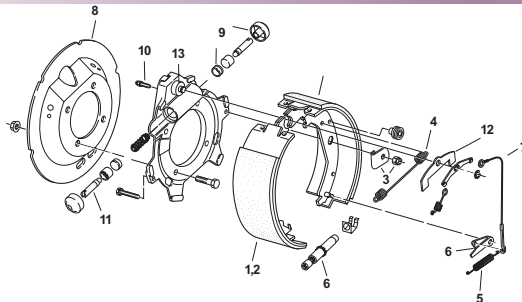

### Dexter 12 1/4" x 3 3/8" Duo-Servo Hydraulic Brake Assemblies

- Duo-Servo
- Capacity: 9,000 lbs. per pair (Dexter 9,000 lb. before 10/1/89, all 8,000 lb.)
- Redesigned with forward adjust feature in 1997.

Part No.	Ref. No.	Description
23-402	178205	LEFT BRAKE (SHOWN IN PHOTO) 9K (4 BOLT)
23-403	178210	RIGHT BRAKE, 9K (4 BOLT)

### Replacement Parts

Part No.	Ref. No.	Description	Item
BP04-260	208600	SHOE AND LINING (ONE WHEEL), LEFT HAND	1
BP04-270	208800	SHOE AND LINING (ONE WHEEL), RIGHT HAND	2
BP06-235	214300	SHOE HOLD DOWN KIT (QTY 2)	3
BP07-240	219200	SHOE RETURN SPRING	4
BP08-150	220900	ADJUSTER SPRING	5
BP10-135	223700	ADJUSTER, LEVER AND SPRING, LEFT HAND	6
BP10-145	223900	ADJUSTER, LEVER AND SPRING, RIGHT HAND	6
BP10-150	223950	ADJUSTER KIT FOR FORWARD ADJUST BRAKES LH	6,7
BP10-160	223960	ADJUSTER KIT FOR FORWARD ADJUST BRAKES RH	6,7
BP13-023	225500	ADJUSTER CABLE AND RETAINER, BEFORE 1987 (14.25" LONG)	7
BP13-033	225610	ADJUSTER CABLE AND RETAINER, 1987-1996 (14" LONG)	7
BP15-015	227700	BRAKE DUST SHIELD (ONE PIECE) 8,000 LBS. (4 BOLT)	8
BP16-040	232400	WHEEL CYLINDER REBUILD KIT (1.00" BORE)	9
BP18-011	234810	BLEEDER SCREW (QTY 4)	10
BP18-021	235010	CYLINDER PUSH ROD (QTY 4)	11
BP18-025	235025	PISTON STOP BAR, AFTER 1987	12
BP18-040	235400	BRAKE SHOE ANCHOR PIN	13



## Dexter 12 1/4" x 3 3/8" Duo-Servo Hydraulic, 7 Bolt Flange

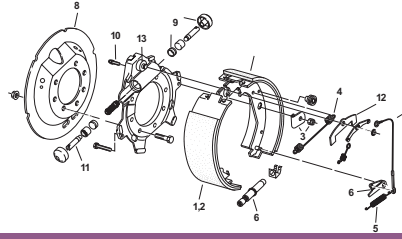

### Dexter 12 1/4" x 3 3/8" Duo-Servo Hydraulic Brake Assemblies

- Duo-Servo
- Capacity: 10,000 lbs. per pair (fits Dexter 9k after 1989).
- Redesigned with forward adjust feature in February 1997.

Part No.	Ref. No.	Description
23-410	178275	LEFT BRAKE (SHOWN IN PHOTO), 9K (AFTER 10/89), 10K GEN. DUTY (7 BOLT)
23-411	178300	RIGHT BRAKE , 9K (AFTER 10/89), 10K GEN. DUTY (7 BOLT)

### Replacement Parts

Part No.	Ref. No.	Description	Item
BP04-260	208600	SHOE AND LINING (ONE WHEEL), LEFT HAND	1
BP04-270	208800	SHOE AND LINING (ONE WHEEL), RIGHT HAND	2
BP06-235	214300	SHOE HOLD DOWN KIT (QTY 2)	3
BP07-240	219200	SHOE RETURN SPRING	4
BP08-150	220900	ADJUSTER SPRING	5
BP10-135	223700	ADJUSTER, LEVER AND SPRING, LEFT HAND	6
BP10-145	223900	ADJUSTER, LEVER AND SPRING, RIGHT HAND	6
BP10-150	223950	ADJUSTER KIT FOR FORWARD SELF ADJUST BRAKE LH	6,7
BP10-160	223960	ADJUSTER KIT FOR FORWARD SELF ADJUST BRAKE RH	6,7
BP13-023	225500	ADJUSTER CABLE AND RETAINER, BEFORE 1987 (14.25" LONG)	7
BP13-033	225610	ADJUSTER CABLE AND RETAINER, 1987-1996 (14" LONG)	7
BP15-085	229100	BRAKE DUST SHIELD 7 BOLT (ONE-PIECE) METAL	8
BP16-050	232600	WHEEL CYLINDER REBUILD KIT (1.25" BORE)	9
BP18-011	234810	BLEEDER SCREW (QTY 4)	10
BP18-021	235010	CYLINDER PUSH ROD (QTY 4)	11
BP18-025	235025	PISTON STOP BAR, AFTER 1987	12
BP18-040	235400	BRAKE SHOE ANCHOR PIN	13

## Hayes 12 1/4" x 3 1/2" Duo-Servo Hydraulic

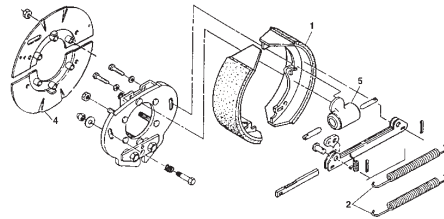

### Hayes 12 1/4" x 3 1/2" Duo-Servo Hydraulic Brake Assemblies

- Duo-Servo
- Capacity: 12,000 lbs. per pair

Part No.	Ref. No.	Description
60206801	177800	LEFT OR RIGHT BRAKE (SHOWN IN PHOTO)

### Replacement Parts

Part No.	Ref. No.	Description	Item
BP04-300	209400	SHOE AND LINING (ONE WHEEL)	1
BP07-215	218700	SHOE RETURN SPRINGS (QTY 2)	2
BP15-100	229400	BRAKE DUST SHIELD (LOWER)	4
BP17-090	234600	WHEEL CYLINDER ASSEMBLY, LEFT OR RIGHT HAND	5



## Dexter 12 1/4" x 4" Duo-Servo Hydraulic

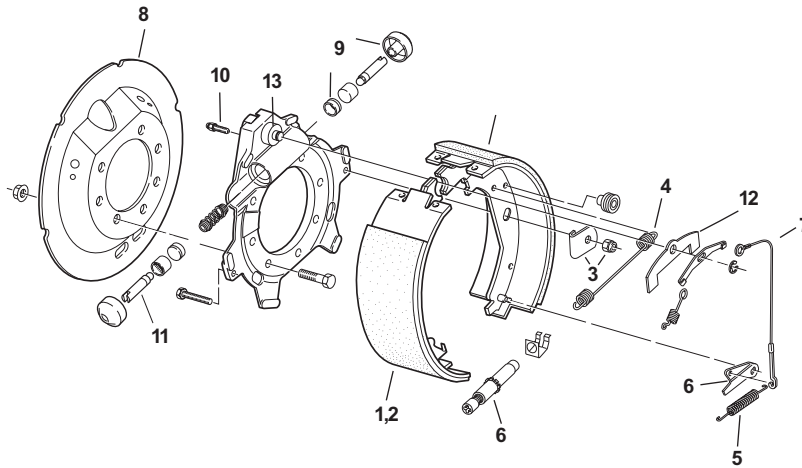

BRAKE  
ASSEMBLIES

### Dexter 12 1/4" x 4" Duo-Servo Hydraulic Brake Assemblies

- Duo-Servo
- Capacity: 10,000 lbs. per pair
- Redesigned with forward adjust feature in 1997

Part No.	Ref. No.	Description
23-404	179100	LEFT BRAKE (SHOWN IN PHOTO)
23-405	179150	RIGHT BRAKE

### Replacement Parts

Part No.	Ref. No.	Description	Item
BP04-340	210000	SHOE AND LINING (ONE WHEEL), LEFT HAND	1
BP04-350	210200	SHOE AND LINING (ONE WHEEL), RIGHT HAND	2
BP06-235	214300	SHOE HOLD DOWN KIT (QTY 2)	3
BP07-240	219200	SHOE RETURN SPRING	4
BP08-150	220900	ADJUSTER SPRING	5
BP10-135	223700	ADJUSTER, LEVER AND SPRING, LEFT HAND	6
BP10-145	223900	ADJUSTER, LEVER AND SPRING, RIGHT HAND	6
BP10-150	223950	ADJUSTER KIT FOR FORWARD SELF-ADJUST BRAKE, LH	6,7
BP10-160	223960	ADJUSTER KIT FOR FORWARD SELF-ADJUST BRAKE RH	6,7
BP13-023	225500	ADJUSTER CABLE AND RETAINER, BEFORE 1987 (14.25" LONG)	7
BP13-033	225610	ADJUSTER CABLE AND RETAINER 1987-1996 (14" LONG)	7
BP15-150	230300	BRAKE DUST SHIELD 7 BOLT (ONE-PIECE) METAL	8
BP16-050	232600	WHEEL CYLINDER REBUILD KIT (1.250" BORE)	9
BP18-011	234810	BLEEDER SCREW (QTY 4)	10
BP18-021	235010	CYLINDER PUSH ROD (QTY 4)	11
BP18-025	235025	PISTON STOP BAR, AFTER 1987	12
BP18-040	235400	BRAKE SHOE ANCHOR PIN	13

## Dexter 12 1/4" x 5" Duo-Servo Hydraulic

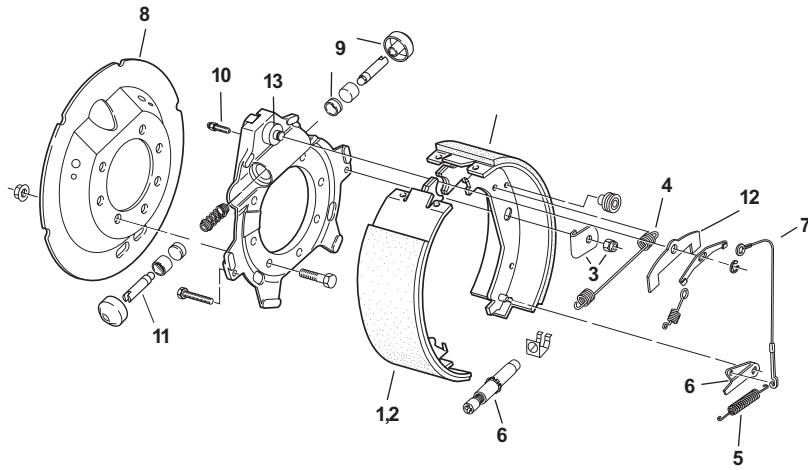

BRAKE ASSEMBLIES

### Dexter 12 1/4" x 5" Duo-Servo Hydraulic Brake Assemblies

- Capacity: 12,000 and 15,000 lbs. per pair
- Redesigned with forward adjust feature in 1997.

Part No.	Ref. No.	Description
23-408	179825	LEFT BRAKE (SHOWN IN PHOTO), 12,000 LB
23-409	179850	RIGHT BRAKE, 12,000 LB
23-406	180250	LEFT BRAKE, 15,000 LB
23-407	180300	RIGHT BRAKE, 15,000 LB

### Replacement Parts

Part No.	Ref. No.	Description	Item
BP04-380	210800	SHOE AND LINING (ONE WHEEL), LEFT HAND	1
BP04-390	211000	SHOE AND LINING (ONE WHEEL), RIGHT HAND	2
BP06-235	214300	SHOE HOLD DOWN WASHER AND NUT (QTY 2)	3
BP07-240	219200	SHOE RETURN SPRING	4
BP08-150	220900	ADJUSTER SPRING	5
BP10-135	223700	ADJUSTER, LEVER AND SPRING, LEFT HAND	6
BP10-145	223900	ADJUSTER, LEVER AND SPRING, RIGHT HAND	6
BP10-150	223950	ADJUSTER KIT FOR FORWARD SELF-ADJUST BRAKE LH	6,7
BP10-160	223960	ADJUSTER KIT FOR FORWARD SELF-ADJUST BRAKE RH	6,7
BP13-023	225500	ADJUSTER CABLE AND RETAINER, BEFORE 1987 (14.25" LONG)	7
BP13-033	225610	ADJUSTER CABLE AND RETAINER, 1987-1996 (14" LONG)	7
BP15-190	231100	BRAKE DUST SHIELD 7 BOLT (ONE-PIECE) METAL	8
BP16-050	232600	WHEEL CYLINDER REBUILD KIT, 12,000 LBS (1.250" BORE)	9
BP16-060	232625	WHEEL CYLINDER REBUILD KIT, 15,000 LBS (1.375" BORE)	9
BP18-011	234810	BLEEDER SCREW (QTY 4)	10
BP18-021	235010	CYLINDER PUSH ROD (QTY 4)	11
BP18-025	235025	PISTON STOP BAR, AFTER 1987	12
BP18-040	235400	BRAKE SHOE ANCHOR PIN	13

## Replacement Parts for Dexter 10K and 12K Hydraulic Disc Brakes

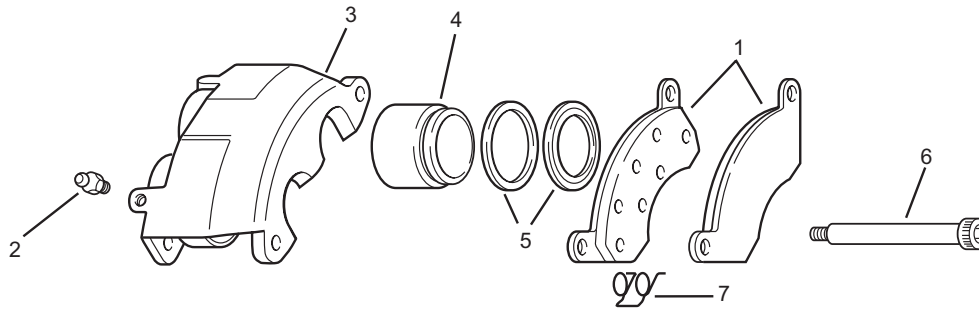

BRAKE  
ASSEMBLIES

### Replacement Parts for Dexter 10,000 lb. and 12,000 lb. Hydraulic Disc Brakes

• Capacity: 12,000 lbs. per pair

Part No.	Ref. No.	Description	Item
BP04-395	211100	DISC BRAKE PAD AND LINING (ONE WHEEL) 10,000 & 12,000 LB	1
BP18-016	234850	BLEEDER SCREW, 10,000 & 12,000 LB (QTY 4)	2
BP18-045	235425	DISC BRAKE CALIPER 10,000 & 12,000 LB	3
BP18-065	235975	DISC BRAKE CALIPER PISTON, 10,000 & 12,000 LB	4
BP18-075	236050	DISC BRAKE CALIPER REBUILD KIT, 10,000 & 12,000 LB	5
BP18-105	236430	CALIPER RETAINING SHOULDER BOLT, 5/8" x 5.00", 10,000 AND 12,000 LB (ONE WHEEL)	6
BP18-115	236460	DISC BRAKE PAD ANTI-RATTLE SPRING, 10,000 AND 12,000 LB (ONE WHEEL)	7

## Replacement Parts for Hayes 10K and 12K Hydraulic Disc Brakes

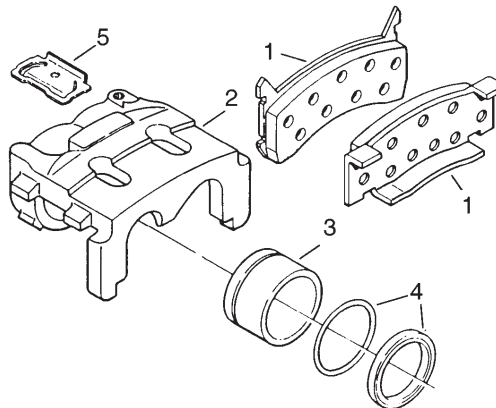

### Replacement Parts for Hayes 10,000 lb. and 12,000 lb. Hydraulic Disc Brakes

• Capacity: 12,000 lbs. per pair

Part No.	Ref. No.	Description	Item
BP04-400	211200	DISC BRAKE PAD AND LINING (ONE WHEEL) 10,000 & 12,000 LB	1
BP18-050	235600	DISC BRAKE CALIPER, LEFT HAND, 10,000 & 12,000 LB	2
BP18-060	235800	DISC BRAKE CALIPER, RIGHT HAND, 10,000 & 12,000 LB	2
BP18-070	236000	DISC BRAKE CALIPER PISTON, 10,000 & 12,000 LB	3
BP18-080	236200	DISC BRAKE CALIPER REBUILD KIT, 10,000 & 12,000 LB	4
BP18-090	236400	DISC BRAKE PAD RETAINER PLATE, 10,000 & 12,000 LB	5

**Miscellaneous Air Brake Replacement Parts for Dexter Air Brakes**

BRAKE  
ASSEMBLIES

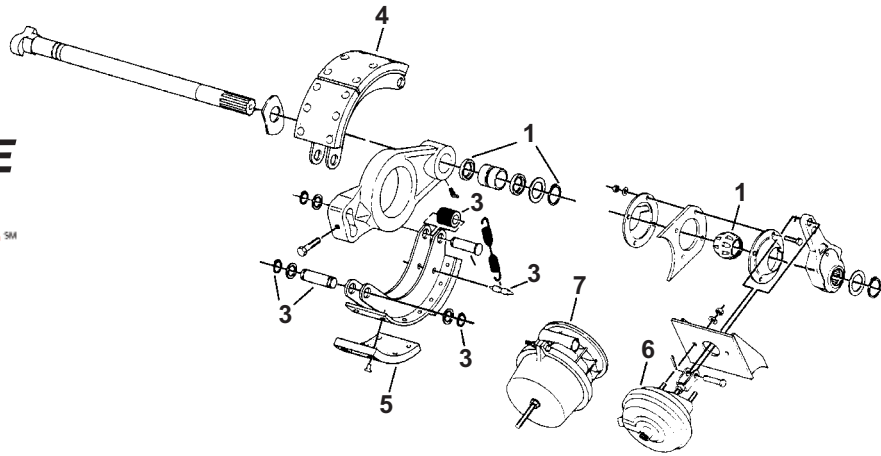

Part No.	Ref. No.	Description	Item
BP15-220	231625	BRAKE DUST SHIELD 16 1/2" X 7" AIR BRAKE (2 PC)	N/S
BP20-090	240800	CAMSHAFT REPAIR KIT FOR 12 1/4" DEXTER AIR BRAKES INCLUDES WASHERS, SEALS AND BUSHINGS	1
BP20-120	241400	BRAKE SHOE REPAIR KIT FOR 12 1/4" DEXTER AIR BRAKES INCLUDES ROLLERS, ANCHOR PINS, ETC, OLD STYLE	3
BP20-130	241425	BRAKE SHOE REPAIR KIT FOR 16 1/2" Q STYLE DEXTER AIR BRAKES INCLUDES ROLLERS, ANCHOR PINS, ETC.	N/S
BP20-135	241450	BRAKE SHOE REPAIR KIT W/ROLLERS, ANCHOR PINS, FOR DEXTER 12 1/4" PQ SHOES	N/S
BP22-010	243200	SHOE WITH LINING (2 PER WHEEL REQUIRED) FOR 12 1/4" x 4" OLD STYLE	4A
BP22-015	243300	SHOE WITH LINING (2 PER WHEEL REQUIRED) FOR 12 1/4" X 4" DEXTER AIR BRAKE "PQ-STYLE"	4B
BP22-020	243400	SHOE WITH LINING (2 PER WHEEL REQUIRED) FOR 12 1/4" x 5" OLD STYLE	4A
BP22-025	243500	SHOE WITH LINING (2 PER WHEEL REQUIRED) FOR 12 1/4" X 5" DEXTER AIR BRAKE "PQ-STYLE"	4B
BP22-035	243650	SHOE WITH LINING (2 PER WHEEL REQUIRED) FOR 12 1/4" X 7 1/2" DEXTER AIR BRAKE "PQ-STYLE"	4B
BP24-010	245800	REP'L LININGS, (1 WHEEL) 12 1/4" X 4"	5
BP24-020	246000	REP'L LININGS, (1 WHEEL) 12 1/4" X 5"	5
BP25-010	246600	AIR CHAMBER, TYPE 16, FOR 12 1/4 x 4" AIR BRAKE	6
BP25-020	246800	AIR CHAMBER, TYPE 24, FOR 12 1/4" x 7 1/2" AIR BRAKE	6
BP25-030	247000	AIR CHAMBER, TYPE 30, FOR 12 1/4" OR 16 1/2" AIR BRAKE	6
BP26-010	247200	SPRING BRAKE CHAMBER, TYPE 16/24 COMBINATION	7
BP26-020	247400	SPRING BRAKE CHAMBER, TYPE 24/30 COMBINATION	7
BP26-030	247600	SPRING BRAKE CHAMBER, TYPE 30/30 COMBINATION	7

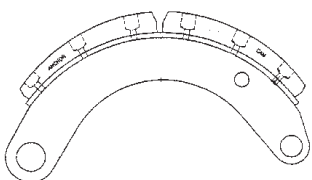

"Old Style" 4A

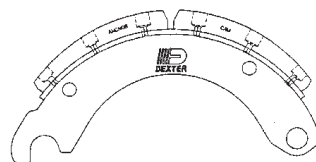

"PQ Style" 4B

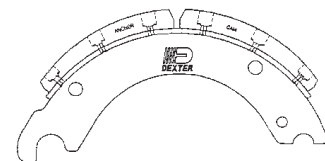

"Q Style"



## Suspensions

Single Axle Hanger Kits for 2,000 lb. - 7,000 lb. Axles (Double Eye Springs)	D-2	Suspension Bushings	D-15
Tandem Axle Hanger Kits for 2,000 - 7,000 lb. Axles (Double Eye Springs)	D-3	Spring Center Tie Bolts	D-15
Single Axle Hanger Kits for 3,500 lb. - 8,000 lb. Axles(2" Slipper Springs)	D-3	U-Bolt Kits	D-15
Single Axle Hanger Kit for "WI" Series, 1 3/4" wide, Slipper Springs w/9/16" Eye	D-3	U-Bolt Kits	D-16
Tandem Axle Hanger Kits for 2,000 - 7,000 lb. Axles (Double Eye Springs)	D-4	Replacement U-Bolts - Square End	D-16
Tandem Axle Hanger Kits for 2,000 - 7,000 lb. Axles (Double Eye Springs)	D-5	Replacement U-Bolts - Round End	D-16
Tandem Axle Hanger Kits for 3,500 - 8,000 lb. Axles (Slipper Springs)	D-6	U-Bolts Nuts and Lockwashers	D-17
Combination Kits	D-7	Shackle Straps	D-17
Triple Axle Hanger Kits for 2,000 - 7,000 lb. Axles(Double Eye Springs)	D-7	U-Bolt Axle Plates	D-17
Triple Axle Hanger Kits for 2,000 - 7,000 lb. Axles(Slipper Springs)	D-8	Hangers for 2 1/2" Slipper Springs	D-18
Multi-Axle Conversion Kits for 9,000 lb. Axles	D-9	Hangers for 2" Slipper Springs	D-18
Single Axle Hanger & Attaching Parts Kit for 9,000 lb. Axles (Slipper Springs)	D-9	Hangers for Double Eye Springs	D-18
Multi-Axle Conversion Kits for 10,000 lb. General Duty Axles	D-10	Hanger for "WI" Series Springs	D-18
Single Axle Hanger and Attaching Parts Kits for 10,000 lb.	D-10	Equalizer for 2" Slipper Springs	D-19
General Duty Axles (Slipper Springs)	D-10	Short Curved Equalizer	D-19
Single Axle Hanger Kit for 10,000 - 15,000 lb. Axles (Slipper Springs)	D-11	Curved Equalizers	D-19
Multi-Axle Conversion Kits for 10,000 lb. - 15,000 lb. Axles	D-11	Tall Triangular Equalizer	D-19
Slipper Springs	D-14	Straight Equalizers	D-19
Double Eye Springs	D-14	Hangers for 3" Slipper Springs	D-19
		Cotter Pins and Grease Zerks	D-20
		Equalizers for Hayes 2 1/2" Slipper Springs	D-20
		Equalizers for 3" Slipper Springs	D-20
		Equalizers for 2 1/2" Slipper Springs	D-20
		Equalizers for 2" Slipper Springs	D-20
		Suspension Nuts	D-21
		Suspension Bolts	D-21
		Popular Suspension Bolts with Nuts	D-21
		Suspension Replacement Parts	D-22
		Hutch Heavy Duty Suspensions	D-23
		Ridewell Air-Ride Trailer Suspensions	D-24
		Red Rider Air Ride Suspension	D-25
		Ride-Rite Air Helper Springs	D-26

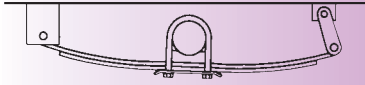

## Single Axle Hanger Kits for 2,000 lb. - 7,000 lb. Axles (Double Eye Springs)

### APS1

Hanger Kit for 2,000 - 3,500 lb. axles with double eye springs uses a 1 1/2" tall front hanger, 3 1/8" long shackle strap and .91" rear hanger with steel sleeve.

Part No.	Ref. No.	Description	Qty
APS1	025800	COMPLETE HANGER KIT - INCLUDES THE FOLLOWING:	
115917	089400	FRONT HANGER, 1 1/2" TALL	2
30-20	089200	REAR HANGER	2
115208	102000	SHACKLE STRAP, 3 1/8" CENTER OF HOLE	4
9163B	095600	SHACKLE BOLT, 9/16" x 3"	6
916DLN	096800	9/16" HEXLOCKNUT	6

### APS2

Hanger Kit for 2,000 - 3,500 lb. axles with double eye springs uses a 1 1/2" tall front hanger, 2 5/8" long shackle strap and 1 1/2" rear hanger without bushing.

Part No.	Ref. No.	Description	Qty
APS2	025810	COMPLETE HANGER KIT - INCLUDES THE FOLLOWING:	
115917	089400	FRONT HANGER, 1 1/2" TALL	2
93003-3X	089150	REAR HANGER	2
115052	101800	SHACKLE STRAP 2 5/8" CENTER OF HOLE	4
9163B	095600	SHACKLE BOLT, 9/16" x 3"	6
916DLN	096800	9/16" HEXLOCKNUT	6

### APS3

Hanger Kit for 2,000 - 3,500 lb. axles with double eye springs uses a 1 1/2" tall front hanger, 3 1/8" long shackle strap and 1 1/2" rear hanger without bushing.

Part No.	Ref. No.	Description	Qty
APS3	025825	COMPLETE HANGER KIT - INCLUDES THE FOLLOWING:	
115917	089400	FRONT HANGER, 1 1/2" TALL	2
93003-3X	089150	REAR HANGER	2
115208	102000	SHACKLE STRAP, 3 1/8" CENTER OF HOLE	4
9163B	095600	SHACKLE BOLT, 9/16" x 3"	6
916DLN	096800	9/16" HEXLOCKNUT	6

### APS4

Hanger Kit for 2,000 - 3,500 lb. axles with double eye springs uses a 3 1/4" tall front hanger, 3 1/8" long shackle strap and 1 1/2" rear hanger without bushing.

Part No.	Ref. No.	Description	Qty
APS4	025850	COMPLETE HANGER KIT - INCLUDES THE FOLLOWING:	
28-5	089800	FRONT HANGER, 3 1/4" TALL	2
93003-3X	089150	REAR HANGER	2
115208	102000	SHACKLE STRAP, 3 1/8" CENTER OF HOLE	4
9163B	095600	SHACKLE BOLT, 9/16" x 3"	6
916DLN	096800	9/16" HEXLOCKNUT	6

### APS5

Hanger Kit for 2,000 - 7,000 lb. axles with double eye springs uses a 3 1/4" tall front hanger, 3 1/8" long shackle strap and a .91" rear hanger with bushing.

Part No.	Ref. No.	Description	Qty
APS5	026000	COMPLETE HANGER KIT - INCLUDES THE FOLLOWING:	
28-5	089800	FRONT HANGER, 3 1/4" TALL	2
30-20	089200	REAR HANGER	2
115208	102000	SHACKLE STRAP, 3 1/8" CENTER OF HOLE	4
9163B	095600	SHACKLE BOLT, 9/16" x 3"	6
916DLN	096800	9/16"-HEXLOCKNUT	6

SEE PAGE D-12 & D-13 FOR HANGER LOCATIONS AND OTHER SPECIFICATIONS



### Single Axle Hanger Kit for "WI" Series, 1 3/4" wide, Slipper Springs w/9/16" Eye

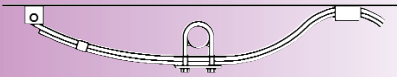

Part No.	Ref. No.	Description	Qty
APS3SE	026300	COMPLETE HANGER KIT - INCLUDES THE FOLLOWING:	
115917	089400	FRONT HANGER, 1 1/2" TALL	2
115706S	088800	REAR HANGER	2
9163B	095600	SHACKLE BOLT 9/16" X 3"	2
916DLN	096800	9/16" HEX LOCK NUT	2

#### APS3SE

Hanger Kit for 2,000 lb. axles with 1 3/4" wide "WI" series slipper springs uses a 1 1/2" tall front hanger and a "spring clip" as a rear hanger.

### Single Axle Hanger Kits for 3,500 lb. - 8,000 lb. Axles (2" Slipper Springs)

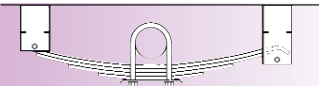

Part No.	Ref. No.	Description	Qty
APS6SE	026400	COMPLETE HANGER KIT - INCLUDES THE FOLLOWING:	
721584	091200	FRONT HANGER, 3 3/4" TALL	2
721585	091600	REAR HANGER, 5 1/16" TALL	2
91635B	096400	SHACKLE BOLT, 9/16" x 3 1/2"	4
916DLN	096800	9/16"HEXLOCKNUT	4

#### APS6SE

Hanger Kit for 3,500 - 8,000 lb. axles with 2" wide slipper springs uses heavy duty 3 3/4" tall front hanger and 5 1/16" tall rear hanger.

### Tandem Axle Hanger Kits for 2,000 - 7,000 lb. Axles (Double Eye Springs)



Part No.	Ref. No.	Description	Qty
APT1	026600	COMPLETE HANGER KIT -- INCLUDES THE FOLLOWING:	
115919	090400	CENTER HANGER, 5 7/16" TALL, 3/4" HOLE	2
115918	089600	END HANGER, 2 1/2" TALL	4
A2251B3	082400	EQUALIZER BAR, 8" LONG, STRAIGHT (2) 9/16" AND (1) 3/4" HOLES	2
115052	101800	SHACKLE STRAP, 2 5/8" CENTER OF HOLE	8
9163B	095600	SHACKLE BOLT, 9/16" x 3"	12
916DLN	096800	9/16"HEXLOCKNUT	12
126A1LN	097000	WET EQUALIZER BOLT, 3/4" x 3 1/2"	2
165093	097400	3/4" NUT FOR EQUALIZER BOLT	2
165649	101200	COTTER PIN, 2 1/4" OVERALL	2
1610	101400	1/4" STRAIGHT GREASE ZERK WITH 1/8" M.P.T.	2

#### APT1

For 2,000 - 7,000 lb. axles with double eye springs uses 8" straight equalizer and 3/4" greaseable equalizer bolt, 2 1/2" tall end hangers and a 5 7/16" tall center hanger.

Part No.	Ref. No.	Description	Qty
APT3	026800	COMPLETE HANGER KIT - INCLUDES THE FOLLOWING:	
115918	089600	CENTER HANGER, 2 1/2" TALL	2
115917	089400	END HANGER, 1 1/2" TALL	4
A2252CB	083400	EQUALIZER BAR, 7 3/4" LONG, CURVED, 9/16" ALL 3 HOLES	2
115052	101800	SHACKLE STRAP, 2 5/8" CENTER OF HOLE	8
9163B	095600	SHACKLE BOLT, 9/16" x 3"	14
916DLN	096800	9/16"HEXLOCKNUT	14

#### APT3

For 2,000 - 7,000 lb. axles with double eye springs uses 7 3/4" curved equalizer, 1 1/2" tall end hangers and a 2 1/2" tall center hanger.

SEE PAGE D-12 & D-13 FOR HANGER LOCATIONS AND OTHER SPECIFICATIONS

**Tandem Axle Hanger Kits for 2,000 - 7,000 lb. Axles  
(Double Eye Springs)**



**APT3HD**

For 2,000 - 7,000 lb. axles with double eye springs uses 7 3/4" long curved equalizer, 2 1/2" tall end hangers and a 5 7/16" tall center hanger.

Part No.	Ref. No.	Description	Qty
APT3HD	026815	COMPLETE HANGER KIT - INCLUDES THE FOLLOWING:	
115918	089600	END HANGER, 2 1/2" TALL	4
115919	090400	CENTER HANGER, 5 7/16" TALL, 3/4" HOLE	2
A2252CB34	083600	EQUALIZER BAR, 7 3/4" LONG, CURVED 9/16" F & R, 3/4" CENTER HOLES	2
115052	101800	SHACKLE STRAP, 2 5/8" CENTER OF HOLE	8
9163B	095600	SHACKLE BOLT, 9/16" X 3"	12
916DLN	096800	9/16" HEXLOCKNUT	12
126A1LN	097000	WET EQUALIZER BOLT, 3/4" X 3 1/2"	2
165093	097400	3/4" NUT FOR EQUALIZER BOLT	2
165649	101200	COTTER PIN, 2 1/4" OVERALL	2
1610	101400	1/4" STRAIGHT GREASE ZERK WITH 1/8" M.P.T.	2

**APT4**

For 2,000 - 7,000 lb. axles with double eye springs uses 6 1/4" curved equalizer and 3/4" greaseable pivot bolt, 3 1/4" tall front and rear hangers and a 5 7/16" tall center hanger.

Part No.	Ref. No.	Description	Qty
APT4	027000	COMPLETE HANGER KIT - INCLUDES THE FOLLOWING:	
115919	090400	CENTER HANGER, 5 7/16" TALL, 3/4" HOLE	2
28-5	089800	END HANGER, 3 1/4" TALL	4
220AIT3B	083200	EQUALIZER BAR, 6 1/4", CURVED, 3/4" CENTER HOLE, 9/16" END HOLES	2
115052	101800	SHACKLE STRAP, 2 5/8" CENTER OF HOLE	8
9163B	095600	SHACKLE BOLT, 9/16" x 3"	12
916DLN	096800	9/16" HEXLOCKNUT	12
126A1LN	097000	WET EQUALIZER BOLT, 3/4" x 3 1/2"	2
165093	097400	3/4" NUT FOR EQUALIZER BOLT	2
165649	101200	COTTER PIN, 2 1/4" OVERALL	2
1610	101400	1/4" STRAIGHT GREASE ZERK WITH 1/8" M.P.T.	2

**APT5**

For 2,000 - 7,000 lb. axles with double eye springs uses 7 3/4" curved equalizers and 3 1/4" tall hangers in front, center and rear.

Part No.	Ref. No.	Description	Qty
APT5	027200	COMPLETE HANGER KIT - INCLUDES THE FOLLOWING:	
28-5	089800	FRONT, CENTER AND END HANGER, 3 1/4" TALL	6
A2252CB	083400	EQUALIZER BAR, 7 3/4" LONG, CURVED, 9/16" ALL HOLES	2
115052	101800	SHACKLE STRAP, 2 5/8" CENTER OF HOLE	8
9163B	095600	SHACKLE BOLT, 9/16" x 3"	14
916DLN	096800	9/16" HEX LOCKNUT	14

**APT7**

For 2,000 - 7,000 lb. axles with double eye springs uses 7 3/4" long curved equalizer, 1/2" tall front and rear hanger and a 3 1/4" tall center hanger.

Part No.	Ref. No.	Description	Qty
APT7	027210	COMPLETE HANGER KIT - INCLUDES THE FOLLOWING:	
115918	089600	FRONT & REAR HANGER, 2 1/2" TALL	4
28-5	089800	CENTER HANGER, 3 1/4" TALL	2
A2252CB	083400	EQUALIZER BAR, 7 3/4" LONG, CURVED, 9/16" ALL HOLES	2
115052	101800	SHACKLE STRAP, 2 5/8" CENTER OF HOLE	8
9163B	095600	SHACKLE BOLT, 9/16" X 3"	14
916DLN	096800	9/16" HEXLOCKNUT	14

SEE PAGE D-12 & D-13 FOR HANGER LOCATIONS AND OTHER SPECIFICATIONS



## Tandem Axle Hanger Kits for 2,000 - 7,000 lb. Axles (Double Eye Springs)

Part No.	Ref. No.	Description	Qty
APT8	027220	COMPLETE HANGER KIT - INCLUDES THE FOLLOWING:	
115918	089600	FRONT AND REAR HANGER, 2 1/2" TALL	4
E4139	090200	CENTER HANGER, 4 1/4" TALL	2
A2252CB	083400	EQUALIZER BAR, 7 3/4" LONG, CURVED, 9/16" ALL HOLES	2
115052	101800	SHACKLE STRAP, 2 5/8" CENTER OF HOLE	8
9163B	095600	SHACKLE BOLT, 9/16" x 3"	14
916DLN	096800	9/16" HEXLOCKNUT	14

### APT8

For 2,000 - 7,000 lb. axles with double eye springs uses 7 3/4" long curved equalizer, 2 1/2" tall front and rear hanger and a 4 1/4" tall center hanger.

Part No.	Ref. No.	Description	Qty
APT9	027590	COMPLETE HANGER KIT - INCLUDES THE FOLLOWING:	
115918	089600	HANGER, 2 1/2" TALL	6
A2252CB	083400	EQUALIZER BAR, 7 3/4" LONG, CURVED, 9/16" ALL 3 HOLES	2
115052	101800	SHACKLE STRAP, 2 5/8" CENTER OF HOLE	8
9163B	095600	SHACKLE BOLT, 9/16" X 3"	14
916DLN	096800	9/16" HEXLOCKNUT	14

### APT9

For 2,000 - 7,000 lb. axles with double eye springs uses 7 3/4" long curved equalizer, 2 1/2" tall hangers.

Part No.	Ref. No.	Description	Qty
H248	027800	TANDEM AXLE HANGER KIT, USE WITH AP233 - INCLUDES THE FOLLOWING:	
28-5	089800	END HANGER, 3 1/4" TALL	4
29-31	090000	CENTER HANGER, 3 5/8" TALL	2

### H248

Hangers only for 2,000 - 7,000 lb. axles with double eye springs contains 3 5/8" tall center hangers and 3 1/4" tall end hangers. Use with AP233.

Part No.	Ref. No.	Description	Qty
AP233	027600	ATTACHING PARTS KIT, USE WITH KIT H248 - INCLUDES THE FOLLOWING:	
13-104-2	083000	EQUALIZER, CAST, 5 5/8" CURVED	2
9163B	095600	SHACKLE BOLT, 9/16" x 3"	14
916DLN	096800	9/16" HEXLOCKNUT	14
18-11	101600	SHACKLE STRAP, 2 1/4" CENTER OF HOLE	8

### AP233

Attaching Parts Kit only for 2,000 - 7,000 lb. axles with double eye springs uses 5 5/8" curved equalizer and is used with H248 hanger kit above.

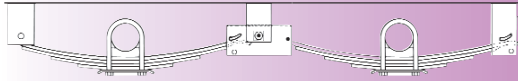

## Tandem Axle Hanger Kits for 3,500 - 8,000 lb. Axles (Slipper Springs)

### APT6SE

For 3,500 - 8,000 lb. axles using 2" slipper springs. Our "heaviest" made Hanger Kit uses 3 3/4" tall front, 3 3/8" center and 5 1/16" tall rear hangers.

Part No.	Ref. No.	Description	Qty
APT6SE	028600	COMPLETE HANGER KIT - INCLUDES THE FOLLOWING:	
721584	091200	FRONT HANGER, 3 3/4" TALL, FOR 2" SLIPPER SPRING	2
721586	091400	CENTER HANGER, 3 3/8" TALL, FOR 2" SLIPPER SPRING	2
721585	091600	REAR HANGER, 5 1/16" TALL, FOR 2" SLIPPER SPRING	2
E5541	084200	EQUALIZER	2
91635B	096400	SHACKLE BOLT, 9/16" x 3 1/2"	8
916DLN	096800	9/16" HEXLOCKNUT	8
7845B	097600	7/8" x 4 11/16" EQUALIZER BOLT	2
78CN	098400	7/8" NUT FOR EQUALIZER BOLT	2
165649	101200	COTTER PIN, 2 1/4" OVERALL	2

### H202

Hangers only for 3,500 - 8,000 lb. axles using 2" slipper springs. Use with AP202 or AP216 (below). Front hanger is 4 1/2" tall, center hanger is 3 1/2" tall and rear hanger is 5 1/4" tall.

Part No.	Ref. No.	Description	Qty
H202	028400	TANDEM AXLE HANGER KIT, USE WITH AP202 OR AP216 - INCLUDES THE FOLLOWING:	
28-1	090600	FRONT HANGER FOR 2" SLIPPER SPRING, 4 1/4" TALL	2
29-1	090800	CENTER HANGER FOR 2" SLIPPER SPRING, 3 1/2" TALL	2
30-28	091000	REAR HANGER FOR 2" SLIPPER SPRING, 5 1/4" TALL	2

### H238

Hangers only for 3,500 - 8,000 lb. axles using 2" slipper springs. Use with AP202 or AP216 (below). Front hanger is 5" tall, center hanger is 4 1/2" tall and rear hanger is 6 3/8" tall.

Part No.	Ref. No.	Description	Qty
H238	028500	TANDEM AXLE HANGER KIT, USE WITH AP202 OR AP216 - INCLUDES THE FOLLOWING:	
28-9-1	091800	FRONT HANGER FOR 2" SLIPPER SPRING, 5" TALL	2
29-5-1	092200	CENTER HANGER FOR 2" SLIPPER SPRING, 4 1/2" TALL	2
30-6-1	092400	REAR HANGER FOR 2" SLIPPER SPRING, 6 3/8" TALL	2

### AP202

Attaching Parts Kit for 3,500 - 8,000 lb. axles with 2" slipper springs uses 7/8" greaseable pivot bolt. Used with H202, or H238 (above), 33" axle spacing when used with 3T3 series springs.

Part No.	Ref. No.	Description	Qty
AP202	028000	ATTACHING PARTS KIT FOR 33" AXLE SPACING, USE WITH KIT H202 -INCLUDES THE FOLLOWING:	
13-4	083800	EQUALIZER	2
7-7	094600	5/16" x 3 1/4" EQUALIZER KEEPER BOLT	4
6-11	094800	5/16" HEX NUT FOR KEEPER BOLT	4
91635B	096400	SHACKLE BOLT, 9/16" x 3 1/2"	4
916DLN	096800	9/16" HEXLOCKNUT	4
7-1-1	098225	7/8" x 4 1/2" WET EQUALIZER BOLT WITH GREASE ZERK	2
6-111	098425	7/8" LOCKNUT FOR EQUALIZER BOLT	2

### AP216

Attaching Parts Kit for 3,500 - 8,000 lb. axles with 2" slipper springs uses 7/8" greaseable pivot bolt. Use with H202, or H238 (above), 36" axle spacing when used with 3T3 series springs.

Part No.	Ref. No.	Description	Qty
AP216	028200	ATTACHING PARTS KIT FOR 36" AXLE SPACING, USE WITH KIT H202 -INCLUDES THE FOLLOWING:	
13-44	084000	EQUALIZER FOR 36" AXLE SPACING	2
7-7	094600	5/16" x 3 1/4" EQUALIZER KEEPER BOLT	4
6-11	094800	5/16" HEX NUT FOR KEEPER BOLT	4
91635B	096400	SHACKLE BOLT, 9/16" x 3 1/2"	4
916DLN	096800	9/16" HEX LOCKNUT	4
7-1-1	098225	7/8" x 4 1/2" WET EQUALIZER BOLT WITH GREASE ZERK	2
6-111	098425	7/8" LOCKNUT FOR EQUALIZER BOLT	2

SEE PAGE D-12 & D-13 FOR HANGER LOCATIONS AND OTHER SPECIFICATIONS

## Combination Kits



Hangers and attaching parts are packaged in the same box for your convenience

Part No.	Ref. No.	Description
AP233-H248	027610	BOXED KIT CONTAINS H248 HANGERS AND AP233 ATTACHING PARTS
AP202-H202	028100	BOXED KIT CONTAINS H202 HANGERS AND AP202 ATTACHING PARTS
AP202-H238	028110	BOXED KIT CONTAINS H238 HANGERS AND AP202 ATTACHING PARTS
AP216-H202	028210	BOXED KIT CONTAINS H202 HANGERS AND AP216 ATTACHING PARTS
AP216-H238	028220	BOXED KIT CONTAINS H238 HANGERS AND AP216 ATTACHING PARTS

SUSPENSIONS

## Triple Axle Hanger Kits for 2,000 - 7,000 lb. Axles (Double Eye Springs)



Part No.	Ref. No.	Description	Qty
APTT1	028800	COMPLETE HANGER KIT- INCLUDES THE FOLLOWING:	
A2251B3	082400	EQUALIZER BAR, 8" LONG, STRAIGHT, (2) 9/16" AND (1)3/4" HOLE	4
115918	089600	END HANGER, 2 1/2" TALL	4
115919	090400	CENTER HANGER, 5 7/16" TALL, 3/4" HOLE	4
9163B	095600	SHACKLE BOLT, 9/16" x 3"	20
916DLN	096800	9/16" HEXLOCKNUT	20
126A1LN	097000	3/4" x 3 1/2" WET EQUALIZER BOLT	4
165093	097400	3/4" NUT FOR EQUALIZER BOLT	4
165649	101200	COTTER PIN, 2 1/4" OVERALL	4
1610	101400	1/4" STRAIGHT GREASE ZERK, WITH 1/8" M.P.T.	4
115052	101800	SHACKLE STRAP, 2 5/8" CENTER OF HOLE	16

### APTT1

For 2,000 - 7,000 lb. axles with double eye springs uses 8" straight equalizer with 3/4" greaseable pivot bolt. End hangers measure 2 1/2" tall and center hangers are 5 7/16" tall.

Part No.	Ref. No.	Description	Qty
APTT3	029000	COMPLETE HANGER KIT - INCLUDES THE FOLLOWING:	
A2252CB	083400	EQUALIZER BAR, 7 3/4" LONG, CURVED, 9/16" ALL 3 HOLES	4
115917	089400	END HANGER, 1 1/2" TALL	4
115918	089600	CENTER HANGER, 2 1/2" TALL	4
9163B	095600	SHACKLE BOLT, 9/16" x 3"	24
916DLN	096800	9/16" HEXLOCKNUT	24
115052	101800	SHACKLE STRAP, 2 5/8" CENTER OF HOLE	16

### APTT3

For 2,000 - 3,500 lb. axles with double eye springs uses 7 3/4" curved equalizer, 1 1/2" tall end hangers and 2 1/2" tall center hangers.

Part No.	Ref. No.	Description	Qty
APTT5	029200	COMPLETE HANGER KIT - INCLUDES THE FOLLOWING:	
A2252CB	083400	EQUALIZER BAR, 7 3/4" LONG, CURVED, 9/16" ALL 3 HOLES	4
28-5	089800	FRONT, CENTER AND END HANGER, 3 1/4" TALL	8
9163B	095600	SHACKLE BOLT, 9/16" x 3"	24
916DLN	096800	9/16" HEXLOCKNUT	24
115052	101800	SHACKLE STRAP, 2 5/8" CENTER OF HOLE	16

### APTT5

For 2,000 - 7,000 lb. axles with double eye springs uses 7 3/4" curved equalizer and 3 1/4" tall hangers in all positions.

SEE PAGE D-12 & D-13 FOR HANGER LOCATIONS AND OTHER SPECIFICATIONS

## Triple Axle Hanger Kit for 3,500 - 8,000 lb. Axles (Slipper Springs)



### H302

Hangers only for 3,500 - 8,000 lb. axles using 2" slipper springs. Use with AP302 or AP316 (below). Front hanger is 4 1/2" tall, center hangers are 3 1/2" tall and rear hanger is 5 1/4" tall.

Part No.	Ref. No.	Description	Qty
H302	029350	TRIPLE AXLE HANGER KIT, USE WITH AP302 OR AP316 - INCLUDES THE FOLLOWING:	
28-1	090600	FRONT HANGER FOR 2" SLIPPER SPRING, 4 1/2" TALL	2
29-1	090800	CENTER HANGER FOR 2" SLIPPER SPRING, 3 1/2" TALL	4
30-28	091000	REAR HANGER FOR 2" SLIPPER SPRING, 5 1/4" TALL	2

### AP302

Attaching Parts kit for 3,500 - 8,000 lb. axles with 2" slipper springs uses 7/8" greaseable pivot bolt. Use with H302 (above), 33" axle spacing when used with 3T3 series springs.

Part No.	Ref. No.	Description	Qty
AP302	029250	ATTACHING PARTS KIT FOR 33" AXLE SPACING, USE WITH KIT H302 -INCLUDES THE FOLLOWING:	
13-4	083800	EQUALIZER	4
7-7	094600	5/16" x 3 1/4" EQUALIZER KEEPER BOLT	6
6-11	094800	5/16" HEX NUT FOR KEEPER BOLT	6
91635B	096400	9/16" x 3 1/2" SHACKLE BOLT	6
916DLN	096800	9/16"HEXLOCKNUT	6
7-1-1	098225	7/8" x 4 1/2" WET EQUALIZER BOLT WITH GREASE ZERK	4
6-111	098425	7/8" LOCKNUT FOR EQUALIZER BOLT	4

### AP316

Attaching Parts kit for 3,500 - 8,000 lb. axles with 2" slipper springs uses 7/8" greaseable pivot bolt. Use with H302 (above), 36" axle spacing when used with 3T3 series springs.

Part No.	Ref. No.	Description	Qty
AP316	029300	ATTACHING PARTS KIT FOR 36" AXLE SPACING, USE WITH KIT H202 -INCLUDES THE FOLLOWING:	
13-44	084000	EQUALIZER FOR 36" AXLE SPACING	4
7-7	094600	5/16" x 3 1/4" EQUALIZER KEEPER BOLT	6
6-11	094800	5/16" HEX NUT FOR KEEPER BOLT	6
91635B	096400	9/16" x 3 1/2" SHACKLE BOLT	6
916DLN	096800	9/16" HEX LOCKNUT FOR SHACKLE BOLT	6
7-1-1	098225	7/8" x 4 1/2" WET EQUALIZER BOLT WITH GREASE ZERK	4
6-111	098425	7/8" LOCKNUT FOR EQUALIZER BOLT	4

### APTT6SE

Our most popular kit fits 3,500 - 8,000 lb. axles with 2" slipper springs. Front hangers are 3 3/4" tall, centers are 3 3/8" tall and the rears measure 5 1/16" tall.

Part No.	Ref. No.	Description	Qty.
APTT6SE	029400	COMPLETE HANGER KIT - INCLUDES THE FOLLOWING:	
E5541	084200	EQUALIZER BAR	4
721584	091200	FRONT HANGER, 3 3/4" TALL, FOR 2" SLIPPER SPRINGS	2
721586	091400	CENTER HANGER, 3 3/8" TALL, FOR 2" SLIPPER SPRINGS	4
721585	091600	REAR HANGER, 5 1/16" TALL, FOR 2" SLIPPER SPRINGS	2
91635B	096400	SHACKLE BOLT, 9/16" x 3 1/2"	12
916DLN	096800	9/16" HEXLOCKNUT	12
7845B	097600	7/8" x 4 11/16" EQUALIZER BOLT	4
78CN	098400	7/8" NUT FOR EQUALIZER BOLT	4
165649	101200	COTTER PIN, 2 1/4" OVERALL	4

SEE PAGE D-12 & D-13 FOR HANGER LOCATIONS AND OTHER SPECIFICATIONS

## Single Axle Hanger & Attaching Parts Kit for 9,000 lb. Axles (Slipper Springs)

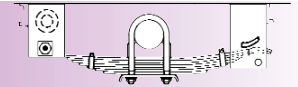

Part No.	Ref. No.	Description	Qty.
HAP-105-00	030420	SINGLE AXLE HANGER AND ATTACHING PARTS KIT -- INCLUDES THE FOLLOWING:	
28-68-4	091780	FRONT HANGER, 5" TALL, 5/8" I.D., FOR 2" WIDE RUBBER BUSHED SLIPPER SPRING	2
30-68-1	092380	REAR HANGER, 6 3/8" TALL, 5/16" I.D., FOR 2" SLIPPER SPRING	2
7-7	094600	SPRING KEEPER BOLT, 5/16" x 3 1/4"	2
6-11	094800	5/16" KEEPER BOLT NUT	2
7-181	096825	SPRING EYE BOLT, 5/8" x 4", FOR 2" RUBBER BUSHED SLIPPER SPRING	2
6-38LN	096850	5/8" SPRING EYE BOLT LOCKNUT	2

### HAP-105-00

For 9,000 lb. axle with 2" wide rubber bushed slipper springs. Also used in conjunction with HAP-205 series kits for 9,000 lb. tandem axle applications (Shown below).

## Multi-Axle Conversion Kits for 9,000 lb. Axles

(Multi-Axle Conversion Kits are designed to be used with the HAP-105-00 Single Axle Kit, shown above.) They are available in 3 different axle spacings, 38", 42 1/4" and 48 1/2". To obtain all parts needed for tandem or triple axle applications, you need 1 Single Axle Kit plus 1 Multi-axle Conversion Kit for each additional axle. For example, for a tandem axle set-up with 48 1/2" axle spacing, you would need 1 each of kits HAP-105-00 and HAP-205-03.



SUSPENSIONS

Part No.	Ref. No.	Description	Qty.
HAP-205-01	030440	9K MULTI-AXLE CONVERSION KIT FOR 38" AXLE SPACING - INCLUDES THE FOLLOWING:	
13-117-03	084220	EQUALIZER, 38" AXLE SPACING	2
29-39-4	092980	CENTER HANGER FOR 4 1/2" TALL, 1" I.D.	2
7-7	094600	SPRING KEEPER BOLT, 5/16" X 3 1/4"	2
6-11	094800	5/16" KEEPER BOLT NUT	2
7-181	096825	SPRING EYE BOLT, 5/8" x 4 1/2", FOR 2" RUBBER BUSHED SPRINGS	2
6-38LN	096850	5/8" SPRING EYE BOLT LOCKNUT	2
7-182	098450	EQUALIZER BOLT, 1"x5"	2
6-112	100600	1" LOCKNUT FOR EQUALIZER BOLT	2

### HAP-205-01

Dexter 9,000 lb. Multi-axle Conversion Kit, 38" axle spacing, use with HAP-105-00.

Part No.	Ref. No.	Description	Qty.
HAP-205-02	030460	9K MULTI-AXLE CONVERSION KIT FOR 42 1/4" AXLE SPACING - INCLUDES THE FOLLOWING:	
13-118-03	084240	EQUALIZER, 42 1/4" AXLE SPACING	2
29-39-4	092980	CENTER HANGER FOR 4 1/2" TALL, 1" I.D.	2
7-7	094600	SPRING KEEPER BOLT, 5/16" x 3 1/4"	2
6-11	094800	5/16" KEEPER BOLT NUT	2
7-181	096825	SPRING KEEPER BOLT, 5/8" x 4"	2
6-38LN	096850	5/8" SPRING EYE BOLT LOCKNUT	2
7-182	098450	EQUALIZER BOLT, 1"x5"	2
6-112	100600	1" LOCKNUT FOR EQUALIZER BOLT	2

### HAP-205-02

Dexter 9,000 lb. Multi-axle Conversion Kit, 42 1/4" axle spacing, use with HAP-105-00.

Part No.	Ref. No.	Description	Qty.
HAP-205-03	030480	9K MULTI-AXLE CONVERSION KIT FOR 48 1/2" AXLE SPACING - INCLUDES THE FOLLOWING:	
13-119-03	084260	EQUALIZER, 48 1/2" AXLE SPACING	2
29-39-4	092980	CENTER HANGER FOR 4 1/2" TALL, 1" I.D.	2
7-7	094600	SPRING KEEPER BOLT, 5/16" x 3 1/4"	2
6-11	094800	5/16" KEEPER BOLT NUT	2
7-181	096825	SPRING KEEPER BOLT, 5/8" x 4"	2
6-38LN	096850	5/8" SPRING EYE BOLT LOCKNUT	2
7-182	098450	EQUALIZER BOLT, 1"x5"	2
6-112	100600	1" LOCKNUT FOR EQUALIZER BOLT	2

### HAP-205-03

Dexter 9,000 lb. Multi-axle Conversion Kit, 48 1/2" axle spacing, use with HAP-105-00.

SEE PAGE D-12 & D-13 FOR HANGER LOCATIONS AND OTHER SPECIFICATIONS

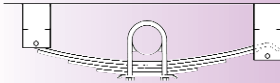

## Single Axle Hanger and Attaching Parts Kits for 10,000 lb. General Duty Axles (Slipper Springs)

### HAP-156-00

Dexter 10,000 lb. General Duty Axles with 2 1/2" wide slipper springs.

Part No.	Ref. No.	Description	Qty.
HAP-156-00	032700	10K GD SINGLE AXLE HANGER AND ATTACHING PARTS KIT INCLUDES THE FOLLOWING:	
28-60	092600	LEFT FRONT HANGER, 5 1/4" TALL, FOR 2 1/2" SLIPPER SPRINGS	1
28-59	092800	RIGHT FRONT HANGER, 5 1/4" TALL, FOR 2 1/2" SLIPPER SPRINGS	1
30-61-1	093200	REAR HANGER, 4 1/2" TALL, FOR 2 1/2" SLIPPER SPRINGS	2
7-135-2	098800	SPRING EYE BOLT, 3/4" X 4 1/2"	2
6-113	100000	3/4" LOCKNUT	2
61-6	101450	1/4" 65 DEGREE ANGLE GREASE ZERK	2

## Multi-Axle Conversion Kits for 10,000 lb. General Duty Axles

Multi-Axle Conversion Kits are designed to be used with the HAP-156-00 Single Axle Kit, above. They are available in 3 different axle spacings, 38", 42 1/4" and 48 1/2". To obtain all parts needed for tandem or triple axle applications, you need 1 single axle kit plus 1 Multi-axle Conversion Kit for each additional axle. For example, for a tandem axle set-up with 48 1/2" axle spacing, you would need 1 each of kits HAP-156-00 and HAP-256-03.



**DEXTER AXLE**

SUSPENSIONS

### HAP-256-01

Dexter 10,000 lb. General Duty Multi-Axle Conversion Kit, 38" axle spacing. Use with HAP-156-00.

Part No.	Ref. No.	Description	Qty.
HAP-256-01	033100	10K QD MULTI-AXLE CONVERSION KIT FOR 38" AXLE SPACING, INCLUDES THE FOLLOWING:	
13-80-1	085000	LEFT HAND EQUALIZER FOR 38" AXLE SPACING	1
13-81-1	085200	RIGHT HAND EQUALIZER FOR 38" AXLE SPACING	1
29-33	093000	CENTER HANGER, 4 1/2" TALL, FOR 2 1/2" SLIPPER SPRINGS	2
7-135-2	098800	SPRING EYE BOLT, 3/4" X 4 1/2"	2
7-136-2	099200	EQUALIZER BOLT, 1" X 5 3/16"	2
6-113	100000	3/4" LOCKNUT FOR SPRING EYE BOLT	2
6-112	100600	1" LOCKNUT FOR EQUALIZER	2
461-6	101450	1/4" 65 DEGREE ANGLE GREASE ZERK, 18" M.P.T.	6

### HAP-256-02

Dexter 10,000 lb. General Duty Multi-Axle Conversion Kit, 42 1/4" axle spacing. Use with HAP-156-00.

Part No.	Ref. No.	Description	Qty.
HAP-256-02	033300	10K GD MULTI-AXLE CONVERSION KIT FOR 42 1/4" AXLE SPACING, INCLUDES THE FOLLOWING:	
13-82-1	085400	LEFT HAND EQUALIZER FOR 42 1/4" AXLE SPACING	1
13-83-1	085600	RIGHT HAND EQUALIZER FOR 42 1/4" AXLE SPACING	1
29-33	093000	CENTER HANGER, 4 1/2" TALL, FOR 2 1/2" SLIPPER SPRINGS	2
7-135-2	098800	SPRING EYE BOLT, 3/4" X 4 1/2"	2
7-136-2	099200	EQUALIZER BOLT, 1" X 5 3/16"	2
6-113	100000	3/4" LOCKNUT FOR SPRING EYE BOLT	2
6-112	100600	1" LOCKNUT FOR EQUALIZER	2
61-6	101450	1/4" 65 DEGREE ANGLE GREASE ZERK, 18" M.P.T.	6

### HAP-256-03

Dexter 10,000 lb. General Duty Multi-Axle Conversion Kit, 48 1/2" axle spacing. Use with HAP-156-00.

Part No.	Ref. No.	Description	Qty.
HAP-256-03	033500	10K GD MULTI-AXLE CONVERSION KIT FOR 48 1/2" AXLE SPACING, INCLUDES THE FOLLOWING:	
13-84-1	085800	LEFT HAND EQUALIZER FOR 48 1/2" AXLE SPACING	1
13-85-1	086000	RIGHT HAND EQUALIZER FOR 48 1/2" AXLE SPACING	1
29-33	093000	CENTER HANGER, 4 1/2" TALL, FOR 2 1/2" SUPPER SPRINGS	2
7-135-2	098800	SPRING EYE BOLT, 3/4" X 4 1/2"	2
7-136-2	099200	EQUALIZER BOLT, 1" X 5 3/16"	2
6-113	100000	3/4" LOCKNUT FOR SPRING EYE BOLT	2
6-112	100600	1" LOCKNUT FOR EQUALIZER	2
61-6	101450	1/4" 65 DEGREE ANGLE GREASE ZERK, 18" M.P.T.	6

SEE PAGE D-12 & D-13 FOR HANGER LOCATIONS AND OTHER SPECIFICATIONS



## Single Axle Hanger Kit for 10,000 - 15,000 lb. Axles (Slipper Springs)

Part No.	Ref. No.	Description	Qty.
HAP-103-00	041620	SINGLE AXLE HANGER AND ATTACHING PARTS KIT - INCLUDES THE FOLLOWING:	
28-67-4	093400	FRONT HANGER, 6 1/4" TALL, 1" I.D., FOR 3" SLIPPER SPRINGS	2
30-66-1	093800	REAR HANGER, 7 11/16" TALL, 1/2" I.D., FOR 3" SLIPPER SPRINGS	2
7-95	098600	SPRING KEEPER BOLT, 1/2" x 4 1/2"	2
7-169	099250	SPRING EYE BOLT, 1" X 5 1/2", FOR 3" RUBBER BUSHED SLIPPER SPRINGS	2
6-112	100600	1" SPRING EYE BOLT LOCKNUT	2
6-46	193000	1/2" KEEPER BOLT LOCKNUT	2

### HAP-103-00

For Dexter 10,000 - 15,000 lb. axles with 3" rubber bushed slipper springs. Also used in conjunction with HAP-203 series for tandem axle applications (Shown below)

## Multi-Axle Conversion Kits for 10,000 lb. - 15,000 lb. Axles

Multi-Axle Conversion Kits are designed to be used with the HAP-103-00 Single Axle Kit. They are available in 3 different axle spacings, 38", 42 1/4" and 48 1/2". To obtain all parts needed for tandem or triple axle applications, you need 1 Single Axle Kit plus 1 Multi-Axle Conversion kit for each additional axle. For example, for a tandem axle set-up with 48 1/2" axle spacing, you would need 1 each of kits HAP-103-00 and HAP-203-03.



SUSPENSIONS

Part No.	Ref. No.	Description	Qty.
HAP-203-01	041640	10-15K MULTI-AXLE CONVERSION KIT, 38" AXLE SPACING - INCLUDES THE FOLLOWING:	
13-107-7LH	086050	LH EQUALIZER FOR 38" AXLE SPACING	1
13-107-8RH	086100	RH EQUALIZER FOR 38" AXLE SPACING	1
29-37-4	093600	CENTER HANGER, 6 1/2" TALL, 1 1/8" I.D., FOR 3" SLIPPER SPRING	2
7-95	098600	SPRING KEEPER BOLT, 1/2" x 4 1/2"	2
7-169	099250	SPRING EYE BOLT, 1" X 5 1/2", FOR 3" WIDE RUBBER BUSHED SLIPPER SPRINGS	2
7-170	099650	EQUALIZER BOLT, 1 1/8" x 6"	2
6-112	100600	1" LOCKNUT FOR SPRING EYE BOLT	2
6-72	101000	1 1/8" LOCKNUT FOR EQUALIZER BOLT	2
6-46	193000	1/2" LOCKNUT FOR KEEPER BOLT	2

### HAP-203-01

Dexter 10,000 - 15,000 lb. Multi-Axle Conversion Kit, 38" axle spacing. Use with HAP-103-00.

Part No.	Ref. No.	Description	Qty.
HAP-203-02	041660	10-15K MULTI-AXLE CONVERSION KIT, 42 1/4" AXLE SPACING - INCLUDES THE FOLLOWING:	
13-108-3LH	086450	LH EQUALIZER FOR 42 1/4" AXLE SPACING	1
13-108-4RH	086500	RH EQUALIZER FOR 42 1/4" AXLE SPACING	1
29-37-4	093600	CENTER HANGER, 6 1/2" TALL, 1 1/8" I.D., FOR 3" SLIPPER SPRING	2
7-95	098600	SPRING KEEPER BOLT, 1/2" x 4 1/2"	2
7-169	099250	SPRING EYE BOLT, 1" X 5 1/2", FOR 3" WIDE RUBBER BUSHED SLIPPER SPRINGS	2
7-170	099650	EQUALIZER BOLT, 1 1/8" x 6"	2
6-112	100600	1" LOCKNUT FOR SPRING EYE BOLT	2
6-72	101000	1 1/8" LOCKNUT FOR EQUALIZER BOLT	2
6-46	193000	1/2" LOCKNUT FOR KEEPER BOLT	2

### HAP-203-02

Dexter 10,000 - 15,000 lb. Multi-Axle Conversion Kit, 42 1/4" axle spacing. Use with HAP-103-00.

Part No.	Ref. No.	Description	Qty.
HAP-203-03	041680	10-15K MULTI-AXLE CONVERSION KITS, 48 1/2" AXLE SPACING - INCLUDES THE FOLLOWING:	
13-109-3LH	086850	LH EQUALIZER FOR 48 1/2" AXLE SPACING	1
13-109-4RH	086900	RH EQUALIZER FOR 48 1/2" AXLE SPACING	1
29-37-4	093600	CENTER HANGER, 6 1/2" TALL, 1 1/8" I.D., FOR 3" SLIPPER SPRING	2
7-95	098600	SPRING KEEPER BOLT, 1/2" x 4 1/2"	2
7-169	099250	SPRING EYE BOLT, 1" X 5 1/2", FOR 3" WIDE RUBBER BUSHED SLIPPER SPRINGS	2
7-170	099650	EQUALIZER BOLT, 1 1/8" x 6"	2
6-112	100600	1" SPRING EYE BOLT LOCKNUT	2
6-72	101000	1 1/8" EQUALIZER BOLT LOCKNUT	2
6-46	193000	1/2" KEEPER BOLT LOCKNUT	2

### HAP-203-03

Dexter 10,000 - 15,000 lb. Multi-Axle Conversion Kit, 48 1/2" axle spacing. Use with HAP-103-00.

SEE PAGE D-12 & D-13 FOR HANGER LOCATIONS AND OTHER SPECIFICATIONS

## Dual Wheel Hanger Locations Chart

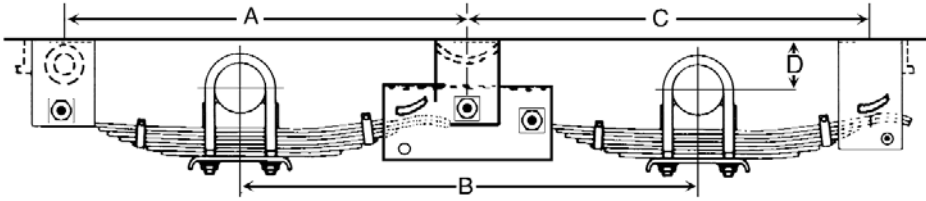

Using this Kit:	Axle Capacity	A	B	C	D*
HAP-105-00 AND HAP-205-01	9K	32 1/2"	38"	33"	4.87
HAP-105-00 AND HAP-205-02	9K	34 1/2"	42 1/4"	35"	4.87
HAP-105-00 AND HAP-205-03	9K	37 1/2"	48 1/2"	38"	4.87
HAP-156-00 AND HAP-256-01	10KGD	33"	38"	32 1/2"	4.99
HAP-156-00 AND HAP-256-02	10KGD	35"	42 1/4"	34 1/2"	4.99
HAP-156-00 AND HAP-256-03	10KGD	38 1/4"	48 1/2"	37 5/8"	4.99
HAP-103-00 AND HAP-203-01	10K-15K	33"	38"	32 1/2"	5.49
HAP-103-00 AND HAP-203-02	10K-15K	35"	42 1/4"	34 1/2"	5.49
HAP-103-00 AND HAP-203-03	10K-15K	38 1/2"	48 1/2"	37 1/2"	5.49

\* Ride height dimensions are at rated load capacity of suspension

## 9,000 – 15,000 lb. Axle Spring Hanger Recommended Reinforcements

CROSS FRAME REINFORCEMENT BETWEEN SPRING AND EQUALIZER HANGER BRACKETS ASSURES FULL LOAD CARRYING CAPABILITY OF THE AXLE MOUNTED STRUCTURE.

STANDARD THREE INCH STRUCTURAL CHANNEL IS SUGGESTED FOR REINFORCEMENT MEMBERS.

WELDS SHALL BE AS INDICATED.

### RECOMMENDED HANGER WELDING PROCEDURE

WELD AROUND CORNER AS SHOWN

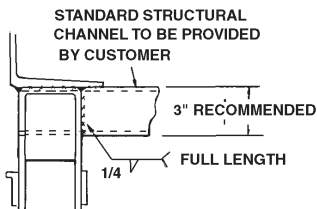
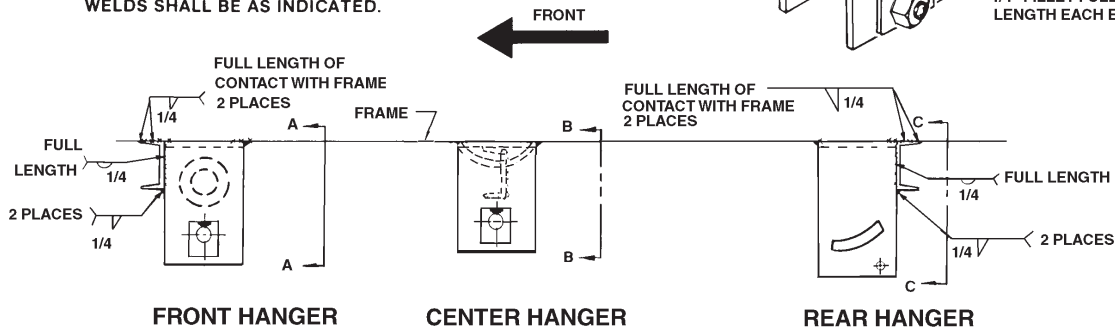
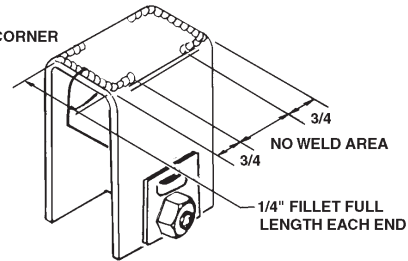

VIEW AA

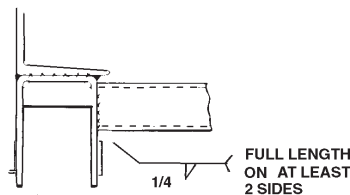

VIEW BB

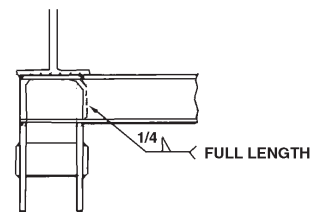

VIEW CC

## Hanger Locations Chart

Using this Hanger Kit:	With This Spring Set(s):	A	B*	Axle Diameter
APS3SE	WIC2, WIE3	23"	3 3/4"	1 3/4"
APS3SE	WID2, WIF3, WIG4	28"	4"	1 3/4"
APS1	1020	20"	4 1/2"	1 3/4"
APS1	PR722,3, 4, 4B,5,6	25 3/4"	4 1/4"	2 3/8"
APS3	1020	20"	4 1/2"	1 3/4"
APS3	PR722, 3, 4, 4B,5,6	25 3/4"	4"	2 3/8"
APS4	1020	20"	5 1/2"	1 3/4"
APS4	PR722, 3, 4, 4B, 5, 6	25 3/4"	5"	2 3/8"
APS5	1020	20"	5 3/8"	1 3/4"
APS5	PR722,3, 4, 4B,5,6	25 3/4"	4 3/4"	2 3/8"
APS6SE	803T3,1203T3, 1403T3	26"	4 3/4"	3"
APS6SE	E5226	26"	5"	3"
APS6SE	E5115	28"	5"	3"

### Single Axles

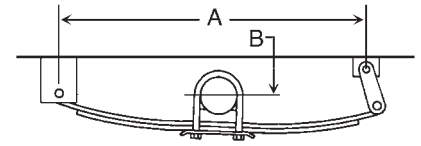

Using this Hanger Kit:	With This Spring Set(s):	A	B	C	D*	Axle Diameter
APT1	1020	24 3/4"	24 3/4"	29 1/2"	4 1/2"	1 3/4"
APT1	PR722,3, 4, 4B,5,6	29 1/2"	29 1/2"	34"	4"	2 3/8"
APT3	1020	24 3/4"	24 3/4"	30"	3 3/4"	1 3/4"
APT3	PR722,3, 4, 4B,5,6	29 1/2"	29 1/2"	33 1/2"	3 1/2"	2 3/8"
APT5	1020	24 3/4"	24 3/4"	29 1/2"	5"	1 3/4"
APT5	PR722,3, 4, 4B,5,6	29 1/2"	29 1/2"	33 1/2"	4 1/2"	3"
AP233/H248	1020	25"	25"	29"	5"	1 3/4"
AP233/H248	PR722, 3, 4, 4B, 5, 6	29 1/2"	29 1/2"	34"	4 1/2"	2 3/8"
APT6SE	E5226	29 3/4"	29 3/4"	34 1/2"	4 3/4"	3"
APT6SE	803T3,1203T3, 1403T3	28 1/2"	29 1/2"	33"	4 1/2"	3"
APT6SE	E5115	32"	32"	36 3/4"	4 3/4"	3"
AP202/H202	803T3,1203T3,1403T3	28 3/4"	28 3/4"	33 1/2"	5 1/4"	3"
AP202/H202	E5226	29 3/4"	29 3/4"	34 1/2"	5"	3"
AP202/H202	E5115	32 1/2"	32 1/2"	36 3/4"	4 3/4"	3"
AP216/H202	803T3,1203T3, 1403T3	30 1/2"	30 1/2"	36"	5"	3"
AP216/H202	E5226	31 1/2"	31 1/2"	37"	5"	3"
AP216/H202	E5115	33 3/4"	33 3/4"	39"	5"	3"

### Tandem Axles

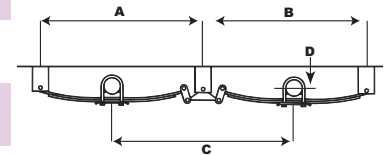

### Triple Axle

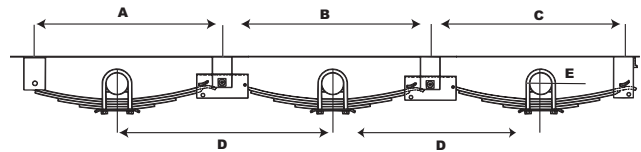

Using this Hanger Kit:	With This Spring Set(s):	A	B	C	D	E*	AXLE DIAMETER
APTT1	1020	24 3/4"	29"	24 3/4"	28 1/2"	4 1/2"	1 3/4"
APTT1	PR722,3,4, 4B,5,6	29 1/2"	34"	29 1/2"	34"	4"	2 3/8"
APTT3	1020	24 3/4"	29"	24 3/4"	28 1/2"	4 1/2"	1 3/4"
APTT3	PR722,3, 4, 4B,5,6	29 1/2"	34"	29 1/2"	34"	3 1/2"	2 3/8"
APTT5	1020	24 3/4"	29"	24 3/4"	28 1/2"	4 1/2"	1 3/4"
APTT5	PR722, 3, 4, 4B, 5, 6	29 1/2"	34"	29 1/2"	34"	5"	2 3/8"
APTT6SE	803T3,1203T3,1403T3	29"	33 1/2"	29"	33 1/2"	4 3/4"	3"
APTT6SE	E5226	29 1/2"	34"	29 1/2"	34"	4 3/4"	3"
APTT6SE	E5115	32"	36 1/2"	32"	36 3/4"	4 3/4"	3"

\*All dimensions shown should be considered as "zero load" on suspensions, without weight of trailer or cargo. Allow 1.5" deflection at rated capacity of spring for approximate full load dimension and 3" above tires beyond that point for "maximum bump clearance." For best suspension performance, allow 2-2.5" clearance above top of axle to bottom of frame. Use of "bump stops" are recommended above 2.5" clearance.

## Double Eye Springs

When replacing worn or broken springs, be sure to measure old springs as noted in the diagram. Your worn spring will be longer than a new spring due to wear. Be sure to call and let our professionals help you select the proper replacement.

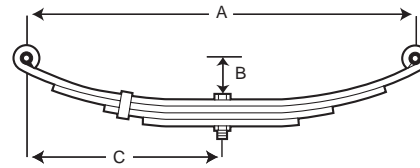

Part No.	Ref. No.	No. of Leaves	Capacity	A	B	C	Width	Eye Diameter
1020	065000	3	1000 lbs.	20 1/4"	3 3/16"	10 3/16"	1 3/4"	9/16"
1724	065200	3	1750 lbs.	23 1/4"	3 1/2"	11 1/2"	1 3/4"	9/16"
PR722	065420	3	1250 lbs.	25 1/4"	3"	12 5/8"	1 3/4"	9/16"
PR3	065600	3	1750 lbs.	25 1/4"	3"	12 5/8"	1 3/4"	9/16"
PR4B	065800	4	1750 lbs.	25 1/4"	3"	12 5/8"	1 3/4"	9/16"
PR4	066000	4	2400 lbs.	25 1/4"	3"	12 5/8"	1 3/4"	9/16"
PR5	066200	5	2900 lbs.	25 1/4"	3"	12 5/8"	1 3/4"	9/16"
PR6	066400	6	3300 lbs.	25 1/4"	3"	12 5/8"	1 3/4"	9/16"
TE30	066600	1	3000 lbs.	25 1/4"	3"	12 5/8"	1 3/4"	9/16"
PR427	066800	4	1800 lbs.	27"	2 3/4"	13 1/2"	1 3/4"	9/16"
PR626	067000	6	2250 lbs.	26"	3 3/4"	13"	1 3/4"	9/16"

## Slipper Springs

Slipper Springs should be measured at points A, B, C & D, to best determine the proper spring for replacement.

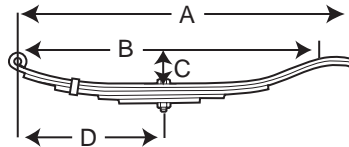

Part No.	Ref. No.	No. of Leaves	Capacity in lbs.	A	B	C	D	Width	Eye Diameter
WIC2	067200	2	500	24 1/4"	23 1/8"	4"	11"	1 3/4"	9/16"
WIE3	067400	3	750	24 1/4"	23 1/8"	4"	11"	1 3/4"	9/16"
WIH4	067600	4	1000	24 1/4"	23 1/8"	4"	11"	1 3/4"	9/16"
WID2	067800	2	1000	30 1/4"	27 3/8"	4 1/2"	13 1/2"	1 3/4"	9/16"
WIF3	068000	3	1500	30 1/4"	27 3/8"	4 1/2"	13 1/2"	1 3/4"	9/16"
WIG4	068200	4	1750	30 1/4"	27 3/8"	4 1/2"	13 1/2"	1 3/4"	9/16"
803T3	068400	4	2000	26 1/8"	24 7/8"	3"	11 3/16"	2"	9/16"
1003T3	068600	4	2500	26 1/8"	24 7/8"	3"	11 3/16"	2"	9/16"
E5226	068800	5	3000	26 5/8"	25 1/4"	3 1/2"	12"	2"	9/16"
1203T3	069000	5	3500	26 1/8"	24 7/8"	3"	11 3/16"	2"	9/16"
1403T3	069200	7	4000	26 1/8"	24 7/8"	3"	11 3/16"	2"	9/16"
E5115	069400	6	4000	29 1/2"	27 1/2"	3 1/2"	13 1/2"	2"	9/16"
72-10-2	069550	6	4500	30"	26 7/8"	3 7/8"	13 1/8"	2"	5/8"
E8536	069800	8	5000	29 1/2"	27 1/2"	3 1/2"	13 1/2"	2"	9/16"
093161	070000	5	5000	32 1/2"	29"	4"	14"	2 1/2"	3/4"
72-21	070200	5	5000	30"	26 7/8"	4"	13 1/2"	2 1/2"	3/4"
72-43-1	070250	5	5000	30"	26 3/4"	4"	13 3/8"	3"	1"
72-44-1	070450	6	6000	30"	26 3/4"	4"	13 3/8"	3"	1"
72-45-1	070650	7	7500	30"	26 3/4"	4"	13 3/8"	3"	1"
72-48	071000	3	11,200	43 3/4"	42"	6 1/4"	N/A	3"	N/A

NOTE: Dimensions shown above are for identification purposes only. Slight dimension variances should be allowed for due to spring manufacturing tolerances. "Replacement in pairs" is recommended for proper axle alignment and suspension performance.



## Suspension Bushings



The table below contains the Replacement Bushings used in equalizers and springs of various types and styles.

Part No.	Ref. No.	I.D.	O.D.	Length	Description
ENP322	103775	1/2"	7/8"	1 3/4"	NYLON, SPRING EYE
ENP605	103785	9/16"	7/8"	1 3/4"	NYLON, SPRING EYE
155228	104000	1/2"	11/16"	1 3/4"	NYLON, SPRING EYE, "WI" SERIES
722106	104200	9/16"	11/16"	1 3/4"	NYLON, SPRING EYE / EQUALIZER
722107	104400	9/16"	11/16"	2"	NYLON, SPRING EYE
722108	104410	9/16"	3/4"	1 3/4"	NYLON, EQUALIZER
722109	104420	3/4"	7/8"	1 3/4"	NYLON, EQUALIZER
722109A	104425	3/4"	.91"	1 3/4"	NYLON, EQUALIZER
721590	104430	7/8"	1 1/16"	2 15/16"	NYLON, EQUALIZER
091414	104450	1"	2 1/8"	4"	RUBBER/STEEL SLEEVED, EQUALIZER, HAYES 10K
14-54	104600	9/16"	1 5/16"	2"	NYLON, SPRING EYE (2-PIECE)
14-73	104650	5/8"	1 3/8"	2 3/16"	RUBBER/STEEL SLEEVED, SPRING EYE, DX 9K
14-67	104675	3/4"	1"	2 1/2"	BRONZE, SPRING EYE, DX 10K GD
14-69	104700	1"	2"	3"	RUBBER/STEEL SLEEVED, SPRING EYE, DX 10K - 15K
14-51	104800	1"	1 1/4"	3"	BRONZE, SPRING EYE, OLD STYLE DX 10K - 15K
091413	105000	3/4"	1 3/4"	2 3/4"	RUBBER/STEEL SLEEVED, SPRING EYE, HAYES 10K

## Spring Center Tie Bolts

Part No.	Ref. No.	Description
516-3TB	103200	5/16" x 3" SPRING CENTER TIE BOLT WITH NUT
516-TBN	103230	5/16" NUT FOR SPRING CENTER TIE BOLT
38-3TB	103400	3/8" X 3" SPRING CENTER TIE BOLT WITH NUT
38-5TB	103600	3/8" X 5" SPRING CENTER TIE BOLT WITH NUT
38N	077600	3/8" NUT FOR SPRING CENTER TIE BOLT



We carry the most popular replacement center tie bolts used in the industry.

## U-Bolt Kits

Part No.	Ref. No.	Description	Quantity
APUBR-10	071200	U-BOLT KIT - INCLUDES THE FOLLOWING:	
175643LN	072400	U-BOLT, 1 3/4" ROUND, 3/8" DIAMETER, 4 1/4" LONG	4
38N	077600	NUTS, 3/8" I.D.	8
117537	079400	AXLE PLATE	2

**1 3/4" Round Axle,  
1 3/4" Wide Spring**  
Commonly used on 2,000 lb. straight axles.

Part No.	Ref. No.	Description	Quantity
APUBR-1	071400	U-BOLT KIT - INCLUDES THE FOLLOWING:	
176400LN	073200	U-BOLT, 2 3/8" ROUND, 1/2" DIAMETER, 5 1/2" LONG	4
12N	078000	NUTS, 1/2" I.D.	8
117595	079600	AXLE PLATE	2

**2 3/8" Round Axle,  
1 3/4" Wide Spring**  
Commonly used on 2,000 lb. drop axles and 3,500 lb. axles with 2 3/8" tube O.D.

Part No.	Ref. No.	Description	Quantity
APUBR-8	071600	U-BOLT KIT - INCLUDES THE FOLLOWING:	
1755892LN	073600	U-BOLT, 3" ROUND, 1/2" DIAMETER, 7" LONG	4
12N	078000	NUTS, 1/2" I.D.	8
117521	080200	AXLE PLATE	2

**3" Round Axle,  
1 3/4" or 2" Wide Spring**  
Commonly used on 5,200 lb., 6,000 lb., 7,000 lb. and 3,500 lb axles with 3" tube O.D.

## U-Bolt Kits

### 3" Round Axle,

### 1 3/4" or 2" Wide Spring

Used as a "heavier duty" U-bolt kit on 5,200 lb., 6,000 lb. and 7,000 lb. axles because of the U-bolt diameter of 9/16".

Part No.	Ref. No.	Description	Quantity
APUBR-9	071800	U-BOLT KIT - INCLUDES THE FOLLOWING:	
176500LN	074000	U-BOLT, 3" ROUND, 9/16" DIAMETER, 7 1/4" LONG	4
916N	078400	NUTS, 9/16" I.D.	8
117521	080200	AXLE PLATE	2

### 3 1/2" Round Axle, 2" Wide Spring

Used on 8,000 lb. axles with 3 1/2" diameter tube.

Part No.	Ref. No.	Description	Quantity
APUBR-35	072000	U-BOLT KIT - INCLUDES THE FOLLOWING:	
11-65LN	074400	U-BOLT, 3 1/2" ROUND, 9/16" DIAMETER, 8" LONG	4
916N	078400	NUTS, 9/16" I.D.	8
117581	080400	AXLE PLATE	2

## Replacement U-Bolts - Round End

- Replacement for 2,000 lb. - 15,000 lb. Axles

Part No.	Ref. No.	(A) Size	Description	(D) Diameter	(L) Length
175643	072200	1 3/4"	WITH NUTS FOR 2K AXLES	3/8"	4 1/4"
175668	072600	2 1/2"	WITH NUTS FOR 7.5K SOLID BAR AXLES	9/16"	7 3/4"
176400	073000	2 3/8"	WITH NUTS FOR 3.5K AXLES	1/2"	5 1/2"
1755892	073400	3"	WITH NUTS FOR 5.2K, 6K AND 7K AXLES	1/2"	7"
176500	073800	3"	WITH NUTS FOR 5.2K, 6K AND 7K AXLES	9/16"	7 1/4"
11-65	074200	3 1/2"	WITH NUTS FOR 8K AXLES	9/16"	8"
175666	074500	3 1/2"	WITH NUTS FOR 8K AXLES W/10 LEAF SPRING	9/16"	9"
11-64	074800	4"	WITH LOCKNUTS FOR 9K AXLES	5/8"	8 1/8"
11-77	075200	5"	WITH LOCKNUTS FOR 10K AXLES	5/8"	8 7/8"
091148	075600	5"	WITH NUTS FOR HAYES 10K AXLES	5/8"	9 1/2"
11-70	076000	5"	WITH LOCKNUTS FOR 12K AND 15K AXLES	3/4"	9 5/8"

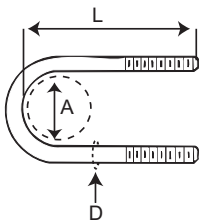

## Replacement U-Bolts - Square End

- For 1 1/2" to 2" Square Tubing

Part No.	Ref. No.	(A) Size	(D) Diameter	(L) Length
1753223	076400	1 1/2"	1/2"	5"
175130	076800	1 3/4"	9/16"	5"
175211	077200	2"	9/16"	5 3/4"

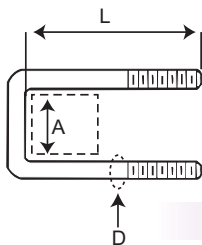

See Page D-22 for Redline Packaged U-Bolts

## U-Bolt Nuts

Part No.	Ref. No.	Description
38N	077600	3/8"-24 U-BOLT NUT
12N	078000	1/2"-20 U-BOLT NUT
916N	078400	9/16"-18 U-BOLT NUT
6-38	078800	5/8"-11 U-BOLT LOCKNUT
6-113	100000	3/4"-10 U-BOLT LOCKNUT

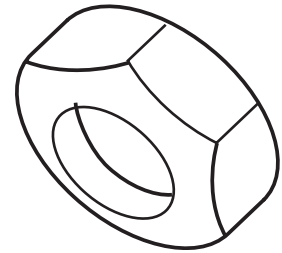

## U-Bolt Axle Plates

Part No.	Ref. No.	Axle Size	Spring Width	U-Bolt Size	Axle Type
117537	079400	1 3/4" RD	1 3/4"	3/8"	2K STRAIGHT
117595	079600	2 3/8" RD	1 3/4"	1/2"	3.5K, 2K DROP
12-4	079800	2 3/8" RD	2"	1/2"	3.5K, 2K DROP
117858	080000	2 1/2" RD	2"	9/16"	7.5K SOLID BAR
117521	080200	3" RD	1 3/4" or 2"	1/2" or 9/16"	6K - 7K, 3.5K HD
117581	080400	3 1/2" RD	1 3/4" or 2"	9/16"	DX 8K
12-42	080600	4" RD	2"	5/8"	DX 9K
12-49	080800	5" RD	2 1/2"	5/8"	DX 10K GD & HAYES 10K
12-53	081200	5" RD	3"	5/8"	DX 10K HD
12-46	081400	5" RD	3"	3/4"	DX 12K - 15K
115983	081600	1 1/2" SQ	1 3/4"	1/2"	SQUARE BAR
116308	081800	1 3/4" SQ	1 3/4"	9/16"	SQUARE BAR
117594	082000	2" SQ	1 3/4" or 2"	9/16"	SQUARE BAR

Replacements for all axles with 1 3/4" to 5" diameter tube.

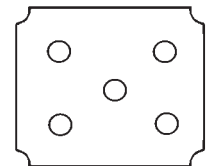

## Shackle Straps

Part No.	Ref. No.	Width	Size
18-11	101600	1 1/4"	2 1/4" CENTER OF HOLE TO CENTER OF HOLE
115052	101800	1 1/4"	2 5/8" CENTER OF HOLE TO CENTER OF HOLE
115208	102000	1 1/4"	3 1/8" CENTER OF HOLE TO CENTER OF HOLE

Shackle Straps are a popular replacement item for double eye suspensions. Available in 3 lengths. (9/16" hole)



See Page D-22 for Redline Packaged Shackle Straps

## Hanger for "WI" Series Springs

Used on 1 3/4" wide "WI" series slipper springs with 9/16" spring eye I.D.

Part No.	Ref. No.	Description	Top to Center of Hole	Bolt Size
115706S	088800	REAR HANGER	N/A	N/A
115917	089400	FRONT HANGER, 9/16" EYE	1 1/2"	9/16"

## Hangers for Double Eye Springs

Used on 1 3/4" wide springs with 9/16" spring eye I.D.

Part No.	Ref. No.	Description	Top to Center of Hole	Bolt Size
93003-3X	089150	REAR HANGER, NO BUSHING, SINGLE AXLE ONLY	1 1/2"	9/16"
30-20	089200	REAR HANGER, SINGLE AXLE ONLY	.91"	9/16"
115917	089400	FRONT OR REAR HANGER	1 1/2"	9/16"
115918	089600	CENTER HANGER	2 1/2"	9/16"
28-5	089800	FRONT, CENTER OR REAR HANGER	3 1/4"	9/16"
29-31	090000	HANGER	3 5/8"	9/16"
E4139	090200	HANGER	4 1/4"	9/16"
115919	090400	CENTER HANGER	5 7/16"	3/4"

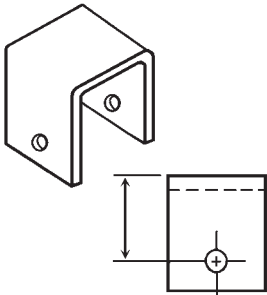

SUSPENSIONS

## Hangers for 2" Slipper Springs

Front, Center and Rear Hangers for all applications of 2" wide slipper springs on 3,500 - 9,000 lb. axles.

Part No.	Ref. No.	Description	Top to Center of Hole	Bolt Size
28-1	090600	FRONT HANGER OF H202	4 1/4"	9/16"
29-1	090800	CENTER HANGER OF H202	3 1/2"	7/8"
30-28	091000	REAR HANGER OF H202	5 1/4"	5/16"
721584	091200	FRONT HANGER OF APT6SE	3 3/4"	9/16"
721586	091400	CENTER HANGER FOR APT6SE	3 3/8"	7/8"
721585	091600	REAR HANGER FOR APT6SE	5 1/16"	9/16"
28-68-4	091780	FRONT HANGER OF HAP-105	5"	5/8"
28-9-1	091800	FRONT HANGER	5"	9/16"
29-5-1	092200	CENTER HANGER	4 1/2"	7/8"
30-68-1	092380	REAR HANGER FOR HAP-105	6 1/4"	5/16"
30-6-1	092400	REAR HANGER	6 3/8"	5/16"
29-39-4	092980	CENTER HANGER FOR HAP-205	4 1/2"	1"

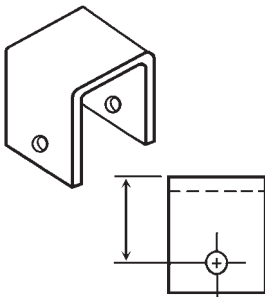

## Hangers for 2 1/2" Slipper Springs

Front, Center and Rear Hanger Replacements of Dexter 10,000 lb. General Duty and Hayes 9K, 10K, 12K axles.

Part No.	Ref. No.	Description	Top to Center of Hole	Bolt Size
28-60	092600	LEFT FRONT HANGER FOR H258	5 1/4"	3/4"
28-59	092800	RIGHT FRONT HANGER FOR H258	5 1/4"	3/4"
29-33	093000	CENTER HANGER FOR H258	5 3/8"	3/4"
30-61-1	093200	REAR HANGER FOR H258	4 1/2"	NA
092829	094000	FRONT HANGER FOR HAYES	5 1/4"	3/4"
092920	094200	CENTER HANGER FOR HAYES	1 7/8"	1"
093026	094400	REAR HANGER FOR HAYES	6"	NA

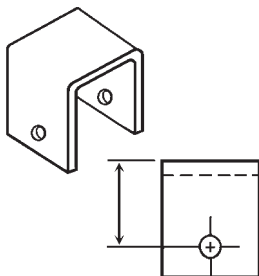



## Hangers for 3" Slipper Springs

Part No.	Ref. No.	Description	Top to Center of Hole	Bolt Size
28-67-4	093400	FRONT HANGER FOR HAP-103	6 1/4"	1"
29-37-4	093600	CENTER HANGER FOR HAP-203	4 1/2"	1 1/8"
30-66-1	093800	REAR HANGER FOR HAP-103	7 11/16"	1/2"

Used on Dexter 10,000 - 15,000 lb. axles.

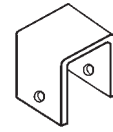

## Straight Equalizers

Part No.	Ref. No.	A	B	C	D	O.D.
A2251B	082200	8"	4"	9/16"	9/16"	1 3/4"
A2251B3	082400	8"	4"	9/16"	3/4"	1 3/4"

For double eye springs, the A2251B3 is used in the APT1, APTT1 hanger kits.

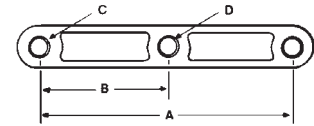

SUSPENSIONS

## Tall Triangular Equalizer

Widely used for years in the R.V. and Mobile Home industry.

Part No.	Ref. No.	A	B	C	O.D.
13-10	082600	6"	4"	9/16"	1 3/4"

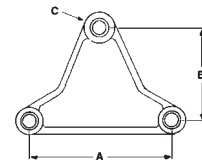

## Curved Equalizers

The 13-104-2 Equalizer is found in AP233 Attaching Parts Kit. A2252CB is found in the APT3, APT5, APTT3 and APTT5 Attaching Parts Kits.

Part No.	Ref. No.	A	B	C	D	E	O.D.
13-104-2	083000	5 5/8"	2 13/16"	9/16"	9/16"	2"	1 3/4"
A2252CB	083400	7 3/4"	3 7/8"	9/16"	9/16"	2 7/8"	1 3/4"
A2252CB34	083600	7 3/4"	3 7/8"	3/4"	9/16"	2 7/8"	1 3/4"

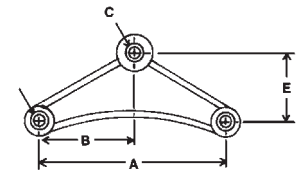

## Short Curved Equalizer

The 220AIT3B is found in APT4, APTT4 hanger kits.

Part No.	Ref. No.	A	B	C	D	E	O.D.
220AIT3B	083200	6 1/4"	3 1/8"	3/4"	9/16"	2"	1 3/4"

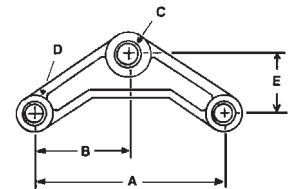

## Equalizer for 2" Slipper Springs

Used by Dexter Axle for years, this Equalizer is found in the AP202 attaching parts kit.

Part No.	Ref. No.	A	B	C	D	E	F	I.D.
13-4	083800	4 5/8"	5 1/2"	5"	9/16"	5/16"	7/8"	2 1/4"

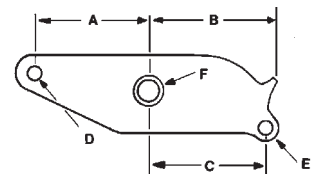

## Equalizers for 2" Slipper Springs

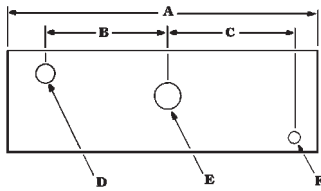

- 13-44 is found in AP216 attaching parts kit
- E5541 is found in APT6SE hanger kit
- 13-117, 118, and 119 are for new style Dexter 8-9K

Part No.	Ref. No.	A	B	C	D	E	F	I.D.
13-44	084000	13 1/8"	5 1/2"	6"	9/16"	15/16"	3/8"	2 3/16"
E5541	084200	12"	4 3/4"	4 5/8"	9/16"	7/8"	9/16"	2 3/16"
13-117-03	084220	13 1/8"	5 1/2"	5 9/16"	5/8"	15/16"	5/16"	2 3/16"
13-118-03	084240	17 3/8"	7 5/8"	7 3/4"	5/8"	15/16"	5/16"	2 3/16"
13-119-03	084260	23 1/2"	10 3/4"	10 3/4"	5/8"	15/16"	5/16"	2 3/16"

## Equalizers for 2 1/2" Slipper Springs

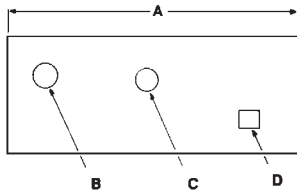

- Used on Dexter 10,000 lb. General Duty axles
- Found in HAP-256 Series Hanger Kits
- Part numbers 13-80, -82, -84 are left hand equalizers
- Part numbers 13-81, -83, -85 are right hand equalizers

Part No.	Ref. No.	A	B	C	D	I.D.
13-80-1	085000	14 1/4"	1 3/8"	1"	3/4"	2 3/4"
13-81-1	085200	14 1/4"	1 3/8"	1"	3/4"	2 3/4"
13-82-1	085400	18 3/8"	1 3/8"	1"	3/4"	2 3/4"
13-83-1	085600	18 3/8"	1 3/8"	1"	3/4"	2 3/4"
13-84-1	085800	24 5/8"	1 3/8"	1"	3/4"	2 3/4"
13-85-1	086000	24 5/8"	1 3/8"	1"	3/4"	2 3/4"



## Equalizers for 3" Slipper Springs

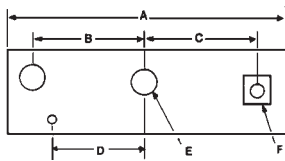

Part No.	Ref. No.	Axle Spacing	A	C	D	E	F	I.D.
13-107-7LH	086050	38"	14 1/4"	5"	4 1/2"	1 1/8"	1"	3 1/8"
13-107-8RH	086100	38"	14 1/4"	5"	4 1/2"	1 1/8"	1"	3 1/8"
13-108-3LH	086450	42 1/4"	18 3/8"	7 1/8"	6 3/4"	1 1/8"	1"	3 1/8"
13-108-4RH	086500	42 1/4"	18 3/8"	7 1/8"	6 3/4"	1 1/8"	1"	3 1/8"
13-109-3LH	086850	48 1/2"	24 3/4"	10 3/8"	10"	1 1/8"	1"	3 1/8"
13-109-4RH	086900	48 1/2"	24 3/4"	10 3/8"	10"	1 1/8"	1"	3 1/8"



## Equalizers for Hayes 2 1/2" Slipper Springs

- 1995 Hayes changed from Universal to LH and RH specific.
- Equalizer is stamped L or R to identify. Tab lock/reinforcement plate goes to the outside of trailer.

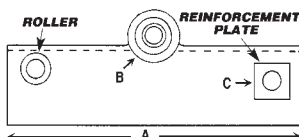

Part No.	Ref. No.	LH / RH	A	B	C	I.D.
09138706	087400	LH	11 1/2"	1"	3/4"	2 3/4"
09138707	087405	RH	11 1/2"	1"	3/4"	2 3/4"
09138708	087600	LH	15 3/4"	1"	3/4"	2 3/4"
09138709	087605	RH	15 3/4"	1"	3/4"	2 3/4"
09138710	087800	LH	21 3/4"	1"	3/4"	2 3/4"
09138711	087805	RH	21 3/4"	1"	3/4"	2 3/4"

## Cotter Pins and Grease Zerks



Part No.	Ref. No.	Size	Description
165649	101200	1/8" x 1 3/4"	COTTER PIN
1610	101400	3/8"	1/4" STRAIGHT GREASE ZERK, 1/8" M.P.T.
61-6	101450	3/8"	1/4" 65 DEGREE ANGLE GREASE ZERK, 1/8" M.P.T.

## Popular Suspension Bolts with Nuts

Part No.	Ref. No.	Diameter	Length	Description
166081	095800	9/16"	3"	SHACKLE BOLT W/NUT FOR DOUBLE EYE SPRINGS
126B2	096200	9/16"	3"	WET SHACKLE BOLT W/NUT & ZERK FOR DOUBLE EYE SPRINGS
166079	096600	9/16"	3 1/2"	SPRING EYE BOLT W/NUT FOR SLIPPER SPRINGS
126A1	097200	3/4"	3 1/2"	WET EQUALIZER BOLT W/NUT, ZERK & COTTER PIN
166078	097800	7/8"	4 11/16"	EQUALIZER BOLT W/NUT, COTTER PIN
166074	098250	7/8"	4 11/16"	WET EQUALIZER BOLT W/LOCKNUT, ZERK PRESSED IN

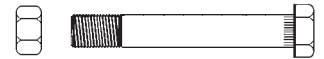
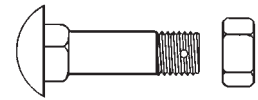

## Suspension Bolts

Part No.	Ref. No.	Size	Length	Description	Grade
7-7	094600	5/16"-18	3 1/4"	SPRING RETAINER BOLT	2
7-95	098600	1/2"-20	4 1/2"	10K, 12K, 15K SPRING RETAINER BOLT	2
9163B	095600	9/16"-18	3"	DOUBLE EYE SHACKLE BOLT	5
126B2LN	096000	9/16"-18	3"	GREASE TYPE DOUBLE EYE SHACKLE BOLT	5
91635B	096400	9/16"-18	3 1/2"	SLIPPER SPRING SHACKLE BOLT	5
7-181	096825	5/8"-11	4"	9K SPRING EYE BOLT (NEW STYLE)	5
126A1LN	097000	3/4"-16	3 1/2"	GREASE TYPE EQUALIZER CENTER BOLT	5
7-135-2	098800	3/4"-10	4 1/2"	10K GENERAL DUTY SPRING EYE BOLT	5
090747	099000	3/4"-16	4 1/2"	10K, 12K HAYES SPRING EYE BOLT	5
7845B	097600	7/8"-9	4 11/16"	EQUALIZER CENTER BOLT	2
7-1-1	098225	7/8"-9	4 5/8"	GREASE TYPE EQUALIZER CENTER BOLT	2
7-182	098450	1"-8	5"	9K (NEW STYLE) EQUALIZER CENTER BOLT	5
7-169	099250	1"-8	5 1/2"	10K, 12K, 15K DEXTER SPRING EYE BOLT	5
7-136-2	099200	1"-8	5 7/8"	10K GENERAL DUTY EQUALIZER CENTER BOLT	5
090746	099600	1"-14	5 7/8"	10K, 12K HAYES EQUALIZER CENTER BOLT	5
7-170	099650	1 1/8"-7	6"	10K, 12K, 15K DEXTER EQUALIZER CENTER BOLT	5

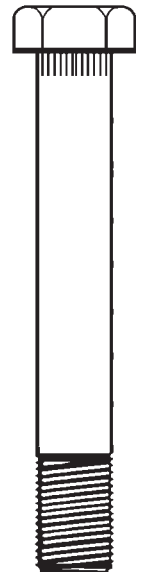

SUSPENSIONS

## Suspension Nuts

Part No.	Ref. No.	Size	Description
6-11	094800	5/16"-18	HEX NUT FOR 7-7 KEEPER BOLT
38N	077600	3/8"-24	U-BOLT NUT FOR 175643LN U-BOLTS
12N	078000	1/2"-20	U-BOLT NUT FOR 176400LN, 1755892LN
916DLN	096800	9/16"-18	HEX LOCKNUT FOR 91638, 91635B SHACKLE BOLTS
916N	078400	9/16"-18	U-BOLT NUT FOR 176500LN, 11-65N U-BOLTS
6-38LN	096850	5/8"-11	LOCKNUT FOR 7-181, 9K SPRING EYE BOLT
6-38	078800	5/8"-11	U-BOLT LOCKNUT FOR 11-64LN AND 11-77LN
165093	097400	3/4"-16	CASTLE NUT FOR 126A1LN EQUALIZER BOLT
6-113	100000	3/4"-10	LOCKNUT FOR 7-135-2 10K GD SPRING EYE BOLT
090637	100400	3/4"-16	LOCKNUT FOR HAYES 090747 10K SPRING EYE BOLT
6-113DLN	079200	3/4"-10	U-BOLT LOCKNUT FOR 11-70LN U-BOLT
78CN	098400	7/8"-9	CASTLE NUT FOR 7845B EQUALIZER BOLT
6-111	098425	7/8"-9	LOCKNUT FOR 7-1-1 EQUALIZER BOLT
6-112	100600	1"-8	LOCKNUT FOR 7-182, 7-169 BOLTS
090636	100800	1"-14	LOCKNUT FOR HAYES 10K EQUALIZER BOLT
6-72	101000	1 1/8"-7	LOCKNUT FOR 10K, 12K, 15K, 7-170 EQUALIZER BOLT



**Suspension Replacement Parts:**  
*The Most Commonly Asked For Suspension Parts  
in Attractive Showroom Packaging!*



**Packaged U-Bolts**



Part No.	Ref. No.	Description	Code
SP01-020	071050	1 3/4" ROUND, W/NUT, 3/8" DIAMETER, 4 1/4" LONG (QTY 2)	B
SP01-040	071060	2 3/8" ROUND, W/NUT, 1/2" DIAMETER, 5 1/2" LONG (QTY 2)	A
SP01-060	071070	3" ROUND W/NUT, 1/2" DIAMETER, 7" LONG (QTY 2)	A
SP01-080	071080	3" ROUND W/NUT, 9/16" DIAMETER, 7 1/4" LONG (QTY 2)	B
SP01-100	071085	3 1/2" ROUND W/NUT, 9/16" DIAMETER, 8" LONG (QTY 2)	B
SP01-120	071090	1 1/2" SQUARE W/NUT, 1/2" DIAMETER, 5" LONG (QTY 2)	B
SP01-140	071100	1 3/4" SQUARE W/NUT, 9/16" DIAMETER, 5" LONG (QTY 2)	B
SP01-160	071110	2" SQUARE W/NUT, 9/16" DIAMETER, 5 3/4" LONG (QTY 2)	A



**Packaged Shackle Straps**



PART NO.	REF. NO.	DESCRIPTION	CODES
SP03-020	101550	2 1/4" HOLE CENTER, 1 1/4" WIDE, 9/16" HOLE (QTY 4)	B
SP03-040	101560	2 5/8" HOLE CENTER, 1 1/4" WIDE, 9/16" HOLE (QTY 4)	A
SP03-060	101570	3 1/8" HOLE CENTER, 1 1/4" WIDE, 9/16" HOLE (QTY 4)	B



**Packaged Bolts and Nuts**



PART NO.	REF. NO.	DESCRIPTION	CODES
SP04-020	094500	9/16" X 3" SHACKLE BOLT WITH NUT FOR 1 3/4" WIDE SPRINGS (QTY4)	A
SP04-040	094510	9/16" X 3 1/2" SHACKLE BOLT WITH NUT FOR 2" WIDE SPRINGS (QTY 4)	B
SP04-060	094520	7/8" X 4 11/16" EQUALIZER BOLT & NUT, WITH COTTER PIN (QTY 1)	C
SP04-080	094530	7/8" X 4 11/16" EQUALIZER BOLT & NUT, WITH ZERK PRESSED IN (QTY 1)	C
SP04-021	094505	9/16" X 3" WET SHACKLE BOLT W/ NUT & ZERK (QTY 4)	C
SP04-051	094515	3/4" X 3 1/2" WET EQUALIZER BOLT W/ NUT, ZERK & COTTER PIN (QTY 2)	C



**Packaged Bushings**



PART NO.	REF. NO.	DESCRIPTION	CODES
SP05-020	103710	NYLON, 9/16" ID, 11/16" OD, 1 3/4" LONG (QTY 8)	A
SP05-040	103720	NYLON, 9/16" ID, 11/16" OD, 2" LONG (QTY 8)	B
SP05-060	103730	NYLON, 9/16" ID, 3/4" OD, 1 3/4" LONG (QTY 6)	B
SP05-080	103740	2 PIECE NYLON, 9/16" ID, 1 5/16" OD, 2" LONG (QTY 4)	C

**H-9700**



**22,400 lb. and 24,000 lb.**

**Heavy Duty Suspensions**

*The World's #1 Selling Suspension*

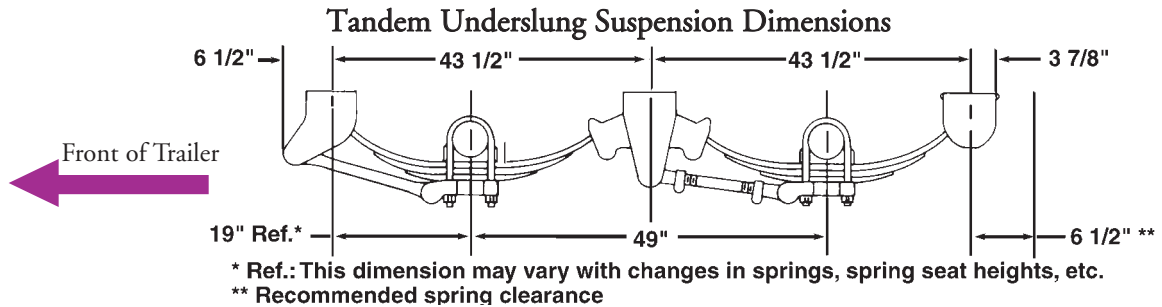

SUSPENSIONS

When looking for a heavy duty, economical, versatile, low maintenance suspension that maximizes your payload and has after market parts readily available - *Hutch is the one for you.*

Hutchens Industries has many variations to fit your special needs. Redneck stocks the most common suspension for our trailer industry, a fabricated (Fab), underslung (US) suspension with 49" axle spacing, undermount hangers (UN/MT) for 5" round axles with a 3/4" seat height providing a 7" ride height. (Allow 4 1/2" min. clearance above the tires and 3" above the U-bolts.)

Part No.	Ref. No.	Hanger Type	No. of Axles	Axle Config.	Axle Center	Hanger Style	Type Axle	Seat Height	Spring Type
H7700HUS-354	043175	FAB	SINGLE	US	49"	UN/MT	5" RD	3/4"	354-00
H9700TUS-354	043205	FAB	TANDEM	US	49"	UN/MT	5" RD	3/4"	354-00
H9700ADD-354	043215	FAB	ADD-ON*	US	49"	UN/MT	5" RD	3/4"	354-00
HAP-101-00	043225	FAB	SINGLE	US	49"	UN/MT	5" RD	3/4"	WITHOUT
HAP-201-00	043300	FAB	ADD-ON*	US	49"	UN/MT	5" RD	3/4"	WITHOUT
10521-00	043400	BUMP-OUT BLOCK FOR HUTCH TRIAXLE SUSPENSION (NEED 4 FOR TRIAXLE)							

\* An Add-on suspension kit is used to convert a single axle suspension into a tandem or a tandem into a triaxle.

When ordering Hutch suspensions that Redneck may not stock, use the following chart and the help of your Redneck branch. Redneck can deliver any combination you might need.

<b>What to know when ordering a Custom Hutch Suspension</b>										
<b>Hanger Type:</b>	Cast	Fabricated (FAB)			<b>Hanger Style*:</b>			UN/MT	ST/MT	
<b>Number of Axles:</b>	Single	Tandem	Tri					FL/MT/BO	FL/MT/WO	
<b>Type of Axle:</b>	5" RD	5x5 SQ	4x6					UN/MT I-BEAM	SI/MT	
<b>Axle Centers:</b>	49"	other			<b>Spring Number or Type:</b>					
<b>Axle Configuration:</b>		Overslung (OS)	Underslung (US)		Leaves	GAWR	High Arch	Med. Arch	Low Arch	
<b>Axle or Spring Seat Height:</b>		3/4"	1 1/4"	1 3/4"	3	22.4 k	354-00	355-00	356-00	
					3	24.0 k	365-00	N/A	365-01	
					7	22.4 k	751-05	N/A	751-01	
					8	24.0 k	752-05	N/A	752-01	
		3/4"	1 1/4"	1 3/4"	2 1/4"	2 3/4"	3 1/4"	4 1/4"	4 1/4"	4 3/4"

\* Under Mount (UN/MT), Straddle Mount (ST/MT), Side Mount (SI/MT), Flange Mount (FL/MT)



**RIDEWELL AIR-RIDE  
Trailer Suspensions**

**Model RAR-240: Monopivot Underslung  
Capacity: 10,000 – 25,000 lbs.**

**Low Maintenance Features:**

- Exclusive Contoured Axle Seat optimizes Axle Weldment.
- No U-bolts Required, eliminating Weight and Maintenance.
- Double-Bonded Bushing with Manual Clamp-in Feature gives Long Service Life.
- Only Hand Tools required for Bushing Mounting or Removal.
- Simple, Manually Adjustable Axle Alignment by Ridewell's Patented Eccentric Bolt.

**Suspension No. 2407709D001**

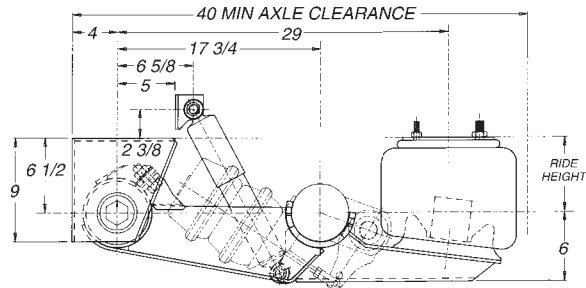

Designed for 10,000 – 15,000 lb. Axles

**Suspension No. 2407744D106**

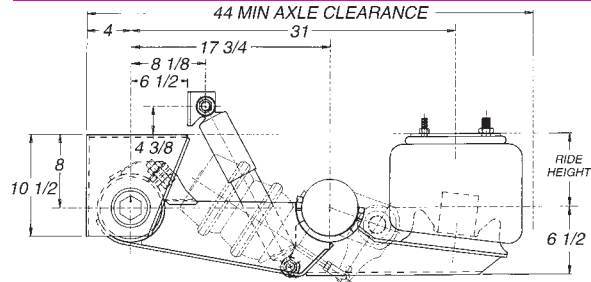

Designed for 22,500 – 25,000 lb. Axles

**Suspensions**

Part No.	Ref. No.	Maximum Capacity	Axle Size	Ride Height	Axle Travel Up	Axle Travel Down	Minimum Axle Spacing
2407709D001	043600	15,000	5"	MIN: 5 1/2" MAX: 6"	2 1/2" 3"	3 1/2" 3"	40"
2407744D106	043650	25,000	5"	MIN: 6 1/2" MAX: 7 "	2 3/4" 3 1/4"	3 3/4" 3 1/4"	44"

**Air Control Kits (1 Required Per Trailer):**

Part No.	Ref. No.	Description
1207423C100	043700	HEIGHT CONTROL VALVE (ONE REQUIRED PER TRAILER WITH UP TO 3 AXLES)
1220001	043750	AIR COMPRESSOR KIT WITH AIR TANK (FOR TRAILERS W/O AIR SUPPLY). NOTE: 1207423C100 NOT INCLUDED.

The following table shows the minimum hubface and axle wall thickness to be used with the Ridewell Air-Ride suspensions.

Axle Model	Wall Thickness	S-Cam Length	Min. Hubface
10K HD	.44"	22.312"	66.50"
12K Hi-Profile	.44"	22.312"	66.62"
12K Lo-Profile	.44"	22.312"	73.12"
15K	.44"	22.312"	69.04"
20K + w/12.25" Brake	.62"	22.312"	69.50"*
20K + w/16.50" Brake	.62"	23.437"	71.00"*

\*Reminder: All 10K - 15K axles are ordered by "hubface", & all 20K & up are ordered by "track"

When ordering Ridewell suspensions that Redneck may not stock, use the following chart and the help of your Redneck branch. Redneck can deliver any combination you might need.

<b>What to know when ordering a custom Ridewell Suspension</b>			
Lift Kit:	Yes	No	Capacity per Axle
Axle Size:	5" OD by 5/8" Wall	Other	Mounting Height
			10,000 lbs. to 30,000 lbs. 5 1/2" to 24"

# Red Rider

## Air Ride Suspension

Manufactured by:



**PROTECTION:**

Full featured 8,000 lb. capacity air ride; cushions & protects the towing vehicle, the trailer and its cargo.

**COMPACT DESIGN:**

The compact design fits standard size fender envelope and maintains a low-ride height.

**ADJUSTABLE ALIGNMENT:**

Ability to align the axles during installation to ensure proper handling & performance.

**AUTOMATIC:**

Height control valve; compressor & air tank automatically and instantly maintain trailer ride height setting.

**EASE OF USE:**

Optional dump valve offers the ability to release the air from the springs to aid in loading & unloading of cargo.

**LOW MAINTENANCE:**

No bolts to re-torque. Replaceable parts are readily available at most HD truck parts stores.

**RELIABILITY:**

Designed and manufactured by Ridewell Suspensions, who have 50 years of Air Ride Suspension experience.

**AVAILABILITY:**

Distributed exclusively by Redneck Trailer Supplies.

SUSPENSIONS

### Red Rider Suspension

Part No.	Ref. No.	Max. Capacity	Axle Size	Ride Height	Axle Travel		Min. Axle Spacing
					Up	Down	
2440001	043500	8,000	3.5"*	6"	2.1"	2.5"	32"

\*3.5" O.D. 1/2" wall axle option required, available on 6K, 7K & 8K Dexter Axles

### RedRider Control Kits

Part No.	Ref. No.	Description
1200001	043675	Control kit, includes 12V compressor & Jr. Height control valve (for trailers w/o air supply)
1200032 *	043680	man. dump valve, lowers suspension for easier unloading & loading of trailer
1200031 *	043685	12V elect dump valve, lowers suspension for easier unloading & loading of trailer
1247740C000	043725	Jr Height control valve only (One required per trailer w/air supply, up to 3 axles)

\*Dump valves can also be used on air-ride suspensions shown on page D-24



#### Attn: OEM's

Weldment Fixture (jig) available for easier faster installations! Call your local Redneck Branch for more information. Fixture #6100018

# Firestone

## Ride-Rite®

### air helper springs

Ride-Rite® air helper springs can be installed on most light trucks, RV's and vans. Ride-Rite air helper-springs are installed between the frame of the vehicle and the suspension providing load support through the use of air pressure.



Firestone has made a commitment to provide the customer with the best air helper spring kits in the industry. Ride-Rite has become synonymous with quality, durability and with customer support truly second to none.

Ride-Rite air helper springs utilize a pair of convoluted or tapered style air springs. These air springs are capable of \*3,000 - 5,000 lbs of load carrying capacity per set. It is extremely important to remember that the air helper springs do not increase a vehicle's carrying capacity. Although the air springs are capable of lifting a great deal of weight they are intended to maximize the vehicle's load capabilities within the recommended Gross Vehicle Weight Rating.

\* Do NOT exceed the vehicle's recommended Gross Vehicle Weight Rating (GVWR)

#### Ride Rite Suspensions\*

Part No.	Ref. No.	Description
AS2071	043900	Ride-Rite, 73-87 Chevy PU, 63-96 Ford PU & 98-01 Ford SD, 77-01 Dodge PU
AS2025	043920	Ride-Rite for 88-00 Chevy PU (except 99-00 Silverado)
AC2158	044055	Ride-Rite Kit, works both air springs together
AC2168	044060	Ride-Rite Kit, works air springs separately

\* Additional model applications available by special order.



#### Basic Kit:

Everything is included for a quick installation. Brackets, air springs, hardware and inflation valves for manual inflation. Average installation time is approximately 1-2 hours.

#### Ride-Rite air helper springs will:

Keep the vehicle front end down - improve steering control, level headlight beams and improve tire wear.

Level off-center loads - individual inflation valves allow for adjustment side-to-side and front-to-rear.

Reduce suspension fatigue - keep leaf springs from sagging under repeated or constant load.

Air adjustment improves the ride - allowing the air springs to be matched to the load.

Reduce bottoming out - protective air cushion softens contact between the axle and frame.

Increase vehicle stability - absorbing road shock providing ideal ride conditions for passengers and load.

#### Control Kit:

Ride-Rite control kits provide instant ride control within the cab of the vehicle. They allow quick inflation and deflation for various road and load conditions.







TIRES &  
WHEELS

## Tires & Wheels

Selection of the right tires and wheels is one of the most important decisions a trailer builder must make. We offer a wide range of tires and wheels to meet your needs, along with helpful technical information to help you make the best decisions possible.

### Definition of Tire Terms

**Design Rim Width:** "Design Rim Width" is the specific rim width assigned to each tire size designation to determine basic tire dimensions.

**Section Width:** "Section Width" is the maximum width of a new tire.

**Overall Diameter:** "Overall Diameter" is the diameter of an inflated tire at the outermost surface of the tread.

**Maximum Load Capacity:** "Maximum Load Capacity" is the maximum weight a tire is designed to carry under standard use conditions.

**Load Identification:**

**Load Range** with a letter (A, B, C, etc.), **Standard Load** and **Extra Load** are used to identify a given size tire with its load and inflation limits when used in a specific type of service.

**Ply Rating** is a term used to identify a given tire with its maximum recommended load when used in a specific type of service. It is an index of tire strength and does not necessarily represent the number of cord plies in the tire.

**Static Load Radius:** "Static Load Radius" is the dimension from the bottom of the tire to the center line of an axle when the tire is loaded at its rated capacity.

**How The Tire Part Number System Works:** The Part Numbers incorporate tire sizes and descriptions to allow you to easily determine the tires you need to order. For example, part numbers 7516BD and P215-75-R15BB can be interpreted as follows:

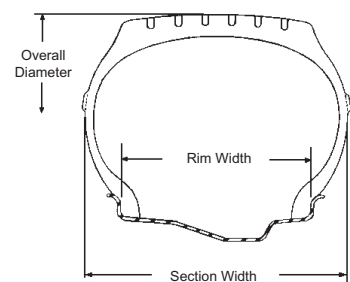
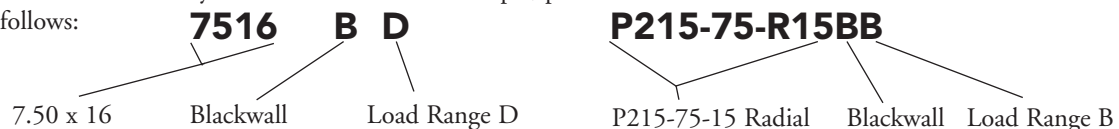



## Goodyear Marathon Radial 13" - 15" Trailer Tires

Realizing the need for "extra capacity" tires to fit the demanding applications of many Marine, Utility and R.V. trailers today, Goodyear offers Marathon "ST" Radial Trailer Tires. Technical information is provided below.



Part No.	Ref. No.	Description	L.R.	O.D.	Sec. Width	Rim Width	Max. Load Cap. Single	Load Radius
ST175-80-R13BC	337830	ST175-80-R13, Blackwall	C	24.0	7.0	5.0	1360 @ 50	11.2
ST205-75-R14BC	338240	ST205-75-R14, Blackwall	C	26.1	8.0	5.5	1760 @ 50	12.1
ST205-75-R15BC	338320	ST205-75-R15, Blackwall	C	27.1	8.0	5.5	1820 @ 50	12.6
ST225-75-R15BC	338450	ST225-75-R15, Blackwall	C	28.3	8.8	6.0	2150 @ 50	13.0
ST225-75-R15BD	338470	ST225-75-R15, Blackwall	D	28.3	8.8	6.0	2540 @ 65	13.0
ST235-80-R16BD	338500	ST235-80-R16, Blackwall	D	30.8	9.2	6.5	3000 @ 65	14.0

## 14.5" - 17.5" Diameter Heavy Duty Trailer Tires

TIRES & WHEELS

Every trailer builder requires a tire specifically designed for a long-lasting, heavy duty application. We have the tires to fit these needs. This group includes sizes from the popular 700 x 15 to as large as 17.5".



Part No.	Ref. No.	Description	L.R.	O.D.	Sec. Width	Rim Width	Max. Load Cap. Single / Dual	Load Radius
800145BF	338900	800 x 14.5 LT NYLON BLACKWALL	F	28.2	8.0	6.0	2790 @ 100 / 2460 @ 100	13.3
900145BF	338950	900 x 14.5 LT NYLON BLACKWALL	F	28.3	9.7	7.0	3230 @ 100 / 2840 @ 100	13.3
7015BC	339000	700 x 15 NYLON BLACKWALL	C	29.8	8.3	5.5	1720 @ 45 / 1520 @ 45	13.8
7015BD	339200	700 x 15 NYLON BLACKWALL	D	29.8	8.3	5.5	2040 @ 60 / 1800 @ 60	13.8
7516BD	339400	750 x 16 NYLON BLACKWALL	D	31.6	8.9	6.0	2440 @ 60 / 2140 @ 60	14.8
7516BE	339425	750 x 16 NYLON BLACKWALL	E	31.6	8.9	6.0	2780 @ 75 / 2440 @ 75	14.8
LT21585R16BE	339440	LT215-85R-16, RADIAL BLACKWALL	E	30.5	8.5	6.0	2680 @ 80 / 2470 @ 80	14.1
LT23585R16BE	339450	LT235-85R-16, RADIAL BLACKWALL	E	31.5	9.2	6.5	3042 @ 80 / 2778 @ 80	14.5
LT23585R16BG	339510	LT235-85R-16, RADIAL BLACKWALL	G	30.8	9.5	6.0	3750 @ 110 / 3415 @ 110	14.3
LT24575R16BE	339550	LT245-75R-16, RADIAL BLACKWALL	E	30.6	9.8	7.0	3042 @ 80 / 2778 @ 80	14.0
875165BD	339600	8.75 x 16.5 NYLON BLACKWALL	D	29.2	8.8	6.75	2350 @ 60 / 2070 @ 60	13.6
875165BE	339800	8.75 x 16.5 NYLON BLACKWALL	E	29.2	8.8	6.75	2680 @ 75 / 2360 @ 75	13.6
950165BD	340000	9.50 x 16.5 NYLON BLACKWALL	D	30.3	9.6	6.75	2780 @ 60 / 2445 @ 60	14.0
950165BE	340200	9.50 x 16.5 NYLON BLACKWALL	E	30.3	9.6	6.75	3170 @ 75 / 2790 @ 75	14.0
1200165BF	340300	12.00 x 16.5 NYLON BLACKWALL	F	31.6	12.1	9.75	4045 @ 75 / 3560 @ 75	14.9
215-75R-175H	340610	215-75R-17.5 BLACKWALL	H	30.6	8.4	6.0	4805 @ 125 / 4540 @ 125	14.0
235-75R-175H-G	340640	235-75R-17.5 BLACKWALL	H	31.8	9.2	6.75	6005 @ 125 / 5675 @ 125	14.5

**BRIDGESTONE**
**Firestone**
**SEIBERLING**

 TIRES &  
 WHEELS

Part No.	Ref. No.	Description	L.R.	O.D.	Sec. Width	Rim Width	Max. Load Cap. Single / Dual	Load Radius
800145BF-S	338910	8.00-14.5 LT, BLACKWALL	F	27.8	8.0	6.0	2790 @ 100 / 2460 @ 100	13.4
7015BC-S	339010	700 x 15 LT, BLACKWALL	C	29.6	8.0	5.0	1720 @ 45 / 1520 @ 45	13.7
7015BD-S	339210	700 x 15 LT, BLACKWALL	D	29.6	8.0	5.0	2040 @ 60 / 1800 @ 60	13.7
LT21585R16BE-F	339444	LT215-85R-16, FIRESTONE STEELTEX R4S RADIAL	E	30.4	8.5	6.0	2680 @ 60 / 2470 @ 60	13.5
LT23585R16BE-F	339448	LT235-85R-16, FIRESTONE STEELTEX R4S RADIAL	E	31.7	9.4	6.5	3042 @ 80 / 2778 @ 80	14.0
7516BD-S	339410	750 x 16 LT, BLACKWALL	D	31.8	8.7	6.0	2440 @ 60 / 2140 @ 60	14.7
875165BD-S	339610	8.75 x 16.5 LT, BLACKWALL	D	29.7	9.0	6.75	2350 @ 60 / 2070 @ 60	13.8
950165BD-S	340210	9.50 x 16.5 LT, BLACKWALL	D	30.6	9.6	6.75	2780 @ 60 / 2445 @ 60	14.4
215-75R-175H-B	340620	215-75R-17.5, BLACKWALL RADIAL	H	30.6	8.5	6.0	4805 @ 125 / 4540 @ 125	14.3
235-75R-175H	340630	235-75R-17.5, BLACKWALL RADIAL	H	31.6	9.5	6.75	6005 @ 125 / 5675 @ 125	14.8

### Value Priced Steel Belted Radials

Part No.	Ref. No.	Description	L.R.	O.D.	Sec. Width	Rim Width	Max. Load Cap. Single / Dual	Load Radius
P175-80-R13WB	337825	*P175-80-R13, WHITEWALL	B	24.1	6.7	5.0	1179 @ 35 / NA	10.7
P205-75-R14WB	338225	*P205-75-R14, WHITEWALL	B	26.3	7.8	5.5	1532 @ 35 / NA	11.6
P205-75-R15WB	338315	*P205-75-R15, WHITEWALL	B	27.3	7.6	5.5	1598 @ 35 / NA	12.1
P215-75-R15WB	338400	*P215-75-R15, WHITEWALL	B	27.9	8.2	6.0	1742 @ 35 / NA	12.3
LT21585R16BD-S	339443	LT215-85R-16, BLACKWALL	D	30.4	8.5	6.0	2335 @ 60 / 2150 @ 60	14.2
LT23585R16BE-S	339445	LT235-85R-16, BLACKWALL	E	31.7	9.3	6.0	3042 @ 80 / 2778 @ 80	14.7

\* For passenger ("P-metric") tires used in trailer applications, the Tire and Rim Association specifies that selection of size and load range on each axle shall be based on the highest individual wheel load multiplied by a service factor of 1.10. The load so obtained shall not be greater than the Tire Maximum Load of the passenger tire.

## Bias Ply Trailer Tires

Our line of 78 series "ST" tires offers the perfect balance of product performance and value. These tires are competitively priced and are backed by a nationwide manufacturer's warranty.

Part No.	Ref. No.	Description	L.R.	O.D.	Sec. Width	Rim Width	Max. Load Cap.	Single	Load Radius
B78-13BB	341000	B78-13 SPECIAL TRAILER BIAS TIRE, BLACKWALL	B	24.2	6.9	5.0	1100 @ 35		12.1
B78-13BC	341010	B78-13 SPECIAL TRAILER BIAS TIRE, BLACKWALL	C	24.2	6.9	5.0	1360 @ 50		12.1
F78-14BB	341050	F78-14 SPECIAL TRAILER BIAS TIRE, BLACKWALL	B	26.6	7.9	5.5	1430 @ 35		13.3
F78-14BC	341060	F78-14 SPECIAL TRAILER BIAS TIRE, BLACKWALL	C	26.6	7.9	5.5	1760 @ 50		13.3
F78-15BC	341100	F78-15 SPECIAL TRAILER BIAS TIRE, BLACKWALL	C	27.6	7.4	5.5	1820 @ 50		13.8
H78-15BC	341110	H78-15 SPECIAL TRAILER BIAS TIRE, BLACKWALL	C	28.6	8.5	6.0	2150 @ 50		14.3
H78-15BD	341120	H78-15 SPECAIL TRAILER BIAS TIRE, BLACKWALL	D	28.6	8.5	6.0	2540 @ 65		14.3

## Small Diameter Tire and Wheel Assemblies



We offer 8", 10" and 12" Tire and Painted Wheel Assemblies for many applications, all are available with 4 on 4" or 5 on 4.5" bolt patterns. Many are also available on Galvanized Wheels.

Part No.	Ref. No.	Load Range	O.D.	Sect. Width	Tire Size	Max Load Cap.	Max PSI.	Finish
480TW4-B	341800	B	16.7	4.6	4.80-8	590	60	PAINTED
480TW4GV-B	341900	B	16.7	4.6	4.80-8	590	60	GALVANIZED
480TW5-B	342000	B	16.7	4.6	4.80-8	590	60	PAINTED
480TW5GV-B	342100	B	16.7	4.6	4.80-8	590	60	GALVANIZED
578TW4-B	342200	B	18.6	5.6	5.70-8	715	50	PAINTED
578TW5-B	342400	B	18.6	5.6	5.70-8	715	50	PAINTED
1656TW5-B	342450	B	16.7	6.5	16.5 x 6-8	620	45	PAINTED
1858TW5-B	342475	B	18.2	8.4	18.5 x 8-8	770	35	PAINTED
1858TW5GV-B	342600	B	18.2	8.4	18.5 x 8-8	770	35	GALVANIZED
2058TW5-B	342800	B	20.4	8.0	20.5 x 8-10	905	35	PAINTED
2058TW5GV-B	342900	B	20.4	8.0	20.5 x 8-10	905	35	GALVANIZED
2058TW5-C	343000	C	20.4	8.0	20.5 x 8-10	1105	50	PAINTED
2058TW5GV-C	343050	C	20.4	8.0	20.5 x 8-10	1105	50	GALVANIZED
2058TW5-D	343100	D	20.4	8.0	20.5 x 8-10	1330	70	PAINTED
2058TW5GV-D	343150	D	20.4	8.0	20.5 x 8-10	1330	70	GALVANIZED
2058TW5-E	343200	E	20.4	8.0	20.5 x 8-10	1535	90	PAINTED
4812TWSPK4-B	343600	B	21.3	5.2	4.80-12	780	60	PAINTED
4812TWSPK4GV-B	343800	B	21.3	5.2	4.80-12	780	60	GALVANIZED
4812TWSPK5-B	344000	B	21.3	5.2	4.80-12	780	60	PAINTED
4812TWSPK5GV-B	344010	B	21.3	5.2	4.80-12	780	60	GALVANIZED

## Custom Trailer Wheels

Our wheels are designed, manufactured and tested to provide service and performance that is the standard of the industry. These wheel designs are subjected to destructive "torture" testing to simulate extreme service and overload conditions. Spoke and Modular wheels not only offer a custom look, they have capacities that meet or exceed the O.E.M. design and are economical to use.

### Wheel Selection How-To's

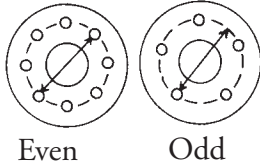

Even

Odd

A great deal of thought and consideration should be given when selecting trailer wheels. Important choices must be made from the various wheels on the market. When combining wheels, tires, hubs and axles, the load carrying capacity is limited to whichever component has the lowest capacity. Load capacities relate specifically to generally accepted standard axle applications for conventional trailers used in normal highway service, loaded equally side-to-side. Unusual axle configurations, unequal fore and aft loading, or overload conditions can cause premature failure of wheels, tires and/or other parts.

#### How To Determine Bolt Pattern:

Match wheels to hubs by the number of bolts and bolt circle. To determine the bolt circle on wheels with an even number of bolt holes, measure center-to-center on bolt holes directly across from each other on the diameter (Example: 8 on 6 1/2 would mean 8 bolt holes with 6 1/2" center-to-center diameter). On odd number bolt wheels, measure any bolt hole center to the point halfway between bolt holes on the diameter (Example: 5 on 4 1/2 would mean 5 bolt holes with 4 1/2" measure to a point halfway between the opposite bolts).

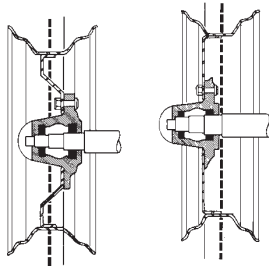

Outset

Inset

#### How to Determine Wheel Offset:

Offset is the distance between the mounting face of the disc and rim centerline.

**Inset:** Refers to the distance when the mounting face is outboard of the rim centerline

**Outset:** Refers to the distance when the mounting face is inboard of the rim centerline.

### Modular Trailer Wheels

Part No.	Ref. No.	Diameter & Width	Capacity	Offset	Bolt Pattern	Pilot Diameter	Paint Color
17-229-7	326020	13" x 4.5"	1360	0	5 on 4 1/2	3.19	WHITE
17-230-7	326030	14" x 5.5"	1870	0	5 on 4 1/2	3.19	WHITE
17-231-7	326035	15" x 5"	1820	0	5 on 4 1/2	3.19	WHITE
17-232-7	326040	15" x 6"	2050	0	5 on 4 1/2	3.19	WHITE
WH156-5SM	326045	15" x 6"	2150	0	5 on 4 1/2	3.30	SILVER
17-233-7	326050	15" x 6"	2600	0	6 on 5 1/2	4.27	WHITE
WH156-6SM	326060	15" x 6"	2600	0	6 on 5 1/2	4.27	SILVER
17-255-7	326065	16" x 6"	3040	0	6 on 5 1/2	4.27	WHITE
17-281-7	326075	16" x 6"	3750	.50 IN	8 on 6 1/2	4.90	WHITE
WH166-8SM	326077	16" x 6"	3750	0	8 on 6 1/2	5.15	SILVER
17-281-19	326078	16" x 6"	3750	.50 IN	8 on 6 1/2	4.90	SILVER
17-280-7	326085	16.5" x 6.75"	3530	.50 IN	8 on 6 1/2	4.90	WHITE



### White Spoke Wheels

Part No.	Ref. No.	Diameter & Width	Capacity	Offset	Bolt Pattern	Pilot Diameter
17-213-7	326095	12" x 4"	1045	0	4 on 4	2.84
17-214-7	326100	12" x 4"	1045	0	5 on 4 1/2	3.19
17-201-7	326150	13" x 4.5"	1100	0	4 on 4	2.62
17-189-7	326200	13" x 4.5"	1360	0	5 on 4 1/2	3.19
17-142-7	326225	14" x 5.5"	1870	0	5 on 4 1/2	3.19
17-143-7	326230	15" x 5"	1820	0	5 on 4 1/2	3.19
17-149-7	326235	15" x 6"	2050	0	5 on 4 1/2	3.19
WH156-5475WS	326250	15" x 6"	2150	0	5 on 4 3/4	3.30
WH156-550WS	326255	15" x 6"	2050	0	5 on 5	3.30
17-144-7	326275	15" x 6"	2600	0	6 on 5 1/2	4.27
17-243-7	326290	16" x 6"	3040	0	6 on 5 1/2	4.27
17-162-7	326300	16" x 6"	3750	0	8 on 6 1/2	4.90
17-163-7	326375	16.5" x 6.75"	3530	0	8 on 6 1/2	4.90



## Chrome Wheels



Chrome Wheels have all of the features and benefits of the Painted Wheels with a bright chrome plated finish.

Available in eight spoke or 10-hole modular versions.



Part No.	Ref. No.	Diameter & Width	Capacity	Style	Offset	Bolt Pattern	Pilot Diameter
WH1355-5CS	327600	13" x 5 1/2"	1315	SPOKE	0	5 ON 4 1/2	2.95
WH146-5CS	327800	14" x 6"	1865	SPOKE	0	5 ON 4 1/2	3.30
WH146-5CM	327900	14" x 6"	1865	MOD	0	5 ON 4 1/2	3.30
WH156-5CS	328000	15" x 6"	2050	SPOKE	0	5 ON 4 1/2	3.30
WH156-6CS	328200	15" x 6"	2050	SPOKE	0	6 ON 5 1/2	4.28
WH166-8CS	328400	16" x 6"	3000	SPOKE	0	8 ON 6 1/2	5.15
WH166-8CM	328500	16" x 6"	3000	MOD	0	8 ON 6 1/2	5.15

## Aluminum Modular Wheels

These great looking wheels have been designed from the ground up, specifically for trailer use. They all feature steel hole inserts and are individually boxed. A wet clear coat finish ensures long lasting corrosion resistance. All are covered by a 3 year limited manufacturer's warranty.



Part No.	Ref. No.	Diameter & Width	Capacity	Offset	Bolt Pattern	Pilot Diameter
WH1455-5A	326700	14" x 5.5"	1900@50 PSI	0	5 on 4 1/2	3.19
WH156-5A	326710	15" x 6"	2150@50 PSI	0	5 on 4 1/2	3.19
WH156-6A	326720	15" x 6"	2540@65 PSI	0	6 on 5 1/2	4.28
WH167-6A	326730	16" x 7"	3100@80 PSI	.31 OUT	6 on 5 1/2	4.28
WH167-8A	326740	16" x 7"	3100@80 PSI	.31 OUT	8 on 6 1/2	5.15

## Galvanized Spoke Trailer Wheels

These galvanized spoke wheels are perfect for salt water marine trailers or any situation that demands added corrosion resistance. Choose the size that best fits your needs.



Part No.	Ref. No.	Diameter & Width	Capacity	Offset	Bolt Pattern	Pilot Diameter
WH1345-5GVS	328700	13" x 4 1/2"	1360	.19 IN	5 on 4 1/2	3.30
WH146-5GVS	328720	14" x 6"	1880	.60 IN	5 on 4 1/2	3.30
WH156-5GVS	328740	15" x 6"	2050	.60 IN	5 on 4 1/2	3.30
WH156-6GVS	328750	15" x 6"	2600	.60 IN	6 on 5 1/2	4.25

## Utility Rims

Many utility trailers have been equipped with "UTG" or utility type axles that require a 14.5" diameter rim. We have 2 widths available, 6.00" and 7.00". These rims are specifically manufactured for trailer use.



Part No.	Ref. No.	Diameter & Width	Capacity	Bolt Pattern
17-53	333000	14.5" x 6"	3000	RIM
17-48	333020	14.5" X 7"	3500	RIM

## O.E.M. Single Wheels

O.E.M. design wheels have been the standard wheels used on trailers for many years. They offer the appearance, strength and simplicity that many customers prefer. We offer O.E.M. design wheels in sizes from 8" to 17.5" diameter.

Part No.	Ref. No.	Diameter & Width	Capacity	Offset	Bolt Pattern	Pilot Diameter	Hub Cap
WH84-40E	321800	8" x 3.75"	715	0	4 ON 4	2.50	1102
WH84-50E	322000	8" x 3.75"	715	0	5 ON 4 1/2	2.89	1102
WH106-40E	322200	10" x 6"	1535	0	4 ON 4	2.50	1102
WH106-50E	322400	10" x 6"	1535	0	5 ON 4 1/2	2.81	1102
WH1345-40E	323000	13" x 4.5"	1250	.25 IN	4 ON 4	2.50	1102
WH1345-50E	323200	13" x 4.5"	1480	.50 IN	5 ON 4 1/2	2.62	1308
WH1455-50E	323400	14" x 5.5"	1865	.50 IN	5 ON 4 1/2	2.62	1308
WH155-50E	323600	15" x 5"	1820	.50 IN	5 ON 4 1/2	2.62	1308
WH156-50E	323625	15" x 6"	1820	.50 IN	5 ON 4 1/2	2.62	1308
WH156-60E	323800	15" x 6"	2600	0	6 ON 5 1/2	3.65	1306
WH166-60E	324200	16" x 6"	3040	0	6 ON 5 1/2	3.65	1309
17-153	324400	16" x 6"	3500	.50 IN	8 ON 6 1/2	4.89	1309
17-302	324500	16" x 6"	3750	.50 IN	8 ON 6 1/2	4.89	N/A
17-154	324600	16.5" x 6.75"	3530	.50 IN	8 ON 6 1/2	4.89	1309
WH165975-8HD	325200	16.5" x 9.75"	4000	.50 IN	8 ON 6 1/2	4.78	N/A
17-241	324700	17.5" X 6.75"	6200	.19 IN	8 ON 6 1/2	4.75	N/A
17-240	325425	17.5" x 6.75"	6200	.31 OUT	8 ON 6 1/2	4.75	N/A
17-298	325430	17.5" x 6.75"	6200	.50 OUT	8 ON 6 1/2	4.75	N/A
WH175825-80E	325600	17.5" x 8.25"	5000	.31 OUT	8 ON 6 1/2	4.75	N/A



TIRES & WHEELS

## O.E.M. Dual Wheels and Rims

Because of the increasing use of dual wheel axles, it has become very important that we be able to supply our customers with wheels that complement the axles and tires used in any given application. We feel the group of Dual Wheels and Rims listed below will fit your needs. We offer wheels and rims in diameters from 14.5" to 22.5" with various designs and capacities.

Part No.	Ref. No.	Diameter & Width	Capacity	Offset	Bolt Pattern	Pilot Diameter
WHDD145700-80E	328800	14.5" x 7"	3000	5.65 OUT	8 ON 6 1/2	4.75
WHCD166-80E	329200	16" x 6"	3000	5.00 OUT	8 ON 6 1/2	4.56
17-279	329500	16" x 6"	3000	5.50 OUT	8 ON 6 1/2	4.75
WHDS166-80E	329550	16" x 6"	3000	5.50 OUT	8 ON 6 1/2	4.75
WHFD166-80E	329600	16" x 6"	2140	5.00 OUT	8 ON 6 1/2	4.86
WHHD166-80E	329675	16" x 6"	2500	5.00 OUT	8 ON 6 1/2	4.88
17-157	330200	16.5" x 6.75"	3000	5.50 OUT	8 ON 6 1/2	4.75
WHFD165675-80E	330400	16.5" x 6.75"	2445	5.375 OUT	8 ON 6 1/2	4.86
WHD175675-100E	330600	17.5" x 6.75"	5070	6.19 OUT	10 ON 8 3/4	6.50
WHD225825-100E	330800	22.5" x 8.25"	6800	6.625 OUT	10 ON 11 1/4	8.718
R175675	331600	17.5" x 6.75"	4710	N/A (RIM)	N/A	N/A
R225825	332000	22.5" x 8.25"	7200	N/A (RIM)	N/A	N/A



### QuickTrim® ABS Trailer Hub Covers

QuickTrim® ABS Chrome Hub Covers are a handsome alternative to bare hubs or push-through center caps. Features easy snap-on installation and four convenient sizes. Also available in low cost black ABS plastic.



Part No.	Ref. No.	Bolt Pattern	Color	Lug Size
QT545CHC	335400	5 on 4 1/2	Chrome	-
QT545BHN	335405	5 on 4 1/2	Black	-
QT655CHC	335420	6 on 5 1/2	Chrome	-
QT655BHN	335425	6 on 5 1/2	Black	-
QT765CHC	335430	8 on 6 1/2	Chrome	13/16"
QT765BHN	335435	8 on 6 1/2	Black	13/16"
QT865CHC	335440	8 on 6 1/2	Chrome	7/8"
QT865BHN	335445	8 on 6 1/2	Black	7/8"

TIRES & WHEELS

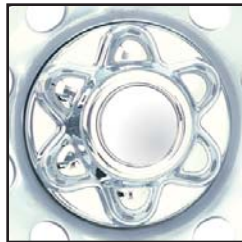

without hub covers

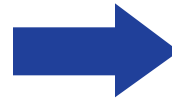

with QuickTrim® hub covers

### Center Caps

Many people want to add the “finishing touch” to their wheels. One sure way is to add a Center Cap. Available in chrome-plated steel or stainless steel. This unique design can be used with standard axles or with E-Z lube axles by simply removing a replacable plug.



Part No.	Ref. No.	Description	Finish	Wheel Center Pilot Size
CCP-60C	335650	ABS CENTER CAP PLUG ONLY	CHROME	N/A
295EZ	335750	CENTER CAP WITH PLUG	CHROME	2.95"
319EZ	336005	CENTER CAP WITH PLUG	CHROME	3.19"
319EZ-SS	336020	CENTER CAP WITH PLUG	STAINLESS STEEL	3.19"
330EZ	336170	CENTER CAP WITH PLUG	CHROME	3.30"
425EZ	336410	CENTER CAP WITH PLUG	CHROME	4.25"
425EZ-SS	336450	CENTER CAP WITH PLUG	STAINLESS STEEL	4.25"
482EZ	336750	CENTER CAP WITH PLUG	CHROME	4.82"
490EZ-SS	336815	CENTER CAP WITH PLUG	STAINLESS STEEL	4.90"
5125EZ	336825	CENTER CAP WITH PLUG	CHROME	5.125"
5125EZ-SS	336830	CENTER CAP WITH PLUG	STAINLESS STEEL	5.125"

### Chrome Nuts



These popular wheel nuts fit 1/2" or 9/16" diameter studs.

Part No.	Ref. No.	Description
12CLN	337000	1/2" CHROME BULGE STYLE WHEEL NUT WITH RIGHT HAND THREAD
916CLN	337020	9/16" CHROME ACORN WHEEL NUT WITH RIGHT HAND THREAD





## Chrome Hub Caps

Chrome Hub Caps have been an industry standard for many years. They are a fine choice to complement O.E.M. design wheels.

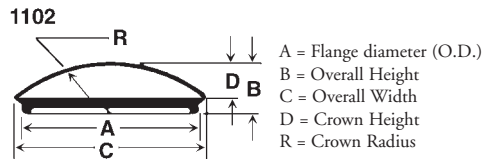
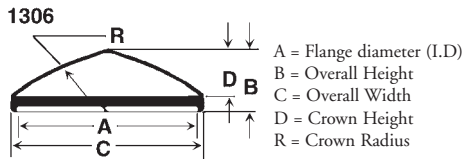

Part No.	Ref. No.	Wheel Size	A	B	C	D	R
1102	333700	8, 12, 13-4 Bolt	7.66	2.56	8.25	1.97	5.50
1302	333800	15", 5 on 4.5" Recon	8.74	2.41	9.03	1.60	7.13
1306	334000	15	10.20	3.05	10.62	2.37	CONE
1308	334600	13, 14, 15	9.23	2.62	9.62	1.87	7.00
1309	335000	16, 16.5	11.66	2.81	12.22	2.12	11.00

TIRES &  
WHEELS

## Valve Stems

Part No.	Ref. No.	Description
TR413	337200	VALVE STEM, (SMALL BASE - .453" HOLE) RUBBER SNAP-IN 65 PSI MAX
TR415	337400	VALVE STEM, (LARGE BASE - .625" HOLE) RUBBER SNAP-IN 65 PSI MAX
TR416	337600	VALVE STEM, METAL FOR PRESSURES EXCEEDING 65 PSI (.453" AND .625" HOLES)
501SW	337650	VALVE STEM, METAL, OUTER MOUNT, FOR ALUMINUM WHEELS WITH PRESSURES EXCEEDING 65 PSI (.453" AND .625" HOLES)
TR572	337700	VALVE STEM, METAL, 3 3/4" LONG-PRESSURE OVER 100 PSI (LARGE BASE - .625" HOLE)
TR600	337750	VALVE STEM, (SMALL BASE - .453" HOLE) METAL W/RUBBER SNAP-IN UP TO 100 PSI
TR801	337800	VALVE STEM, (LARGE BASE - .652" HOLE) METAL W/RUBBER SNAP-IN/UP TO 100 PSI

Every wheel needs a stem and we have the one you need. A metal valve stem is required when inflation pressure exceeds 60 PSI.



## Packaged Wheel Locks



Part No.	Ref. No.	Description
RG01-150	139980	1/2" WHEEL LOCK SET, INCLUDES 2 LOCKS & 1 KEY

## Slime Tire Sealant



Slime Super Duty Tire Sealant has been specially formulated for use in tubeless tires. Once installed into the tire, Slime will instantly seal punctures in the tread area up to 1/4".

- Non Aerosol
- Non Toxic
- Non Flammable
- Water Soluble
- Lasts up to 2 years

### HOW SLIME WORKS

Slime is a fiber based formula that remains liquid inside the tire. When a puncture happens, the escaping air forces Slime into the hole, where it forms a long lasting, flexible plug. Slime will not corrode rims or damage tires in any way.

Part No.	Ref. No.	Description
SDS-500/06	333200	SUPER DUTY SLIME TIRE SEALANT, 16 OZ.



TIRES & WHEELS

## Inches / Decimal / Metric Conversion Chart

This chart is provided for your convenience. With it you can easily convert fractions of an inch (in 1/64" increments) to decimals and metric equivalents.

Inches	Decimal	mm	Inches	Decimal	mm	Inches	Decimal	mm
1/64	0.015	0.396	11/32	0.343	8.731	43/64	0.671	17.065
1/32	0.031	0.793	23/64	0.359	9.123	11/16	0.687	17.462
3/64	0.046	1.190	3/8	0.375	9.525	45/64	0.703	17.859
1/16	0.062	1.587	25/64	0.390	9.921	23/32	0.718	18.256
5/64	0.078	1.984	13/32	0.406	10.318	47/64	0.734	18.653
3/32	0.093	2.381	27/64	0.421	10.715	3/4	0.750	19.050
7/64	0.109	2.778	7/16	0.437	11.112	49/64	0.765	19.446
1/8	0.125	3.175	29/64	0.453	11.509	25/32	0.781	19.843
9/64	0.140	3.571	15/32	0.468	11.906	51/64	0.796	20.240
5/32	0.156	3.968	31/64	0.484	12.303	13/16	0.812	20.637
11/64	0.171	4.365	1/2	0.500	12.700	53/64	0.828	21.034
3/16	0.187	4.762	33/64	0.515	13.096	27/32	0.843	21.431
13/64	0.203	5.159	17/32	0.531	13.493	55/64	0.859	21.828
7/32	0.218	5.556	35/64	0.546	13.890	7/8	0.875	22.225
15/64	0.234	5.953	9/16	0.562	14.287	57/64	0.890	22.621
1/4	0.250	6.350	37/64	0.578	14.684	29/32	0.906	23.018
17/64	0.265	6.746	19/32	0.593	15.081	59/64	0.921	23.415
9/32	0.281	7.143	39/64	0.609	15.478	15/16	0.937	23.812
19/64	0.296	7.540	5/8	0.625	15.875	61/64	0.953	24.209
5/16	0.312	7.937	41/64	0.640	16.271	31/32	0.968	24.606
21/64	0.328	8.334	21/32	0.656	16.668	63/64	0.984	25.003



We make it a point to have a wide selection of top quality trailer parts available to our customers. Regardless of the type of trailer you build or repair, we have something to fit your needs.

## Jacks, Couplers and Winches

Fulton Coupler Handle	F-2	Sidewind Swivel, Snap Ring Mount Jacks	F-12
Straight Tongue Couplers	F-2	R.V. Landing Gear	F-13
A-Frame Couplers	F-3	Stabilizer Jack	F-13
Adjustable Tongue Couplers	F-4	EZ Jack	F-13
“Yard Dog” Couplers	F-4	Leveling Scissor Jack	F-13
Gooseneck Couplers	F-5	Power Jack	F-13
Coupler Latch Repair Kits	F-5	Dropleg Jacks	F-14
Locks & Lock Brackets	F-7	Landing Gear	F-16
Combination Pintle Hitch	F-8	Dropleg Jack Accessories	F-16
Duplex Hitch	F-8	Swivel Jack Mounting Brackets	F-17
Pintle Hooks	F-8	A-Frame Jack Support Plates and Flanges	F-17
Flat Nose Coupler	F-9	Jack Feet and Casters	F-17
Draw Bars	F-9	Jack / Coupler Repair Parts	F-18
Nose Plates	F-9	Agricultural / Industrial Winches	F-19
Rack Posts and Gearboxes	F-10	Single Speed Winches	F-19
Topwind & Sidewind A-Frame Jacks	F-10	Ramsey Electric Winches	F-20
Topwind & Sidewind Swivel,		Two Speed Winches	F-20
Snap Ring Mount Jacks	F-11	Winch Strap	F-20
Fulton Trailer Stand	F-12		

### Atwood Straight Tongue Couplers



80050

Atwood's 2" ball couplers feature a patented high strength wrap around yoke with a sliding clamp for secure coupling. #80131 features self-adjusting ball clamp which automatically adjusts to slight variations in ball size.

Part No.	Ref. No.	Ball	Tongue Size	Finish	Capacity	Class
80050	268000	2"	3" Square	Painted	3,500 lb	2
80060	268100	2"	3" Square	Painted	5,000 lb	3
80081	268400	2"	2" Square	Painted	5,000 lb	3
80131	268800	2 5/16"	3" Square	Painted	8,500 lb	4

### Shelby Straight Tongue Couplers



5144

Shelby's "Posi-Lock" trigger action mechanism clamps and releases the ball for fast, easy and secure hookups.

Part No.	Ref. No.	Ball	Tongue Size	Finish	Capacity	Class
5143	262700	1 7/8"	2" Square	Oily	2,000 lb	1
5141	262710	1 7/8"	2 1/2" Square	Oily	2,000 lb	1
5144	262720	1 7/8"	3" Square	Oily	2,000 lb	1
5145	262730	2"	2" Square	Oily	3,500 lb	2
5142	262740	2"	2 1/2" Square	Oily	3,500 lb	2
5146	262750	2"	3" Square	Oily	3,500 lb	2
5175	262775	2"	3" Square	Oily	5,000 lb	3

### Redline Straight Tongue Couplers



CP01-020

Zinc plated straight tongue couplers are ideal for marine, utility and cargo applications. Redline couplers are labeled, making them ideal for retail display.

Part No.	Ref. No.	Ball	Tongue Size	Finish	Capacity
CP01-010	264002	1 7/8"	2" Square	Zinc Plated w/ label	2,000 lbs
CP01-020	264004	1 7/8"	2 1/2" Square	Zinc Plated w/ label	2,000 lbs
CP01-030	264006	1 7/8"	3" Square	Zinc Plated w/ label	2,000 lbs
CP01-040	264010	2"	2" Square	Zinc Plated w/ label	3,000 lbs
CP01-050	264012	2"	2 1/2" Square	Zinc Plated w/ label	3,000 lbs
CP01-060	264014	2"	3" Square	Zinc Plated w/ label	3,000 lbs
CP01-070	264020	2"	3" Square	Zinc Plated w/ label	5,000 lbs

### Fulton Straight Tongue Couplers



11250

Fulton's FAS-LOK locking lever hooks up quick and easy to the towing vehicle. The #308 handwheel style is widely used in the rental industry.

Part No.	Ref. No.	Ball	Tongue Size	Finish	Capacity	Class
11200	265505	1 7/8"	2" Square	Oily	2,000 lb	1
11250	265507	1 7/8"	2 1/2" Square	Oily	2,000 lb	1
11300	265509	1 7/8"	3" Square	Oily	2,000 lb	1
22200	265515	2"	2" Square	Oily	3,500 lb	2
22250	265517	2"	2 1/2" Square	Oily	3,500 lb	2
22300	265519	2"	3" Square	Oily	3,500 lb	2
308	267000	2" or 2 1/8"	2 7/8" Square	Painted	5,000 lb	3

### HammerBlow Straight Tongue Couplers



2B2

HammerBlow's drop-forged couplers offer spring-loaded collars which provide positive-action coupling, ensuring a snug fit onto the hitch ball.

Part No.	Ref. No.	Ball	Tongue Size	Finish	Capacity
2B2	279400	2"	2 1/4" O.D. Round Shank	Painted	5,000 lb
2B4	279600	2"	3" Square	Painted	5,000 lb
2B5	279800	2"	3 1/2" Round	Painted	5,000 lb
3B4	280100	2"	3" Square	Painted	7,000 lb
4B2	280200	2 5/16"	2 1/4" O.D. Round Shank	Painted	12,500 lb
4B4	280400	2 5/16"	3" Square	Painted	12,500 lb



Fulton's coupler handle fits most 1 7/8" and 2" couplers. It has a non-corrosive zinc finish and an easy bolt on installation.



Part No.	Ref. No.	Description
CH0201	267100	Coupler Handle with Grip, Zinc

### Atwood A-Frame Couplers

Atwood's A-Frame Couplers are available with their patented wraparound yoke style (A), a thumb latch style (B), or with a trigger style (C) locking mechanism. The #82680 undermount coupler, which has a thumb latch style locking mechanism, is widely used in the mobile home industry.



Part No.	Ref. No.	Ball	Style	Tongue Size	Finish	Capacity	Class	
80071	268200	2"	A	50° A-Frame	Painted	5,000 lb	3	
88555	268250	2"	C	50° A-Frame	Painted	8,000 lb	4	
80101	268600	2 5/16"	A	50° A-Frame	Painted	8,500 lb	4	
81911	269000	2 5/16"	B	50° A-Frame	Painted	10,000 lb	4	
82680	269200	2 5/16"	Not Shown	50° A-Frame Undermount	Painted	13,000 lb	4	
64-4102	289450	2 5/16"	"Franklin"	50° A-Frame	Painted	10,000 lb	4	
88050	267840	2"	Latch Repair Kit for Franklin 64-4103					
88060	267850	2 5/16"	Latch Repair Kit for Franklin 64-4102					

80071  
Style A



81911  
Style B



88555  
Style C



### Shelby A-Frame Couplers

Shelby's "Posi-Lock" trigger action mechanism clamps and releases the ball for fast, easy and secure hookups.



Part No.	Ref. No.	Ball	Tongue Size	Finish	Capacity	Class
5172	262800	2"	50° A-Frame	Oily	5,000 lb	3
5104	262810	2 5/16"	50° A-Frame	Painted	10,000 lb	4

5172



JACKS,  
COUPLERS &  
WINCHES

### Fulton A-Frame Couplers

Fulton's new patented design "Wedge-Latch" is featured on part #44305R, along with a replaceable latch and ball clamp mechanism. Part #33305 is a fabricated coupler featuring the FAS-LOK locking lever for quick and easy hook up.



Part No.	Ref. No.	Ball	Tongue Size	Finish	Capacity	Class
33305	265523	2"	50° A-Frame	Oily	5,000 lb	3
44305R	265535	2 5/16"	50° A-Frame	Oily	10,000 lb	4



44305R

### HammerBlow A-Frame Couplers

HammerBlow's drop-forged couplers offer spring-loaded locking collars which provide positive-action coupling, ensuring a snug fit onto the hitch ball.

Part No.	Ref. No.	Ball	Tongue Size	Finish	Capacity
2B8	280000	2"	50° A-Frame	Painted	5,000 lb
3B8	280120	2"	50° A-Frame	Painted	7,000 lb
4B8L	280590	2 5/16"	50° A-Frame	Painted	12,500 lb



3B8



## “Yard Dog” Couplers

### Keep Your Equipment Safe – Protect It With A "Yard Dog"!

As tough as it's name, the "Yard Dog" Coupler design has been popular in the Rental Industry for many years. The forged/cast coupler housing is virtually indestructible.

Features include:

- Weld-on/bolt-on coupler.
- Adjustable Height Couplers:
  - 1 7/8" or 2" ball
  - 2 5/16" ball
  - Standard or extra long channel bracket
- Ring-To-Coupler Adapter



WFH3



WFAH4-AXL

Part No.	Ref. No.	Ball	Description	Capacity
WFH3	267300	1 7/8" & 2"	Weld-on or Bolt-on straight tongue mounting	7,500 lb
WFAH3	267305	1 7/8" & 2"	Adjustable coupler only, less channel bracket	7,500 lb
WFAH3-A	267310	1 7/8" & 2"	Adjustable coupler assembly, w/ 4 hole bracket and bolts	7,500 lb
WFAH3-AXL	267315	1 7/8" & 2"	Adjustable coupler assembly, w/ 6 hole bracket and bolts	7,500 lb
WFAH4	267320	2 5/16"	Adjustable coupler only, less channel bracket	12,000 lb
WFAH4-A	267325	2 5/16"	Adjustable coupler assembly, w/ 4 hole bracket and bolts	12,000 lb
WFAH4-AXL	267330	2 5/16"	Adjustable coupler assembly, w/ 6 hole bracket and bolts	12,000 lb
WFH3LA	267335	1 7/8" & 2"	Ring to ball coupler adapter, fits 2 1/2" I.D. Eye	3,500 lb
WFH3RK	267345	1 7/8" & 2"	Latch repair kit for WFH3, WFAH3	

JACKS,  
COUPLERS &  
WINCHES

## Adjustable Tongue Couplers

Available in 4" or 8" height adjustment, each assembly includes a weld-on channel bracket, and 2 bolts & nuts for mounting. #34H Hitch Pins for the Clevis type couplers are sold separately (see page G-8).



18128



23309



9095



4B6M

Part No.	Ref. No.	Coupler Type	Description	Capacity
18128	305600	3" eye	Coupler, w/ 4 hole bracket and bolts	12,000 lb
18128XL	305650	3" eye	Coupler, w/ 6 hole bracket and bolts	12,000 lb
9095	305700	3/4" clevis	Coupler, w/ 4 hole bracket and bolts	12,000 lb
9095XL	305750	3/4" clevis	Coupler, w/ 6 hole bracket and bolts	12,000 lb
23309	305800	2 5/16" ball	Coupler, w/ 4 hole bracket and bolts	12,000 lb
23309XL	305805	2 5/16" ball	Coupler, w/ 6 hole bracket and bolts	12,000 lb
1040	305806	2" ball	H-Blow Coupler, w/ 4 hole bracket and bolts	7,000 lb
1040XL	305807	2" ball	H-Blow Coupler, w/ 6 hole bracket and bolts	7,000 lb
1051	305808	2 5/16" ball	H-Blow Coupler, w/ 4 hole bracket and bolts	12,500 lb
1051XL	305809	2 5/16" ball	H-Blow Coupler, w/ 6 hole bracket and bolts	12,500 lb
16137	305810	3" eye	Eye only for 18128, 18128XL	
8979	305815	3/4" clevis	Clevis only for 9095, 9095XL	
18820	305820	2 5/16" ball	Coupler only for 23309, 23309XL	
3B6M	305824	2" ball	H-Blow Coupler, w/ bolts for 1040, 1040XL	7,000 lb
4B6M	305826	2 5/16" ball	H-Blow Coupler, w/ bolts for 1051, 1051XL	12,500 lb
9093	305830		5/8" x 4 1/2" Mounting Bolt	
6-38	078800		5/8" Locknut for 9093	
8978	306000		4 - hole channel bracket only	
8978XL	306025		6 - hole channel bracket only	

## Redline Packaged Coupler Latch Repair Kits

Trailer towing with a worn or broken coupler is dangerous. Worn or broken couplers should be replaced or repaired. Redline Kits are packaged for showroom display.



Part No.	Ref. No.	Manufacturer	Coupler Style	Ball
CP02-010	264050	Atwood	Yoke Style	2"
CP02-020	264055	Atwood	80131	2 5/16"
CP02-030	264060	Atwood	Trigger style A-Frame	2"
CP02-040	264070	Shelby	Posi-Lock, Class 1	1 7/8"
CP02-050	264075	Shelby	Posi-Lock, Class 2	2"
CP02-060	264080	Shelby	Posi-Lock, Class 3	2"
CP02-090	264100	Fulton	Handwheel (308)	2"
CP02-110	264120	Hammerblow	High profile handle	All
CP02-120	264125	Hammerblow	Low profile handle	All



## Superior Gooseneck Couplers

A leader in the industry! Superior features a cast cone shaped bottom plate and a heavy-duty cast handle. Available in round or square tube design, both adjustable and nonadjustable.

Part No.	Ref. No.	Ball	Tube O.D.	Overall Height	Extended Height	Capacity	
ST2516NP	291200	2 5/16"	Coupler Only, No Pipe			20,000 lbs	
ST251632	292200	2 5/16"	4 1/2" Round	32"	Non-adjustable	20,000 lbs	
SAC2516	293000	2 5/16"	4 1/2" Round	28"	38"	20,000 lbs	
SAC2516-LP	293025	2 5/16"	4 1/2" Round	30"	42"	20,000 lbs	
GG2516ADJ	293100	2 5/16"	4 1/2" Round	30"	38"	30,000 lbs	
SQ2516ADJ	293200	2 5/16"	4 1/2" Square	32"	40"	20,000 lbs	
SAC2516-IP	293800	2 5/16"	4" Round	Replacement Inner Assembly for #SAC 2516		20,000 lbs	
SAC-BOLT	293900	Replacement 3/4"-10 x 3" Set Screw for #SAC2516					
SAC-NUT	293910	Replacement 3/4" Nut for #SAC2516					



JACKS,  
COUPLERS &  
WINCHES

## HammerBlow Gooseneck Couplers

HammerBlow has a fabricated cone shaped bottom plate. The #HBQ2516ADJ features a user-friendly cam lock height adjustment design allowing hands free modifications.

Part No.	Ref. No.	Ball	Tube O.D.	Overall Height	Extended Height	Capacity
HB2516NP	291250	2 5/16"	Coupler Only, No Pipe			20,000 lbs
HBA2516	293050	2 5/16"	4 1/2" Round	29 1/2"	40 1/2"	20,000 lbs.
HBQ2516ADJ	293150	2 5/16"	4 1/2" Square	31 3/4"	42 1/2"	20,000 lbs.



HBQ2516ADJ



## Trailer Equipment Mfg. Gooseneck Couplers



LL2516ST SH2516SRD



SM2516NP

T.E.M.'s "AutoLock" design works with the same principle as a 5th wheel. The jaws of the coupler open and unhook from the hitch ball without having to raise or lower the coupler. Their non-autolock couplers, SH and BH series, feature a wider and deeper cast cone-shaped bottom plate for easier line-up of coupler and ball. SH series is made with a stamped steel top plate, while the BH series offers greater capacity utilizing a forged steel one-piece top plate.

### AutoLock Couplers

Part No.	Ref. No.	Ball	Tube O.D.	Overall Height	Extended Height	Capacity
SM2516NP	291400	2 5/16"		Coupler Only, No Pipe		24,000 lbs
SM300NP	292000	3"		Coupler Only, No Pipe		30,000 lbs.
SM251628	292400	2 5/16"	4" Round	28"	Non-adjustable	24,000 lbs
SM30028	292800	3"	4 1/2" Round	28"	Non-adjustable	30,000 lbs.
LL2516ST	293400	2 5/16"	4" Square	28"	38"	24,000 lbs
J2516	267870	2 5/16"	Latch repair kit for SM2516, FB2516			

### Non-AutoLock Couplers

Part No.	Ref. No.	Ball	Tube O.D.	Overall Height	Extended Height	Capacity
SH2516SRD	293060	2 5/16"	4 1/2" Round	28"	38"	20,000 lbs.
BH2516SRD	293110	2 5/16"	4 1/2" Round	28"	38"	30,000 lbs.

JACKS,  
COUPLERS &  
WINCHES

## Fulton Gooseneck Coupler



Fulton's Gooseneck Coupler has four set screws, 14 1/2" of adjustability and a 24,000 lb. capacity. The lever design offers quick and easy latching and unlatching action. Finish is prime paint.



GNT24

Part No.	Ref. No.	Ball	Tube O.D.	Overall Height	Extended Height	Capacity
GN24	291000	2 5/16"		Coupler Only, No Pipe		24,000 lbs.
GNT24	292410	2 5/16"	4 1/2" Round	24"	38 1/2"	24,000 lbs.
1542S01	267860	2 5/16"	Latch repair kit for GN24, GNT24			

## Gooseneck Coupler Head

Can be mounted on the trailer as a standard gooseneck coupler or in the truck bed. Removable steel pin secures hitch ball in the cast housing.



K1

Part No.	Ref. No.	Ball	Description	Capacity
K1	291300	2 5/16"	Coupler Only, No Pipe	20,000 lbs
K2	291900	3"	Coupler Only, No Pipe	N/A
12SL	293920		Replacement Pin for K1 Coupler	
34SL	293925		Replacement Pin for K2 Coupler	



## Locks & Lock Brackets

Protect your investment! To aid in the prevention of trailer theft, we have a lock to fit most popular styles of couplers on the market today.

### MasterLock

**Master Lock.** All MasterLock products resist corrosion.

Part No.	Ref. No.	Ball	Description
35	290200	2" & 2 5/16"	Fits most Marvel couplers
36	290400	2" & 2 5/16"	Fits 2" Hadco & 2 5/16" Atwood coupler
377DAT	290590	1 7/8" & 2"	Fits most fabricated couplers
39	290600	1 7/8" & 2"	Fits HammerBlow Bulldog couplers
37D	290755	-	Padlock w/ 9/16" or 1/2" shackle shielded
40D	290760	-	Padlock w/ 3/8" shackle shielded
40KA	290765	-	Padlock w/ 3/8" shackle, keyed alike
605DAT	290790	-	Padlock w/ 1/4" shackle, brass



36



39



37D



605DAT



40D, 40KA



377DAT

### Fulton Performance Products



Heavy duty cast construction with attractive color coating.

Part No.	Ref. No.	Ball	Description
TP20	290050	2"	Gorilla Guard Fits Most Fabricated Couplers
TP25	290450	2 5/16"	Gorilla Guard Fits Most Fabricated Couplers
TK100	290900	-	"Trailer Keeper" Wheel Lock, up to 15" wheels



TK100



TP20

JACKS,  
COUPLERS &  
WINCHES

### EZ Lock Brackets

Precision made of aircraft aluminum, the EZ Lock Brackets will not rust and are highly visible to discourage would-be thieves. Easy to install. Simply place bracket over the coupler, insert the pin and attach padlock.

Part No.	Ref. No.	Ball	Description
EZTL33	290510	1 7/8", 2" & 2 5/16"	Fits most fabricated couplers
EZTL33-40D	290515	1 7/8", 2" & 2 5/16"	EZTL33 and one padlock
EZHB2	290700	2" & 2 5/16"	Fits HammerBlow Bulldog Couplers
EZHB2-40D	290705	2" & 2 5/16"	EZHB2 and one padlock
EZTL50	290850	2 5/16" & 3"	Fits most gooseneck couplers
EZTL51	290856	-	Fits Gooseneck setscrew
EZTL50-40D	290855	2 5/16"	EZTL50 and one padlock
EZTL5051-40KA	290858	2 5/16"	EZTL50, EZTL51 & two keyed alike padlocks
EZTL60	290860	-	Fits most tow ring draw bars
EZTL60-40D	290865	-	EZTL60 and one padlock
EZTL70	290870	-	Fits most 2" King pins
EZTL70-40D	290875	-	EZTL70 and one padlock



EZTL60



EZTL70

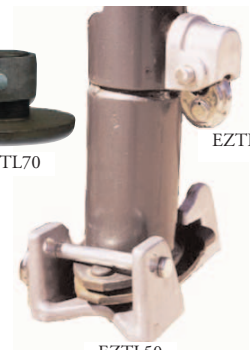

EZTL50

### Misc. Coupler Locks

Part No.	Ref. No.	Ball	Description
CL-3	290100	2"	Fits all Atwood 2" yoke style couplers
HL00101	290800	1 7/8" & 2"	Fits most trigger style couplers



CL-3



HL00101

## Pintle Hooks



Popular in construction and industry, the following Pintle Hooks can be used when towing light to medium weight trailers. Available in 4 or 6 bolt mounting patterns, with or without spring cushion.

Part No.	Ref. No.	Description	Mounting Holes	Max. wt. Tongue	Gross wt. Trailer
T60AL	306400	Rigid type, Holland	4	2,000	10,000
R5T	306401	Rigid type, Wallace	4	2,000	10,000
T60AOL-8	306600	Rigid type, Holland	4	6,000	30,000
R15T	306601	Rigid type, Wallace	4	6,000	30,000
T100A	306800	Swivel w/ spring cushion, Holland	6	4,000	20,000
S15T	306801	Swivel w/ spring cushion, Wallace	6	4,000	30,000

## Holland Cushioned Pintle Hooks



For use on over-the-road and heavy equipment trucks. Available in 4 or 10 bolt mounting patterns, with or without air cushion.

Part No.	Ref. No.	Description	Mounting Holes	Max. Wt. Tongue	Gross Wt. Trailer
PH200	307000	Rigid type w/ air cushion	4	18,000	90,000
PH200-1	307200	Rigid type w/o air cushion	4	18,000	90,000
PH400	307400	Rigid type w/ air cushion	10	18,000	90,000
PH400-1	307600	Rigid type w/o air cushion	10	18,000	90,000

## Redline Combination Pintle Hitch



Redline combination pintle hitches are ideal for Farm, Construction and general use. Packaged for showroom display, Redline pintle hitch includes all necessary mounting hardware. Imported.

Part No.	Ref. No.	Ball	Max. Wt. Tongue	Ball Capacity	Pintle Capacity
CPH-2000	306104	2"	500	5,000	12,000
CPH-2516	306105	2 5/16"	800	8,000	12,000

## Wallace Forge Combination Pintle Hooks



Drop-forged Combination Pintle Hooks/Ball Hitch include a chrome ball. Hitch balls are interchangeable.

Part No.	Ref. No.	Ball	Mounting Holes	Max. Wt. Tongue	Ball Capacity	Pintle Capacity
DPH2000	306110	2"	4	3,000	10,000	16,000
DPH2516	306120	2 5/16"	4	3,000	10,000	16,000
178DPRB	306130	1 7/8"	Replacement ball for DPH series		6,000	8,000
2000DPRB	306145	2"	Replacement ball for DPH series		10,000	16,000
2516DPRB	306155	2 5/16"	Replacement ball for DPH series		10,000	16,000

## Holland Duplex Hitch



This Pintle Hook/2" Ball Hitch is well suited for use in the utility, construction and rental industries. The Pintle Hook and 2" Ball are part of a **single durable steel casting**, which eliminates the possibility of the ball coming loose.

Part No.	Ref. No.	Ball	Mounting Holes	Max. Wt. Tongue	Ball Capacity	Pintle Capacity
PH16-B	306200	2"	4	3,000	10,000	19,000

## Square Mount Draw Bars and Nose Plates

Commonly used on equipment and over-the-road trailers, the flat back design of the following Draw Bars allows easy mounting on the nose plate.

Square Mount Draw Bars					
Part No.	Ref. No.	Type	Eye Diameter	GTW lbs.	Bolt Pattern
1250-15	308400	Holland	2 1/2"	35,000	4 Bolt, 6" Square
R49A	308401	Wallace	2 1/2"	42,000	4 Bolt, 6" Square
1385	308600	Holland	3"	60,000	4 Bolt, 6" Square
R51A	308601	Wallace	3"	66,000	4 Bolt, 6" Square

Nose Plates			
Part No.	Ref. No.	Description	For Use with:
TNP71675	308410	8 hole, 3/4" x 7" x 16"	R49A & 1250-15
TNP716100	308610	8 hole, 1" x 7" x 16"	R51A & 1385



1250-15



TNP71675

## Atwood Flat Nose Coupler

The flat nose coupler is an excellent alternative to tow rings or pintle hooks. This pull type coupler works with a 2 5/16" hitch ball.



Part No.	Ref. No.	Ball	Tongue Size	Finish	Capacity	Class
75074	269350	2 5/16"	Flat Nose	Painted	25,000 lb	4

JACKS,  
COUPLERS &  
WINCHES

## Tow Ring Draw Bars

Primarily used on equipment and utility trailers, the single point mounting design eliminates the need for a swivel type pintle hook in demanding off-road situations.

Part No.	Ref. No.	Type	Eye Diameter	GTW lbs.	Shank Dimension
1250-3	307800	Holland	2 1/2"	15,000	1 1/2" O.D. x 3 1/4"L
050A	307801	Wallace	2 1/2"	20,000	1 1/2" O.D. x 3 1/4"L
1249-2H	308000	Holland	3"	45,000	2" O.D. x 4 1/2"L
051B	308001	Wallace	3"	50,000	2" O.D. x 3 3/4"L
1249-49	308200	Holland	3"	45,000	2" O.D. x 8 1/2"L



## Flat Draw Bars

The Flat Bar design allows the following Draw Bars to easily bolt to the trailer tongue (#LW10 welds to trailer tongue). For all types of trailer applications.

Part No.	Ref. No.	Type	Eye Diameter	GTW lbs.	Shank Dimensions
LW10	308300	Wallace	2 1/2"	10,000	2 1/2" wide, 2" long
1228-1	308800	Holland	2 7/16"	20,000	7 Bolt, 3" x 14 1/4"
043D	308801	Wallace	2 1/2"	20,000	7 Bolt, 3" x 14 1/4"
1238	309000	Holland	3"	22,000	7 Bolt, 3" x 13 5/8"
052D	309001	Wallace	3"	22,000	7 Bolt, 3" x 14 5/8"



### Atwood Topwind & Sidewind A-Frame Jacks



For mounting on A-Frame Couplers, the following Jacks come with or without a mounting bracket, for bolt-on or weld-on applications.

Part No.	Ref. No.	Capacity	Lift	Bracket Height	Retracted Height	Type of Wind
80036	272200	1,000 LBS	12"	NO BRACKET	19"	TOP
80167	272400	1,000 LBS	15"	NO BRACKET	20.5"	TOP
80009	272800	1,000 LBS	15"	7.75"	22"	TOP
80000	273000	1,000 LBS	14"	7.75"	24.25"	SIDE
80401	273200	2,000 LBS	14"	8.75"	22"	TOP
87510	273400	2,000 LBS	14"	7.75"	24.25"	SIDE
80380	273600	5,000 LBS	14"	NO BRACKET	21.75"	TOP
80391	273800	5,000 LBS	14"	11.25"	22"	TOP

### Fulton Topwind & Sidewind A-Frame Jacks



For mounting on A-Frame Couplers, the following Jacks come with a mounting bracket, rolled Acme threads and anti-friction thrust bearings, powder coat painted inner and outer tubes. For bolt-on or weld-on applications.

Part No.	Ref. No.	Capacity	Lift	Bracket Height	Retracted Height	Type of Wind
JA104T	267250	1,000 LBS	14"	6"	20"	TOP
JA214T	267260	2,000 LBS	14"	7"	19"	TOP
JA214S	267258	2,000 LBS	14"	7"	21"	SIDE
JA514T	267262	5,000 LBS	14"	9"	19"	TOP

JACKS,  
COUPLERS &  
WINCHES

### HammerBlow Topwind A-Frame Jacks



For mounting on A-Frame Couplers, the following Jacks come with a mounting bracket for bolt-on or weld-on applications. The #155033CW comes with a removable steel wheel.

Part No.	Ref. No.	Capacity	Lift	Bracket	Retracted Height	Type of Wind
155022	282625	2,000 LBS	15"	8.5"	24.25"	TOP
155033	282630	2,000 LBS	15"	5.5"	23.25"	TOP
155033CW	282635	1,000 LBS	15"	12.50"	30.50"	TOP
155100	282700	2,000 LBS	15"	7.5"	28.25"	TOP
175020	284800	5,000 LBS	15"	10.7"	26.45"	TOP

### HammerBlow Rack Posts and Gearboxes



Hammerblow's ever-popular Rack Jacks are available in many mounting and foot options. Choose the gearbox and rack post best suited for your particular need.

Part No.	Ref. No.	Description	Type	Capacity
161	280800	GEAR BOX	WELD-ON "L"	750 LB
165	281200	GEAR BOX	A-FRAME	750 LB
167	281400	GEAR BOX	WELD-ON PIPE	750 LB
169	281600	GEAR BOX	BOLT-ON	750 LB
018006	281800	RACK POST	STEEL WHEEL	750 LB
018007	282000	RACK POST	POLY WHEEL	750 LB
018520	282200	RACK POST	SAND FOOT	750 LB

### Atwood Topwind & Sidewind Swivel, Pipe Mount Jacks

For industrial and agricultural applications. Pipe Mount Swivel Jacks are engineered for the most demanding situations giving superior side-load stability over snap ring jacks.

The inner Weld-on Swivel Bracket that attaches to the trailer is sold separately on page F-17.

Part No.	Ref. No.	Capacity	Lift	Bracket Height	Retracted Height	Type of Wind
80459	271000	2,000 LBS	10"	10.4"	14.2"	TOP
82332	271200	2,000 LBS	10"	10.7"	15.5"	SIDE
81264	271400	2,000 LBS	15"	7.8"	22.1"	TOP
82471	271600	5,000 LBS	15"	10.6"	25.1"	TOP



### HammerBlow Topwind & Sidewind Swivel, Pipe Mount Jacks

For industrial and agricultural applications, the following Pipe Mount Jacks come complete with the inner weld-on swivel bracket that attaches to the trailer.

Part No.	Ref. No.	Capacity	Lift	Bracket Height	Retracted Height	Type of Wind
158451	282800	2,000 LBS	10"	11.25"	18.5"	TOP
158109	283000	2,000 LBS	10"	11.25"	17"	SIDE
158452	283200	2,000 LBS	15"	14.5"	27.75"	TOP
158151	283400	2,000 LBS	15"	14.5"	26.5"	SIDE
178101	284000	5,000 LBS	10"	11.25"	18.5"	TOP
178201	284200	5,000 LBS	10"	10"	17.5"	SIDE
178151	284400	5,000 LBS	15"	14.5"	27.75"	TOP
178203	284600	5,000 LBS	15"	15"	21.75"	SIDE
198100	285200	7,000 LBS	10"	10"	18.5"	TOP
198150	285400	7,000 LBS	10"	10"	17"	SIDE
198200	285600	7,000 LBS	15"	15"	20"	TOP
198250	285800	7,000 LBS	15"	15"	22"	SIDE



JACKS,  
COUPLERS &  
WINCHES

### Fulton Topwind & Sidewind Square Type, Pipe Mount Jacks

The square tube design offers increased side load strength. The #35TG15F and #35SG15F have a **standard round pipe mount**. The #35TQ15F and #35SQ15F have a **square pipe mount** for superior support of the jack, transferring the stress of the load from the 5/8" pin to the four corners of the bracket. The following Pipe Mount Jacks come complete with the inner weld-on mounting bracket that attaches to the trailer.

Part No.	Ref. No.	Capacity	Lift	Bracket Height	Retracted Height	Type of Wind
35SG15F	267268	3,500 LBS	15"	15"	20"	SIDE
35SQ15F	267269	3,500 LBS	15"	15"	20"	SIDE
35TG15F	267266	5,000 LBS	15"	15"	20"	TOP
35TQ15F	267267	5,000 LBS	15"	15"	20"	TOP



### Atwood Topwind & Sidewind Swivel, Snap Ring Mount Jacks

Snap Ring Jacks swing either direction to a position parallel with the tongue. The spring loaded single-lock pin secures the jack in an up or down position. The #80302 and #87535 have a wheel attached for easy movement of the trailer when not connected to the tow vehicle. The Swivel Mount Brackets that attach to the trailer are sold separately on page F-17.

Part No.	Ref. No.	Capacity	Lift	Bracket Height	Retracted Height	Type of Wind	Type of Foot
87535	269600	500 LBS	10"	12.75"	22.25"	SIDE	WHEEL
80302	269400	500 LBS	8"	13"	19"	TOP	WHEEL
80273	269800	1,000 LBS	10"	11.5"	15"	TOP	SAND
80294	270200	1,000 LBS	15"	15"	21"	TOP	SAND
80452	270000	2,000 LBS	10"	11.5"	15"	TOP	SAND



### Shelby Snap Ring Swivel Jacks



5754

Shelby's Snap Ring Jacks feature a ball bearing thrust support for easier cranking and "Zinc Supersealer" to fight corrosion. Jacks come complete with a bolt-on bracket (for up to 3" x 5" tongue) or a weld-on bracket.

Part No.	Ref No.	Capacity	Lift	Bracket Type	Bracket Height	Retracted Height	Type of Wind	Type of Foot
5754	263000	850 LBS	10"	BOLT-ON	15 3/8"	23"	SIDE	WHEEL
5756	263100	850 LBS	10"	WELD-ON	14 7/8"	23"	SIDE	WHEEL

### Redline Snap Ring Swivel Jack



The Redline replacement jack features a zinc plated finish for corrosion resistance and easy bolt-on design. The snap ring swivel jack is boxed for convenience and showroom display. Poly caster included.

Part No.	Ref. No.	Capacity	Lift	Bracket Type	Bracket Height	Retracted Height	Type of Wind	Type of Foot
JP01-020	264200	750 lbs	10"	BOLT-ON	15 3/8"	23"	SIDE	WHEEL

### Fulton Swivel Jacks



Fulton's Swivel Jacks are zinc plated and very popular for today's marine trailers. Jacks come complete with a bolt-on bracket (for up to 3" x 5" tongue) or a weld-on bracket. The XP10 and XP10W feature a Bolt-Through Swivel, which produces less deflection under load and during operation. TJ503 and TJ507 utilize a Snap Ring Swivel.

JACKS,  
COUPLERS &  
WINCHES



TJ503

Part No.	Ref. No.	Capacity	Lift	Bracket Type	Bracket Height	Retracted Height	Type of Wind	Type of Foot
TJ503	267280	800 lbs	10"	BOLT-ON	15.3"	22.8"	SIDE	WHEEL
XP10	267281	1000 lbs	10"	BOLT-ON	15"	23.5"	SIDE	WHEEL
TJ507	267282	800 lbs	10"	WELD-ON	15.3"	22.8"	SIDE	WHEEL
XP10W	267283	1000 lbs	10"	WELD-ON	15"	23.5"	SIDE	WHEEL

### Fulton Trailer Stand



The compact design of Fulton's trailer stand is ideal for light duty trailers. It mounts underneath a 3" x 3" trailer tongue, acting as a kick stand and can pivot and lock parallel to the tongue. Zinc plated with mounting hardware included.



Part No.	Ref No.	Capacity	Bracket Type	Ground Clearance	Type of Wind	Type of Foot
TS300	267288	300 LBS	BOLT-ON	15"	N/A	WHEEL

### HammerBlow Snap Ring Swivel Jacks



151401



The HammerBlow Snap Ring Jacks come complete with a bolt-on bracket (for up to 3" x 5" tongue) or a weld-on bracket.

Part No.	Ref. No.	Capacity	Lift	Bracket Height	Retracted Height	Type of Wind	Type of Foot
159204	283425	1,000 LBS	10"	14.75"	22.75"	SIDE	WHEEL
151401	282400	2,000 LBS	10"	11.25"	18.5"	TOP	SAND
151101	282600	2,000 LBS	10"	11.25"	17.5"	SIDE	SAND
151421	282425	2,000 LBS	15"	14.5"	27.75"	TOP	SAND
171401	283800	5,000 LBS	10"	11.25"	18.5"	TOP	SAND
171412	283825	5,000 LBS	15"	14.5"	27.75"	TOP	SAND

### Atwood Power Jack

Atwood's Power Jack allows hassle-free trailer lifting with a 12VDC electric motor. Suitable for use on 2 5/16" A-Frame couplers. This jack eliminates the need for hand cranking.



Part No.	Ref. No.	Capacity	Lift	Bracket Height	Retracted Height
80515	275100	2,500 LBS	14"	10 1/8"	24 7/8"

### Leveling Scissor Jack

This Leveling Scissor Jack works with most RV applications. Each jack has a lifting capacity of 5,000 lbs. Available as a pair with handle included on part #BAL-24SJ rated at 10,000 lbs. per pair.

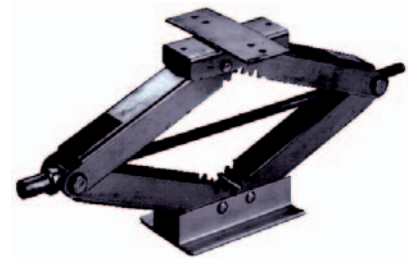

Part No.	Ref. No.	Capacity	Extended Height	Retracted Height
BAL-24SJ	275525	10,000 lbs	23 3/4"	4"
BAL-24011	275575	Replacement jack for #BAL-24SJ		
BAL-24033	275625	Replacement Crank Handle for #BAL-24SJ		

### EZ Jack

The EZ Jack is an easy-to-use, safe and reliable device for changing tires on tandem axle trailers. Made of heavy-duty cast aluminum, it also functions as an excellent wheel chock.



JACKS,  
COUPLERS &  
WINCHES

Part No.	Ref. No.	Capacity
EZ-JACK	275650	20,000 LBS

### Atwood Stabilizer Jack

Designed as an easy-to-use practical means of leveling or stabilizing lightweight trailers of all types, this Jack is also used as a lightweight tongue stand. It can be bolted or welded to the inside or underside of the trailer tongue or frame.



Part No.	Ref. No.	Capacity	Lift	Retracted Height
82300	275200	650 lbs	6"	11 1/2"
80480	275400	Handle Rod for #82300		

### Atwood R.V. Landing Gear

Ideal for 5th wheel trailers, the R.V. Landing Gear is constructed of heavy-gauge steel with a zinc-plated extension tube and drop tube. For additional convenience, add the 75391 electrical motor kit (12 VDC) for automatic operation. The motor also allows manual override.

*Note: The 75391 decreases the capacity rating of the 75333 landing gear to 5,000 lbs.*



Part No.	Ref. No.	Capacity	Lift	Dropleg Travel	Total Adjustment
75333	275105	6,000 lbs	20"	16"	36"
75391	275110	Electric Motor for 75333			

**Fulton Dropleg Jacks**



70SP28F

Minimize cranking of heavy loads with a Dropleg Jack. Fulton's features a 2 1/2" painted outer tube, zinc plated inner tubes and 1" rolled Acme threads.

Part No.	Ref. No.	Static Load	Lift Capacity	Lift	Dropleg Travel	Retracted Height	Type of Wind
70TP28F	267270	7,000 LBS	4,000 LBS	15"	13"	24.30"	TOP
70SP28F	267275	7,000 LBS	4,000 LBS	15"	13"	24.30"	SIDE

**HammerBlow Dropleg Jacks**



The 190 series midsize dropleg jack features 2 1/2" square painted outer tubing and plated inner legs. The 182 series features a 4" square painted outer tubing with optional detachable crank handle, indicated below with part numbers ending in "H". Springloaded inner droplegs also available as indicated below.

JACKS,  
COUPLERS &  
WINCHES

Part No.	Ref. No.	Static Load	Lift Capacity	Lift	Dropleg Travel	Retracted Height	Type of Wind	Handle Included	Spring Loaded	Pin Position
190500	286000	7,000 LBS.	7,000 LBS.	15"	13 1/2"	20.75"	TOP	YES	N/A	N/A
190510	286200	7,000 LBS.	7,000 LBS.	15"	13 1/2"	22.95"	SIDE	YES	N/A	N/A
182304	286220	12,000 LBS.	10,000 LBS.	12 1/2"	13 1/2"	22.5"	TOP	YES	NO	RIGHT
182400	286225	12,000 LBS.	10,000 LBS.	12 1/2"	13 1/2"	27.5"	SIDE	NO	NO	RIGHT
182400H	286250	12,000 LBS.	10,000 LBS.	12 1/2"	13 1/2"	27.5"	SIDE	YES	NO	RIGHT
182417	286260	12,000 LBS.	10,000 LBS.	12 1/2"	13 1/2"	27.5"	SIDE	NO	NO	FRONT
182417H	286265	12,000 LBS.	10,000 LBS.	12 1/2"	13 1/2"	27.5"	SIDE	YES	NO	FRONT
182800	286275	12,000 LBS.	10,000 LBS.	12 1/2"	13 1/2"	27"	SIDE	NO	YES	RIGHT
182800H	286300	12,000 LBS.	10,000 LBS.	12 1/2"	13 1/2"	27"	SIDE	YES	YES	RIGHT
182817	286325	12,000 LBS.	10,000 LBS.	12 1/2"	13 1/2"	27"	SIDE	NO	YES	FRONT
182817H	286330	12,000 LBS.	10,000 LBS.	12 1/2"	13 1/2"	27"	SIDE	YES	YES	FRONT



190500



190510



182304



182400



182417



182800H



## Trailer Equipment Mfg. Dropleg Jacks

A Dropleg Jack for heavier tongue trailers, the T.E.M. Dropleg Jacks contain a 1 1/4" Acme screw with a 2" cast nut, 4" square outer tubing, and a primer painted finish.

Part No.	Ref. No.	Static Load	Lift Capacity	Lift	Dropleg Travel	Retracted Height	Type of Wind	Handle Included	Spring Loaded	Pin Position
TC10	295600	15,000 LBS	10,000 LBS	8"	12"	27"	TOP	YES	NO	RIGHT
T12FP	295605	15,000 LBS	12,000 LBS	12"	12"	27"	SIDE	NO	NO	FRONT
T12FP-H	295610	15,000 LBS	12,000 LBS	12"	12"	27"	SIDE	YES	NO	FRONT
T12FPSL	295615	15,000 LBS	12,000 LBS	12"	12"	27"	SIDE	NO	YES	FRONT
T12FPSL-H	295620	15,000 LBS	12,000 LBS	12"	12"	27"	SIDE	YES	YES	FRONT



TC10



T12FPSL



T12FP

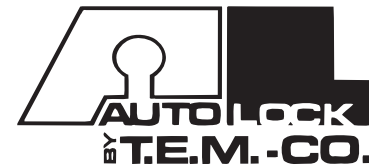

## Binkley Gooseneck Dropleg Jacks

The 48000 Series has been the industry standard for years. The DUALPIN Series offers greater Dropleg stability than single pin models. Its patented quick-release handle makes operation fast, simple and safer, keeping hands away from the load. Both Series of Dropleg Jacks come standard with a 4 3/8" square outer tubing, prime paint finish, handle and handle clip. Both Series also offer the "springloaded" self-retracting leg option.



JACKS,  
COUPLERS &  
WINCHES

Part No.	Ref. No.	Static Load	Lift Capacity	Lift	Dropleg Travel	Retracted Height	Spring Loaded	Handle Included
48000	294000	12,000 LBS	10,000 LBS	13 1/2"	12"	26 1/8"	NO	YES
48000SL	294020	12,000 LBS	10,000 LBS	13 1/2"	12"	26 1/8"	YES	YES
DUALPIN	294030	20,000 LBS	12,500 LBS	12"	14"	26 1/8"	NO	YES
DUALPIN-SL	294040	20,000 LBS	12,500 LBS	12"	14"	26 1/8"	YES	YES
LG8700-31	294200	12,000 LBS	10,000 LBS	13 1/2"	12"	26 1/8"	NO	NO
LG8700-31SL	294205	12,000 LBS	10,000 LBS	13 1/2"	12"	26 1/8"	YES	NO
LGD700-21	294210	20,000 LBS	12,500 LBS	12"	14"	26 1/8"	NO	NO
LGD700-21SL	294220	20,000 LBS	12,500 LBS	12"	14"	26 1/8"	YES	NO



48000 Series

DUALPIN Series

## Binkley Gooseneck Dropleg Jacks - Finish Paint

Binkley offers their 48000 and DUALPIN series with a gray finish paint specifically designed for use on aluminum trailers. Mounting brackets are welded onto the dropleg jack so the jack can be bolted to the trailer rather than welded. This reduces assembly time and preserves the finish quality. The finish paint on both the handle and jack is baked-on at high temperature.



Part No.	Ref. No.	Static Load	Lift Capacity	Lift	Dropleg Travel	Retracted Height	Spring Loaded	Handle Included		
48000-P	294002	12,000 LBS	10,000 LBS	13 1/2"	12"	26 1/8"	NO	YES		
48000SL-P	294022	12,000 LBS	10,000 LBS	13 1/2"	12"	26 1/8"	YES	YES		
DUALPIN-P	294032	20,000 LBS	12,500 LBS	12"	14"	26 1/8"	NO	YES		
DUALPIN-SL-P	294042	20,000 LBS	12,500 LBS	12"	14"	26 1/8"	YES	YES		
LG8700-31-P	294202	12,000 LBS	10,000 LBS	13 1/2"	12"	26 1/8"	NO	NO		
LG8700-31SL-P	294207	12,000 LBS	10,000 LBS	13 1/2"	12"	26 1/8"	YES	NO		
LGD700-21-P	292212	20,000 LBS	12,500 LBS	12"	14"	26 1/8"	NO	NO		
LGD700-21SL-P	292222	20,000 LBS	12,500 LBS	12"	14"	26 1/8"	YES	NO		
LG0083-01-P	297602	Painted Jack Handle								



LGD700-21SL-P

## Binkley Heavy-Duty Dropleg Jacks



These springloaded dropleg jacks are made of 4 3/8" square outer tubing and are available with a single or two-speed gear box. Both the single speed and high gear on the two speed operate at 4.5 turns per inch of lift. Low gear on the two-speed operates at 34.4 turns per inch of travel. The jacks can be used individually or as a set (part # LG4700-30) which includes a connecting tube. Finish is prime paint.



LG4700-32NH

Part No.	Ref. No.	Static Load	Lift Capacity	Lift	Speed	Dropleg Travel	Retracted Height	Handle Included
LG4700-30	294320	50,000 PR	50,000 PR	13 1/2"	SET	12"	29 7/8"	YES
LG4700-31	294300	25,000 LBS	6,500 LBS	13 1/2"	SINGLE	12"	29 7/8"	YES
LG4700-31NH	294305	25,000 LBS	6,500 LBS	13 1/2"	SINGLE	12"	29 7/8"	NO
LG4700-32	294310	25,000 LBS	25,000 LBS	13 1/2"	TWO	12"	29 7/8"	YES
LG4700-32NH	294315	25,000 LBS	25,000 LBS	13 1/2"	TWO	12"	29 7/8"	NO

## Binkley Landing Gear



The 51,000 Series are designed for strength and durability with strong ductile iron gears and 4 3/8" square outer tube. These jacks are typically used on gooseneck trailers requiring very heavy weight bearing capacities. Both the single speed and high gear on the two speed operate at 4.5 turns per inch of travel. Low gear on the two speed operates at 34.4 turns per inch of travel. Finish is prime paint.



LG4701-72NH LG4701-71NH

Part No.	Ref. No.	Static Load	Lift Capacity	Lift	Speed	Retracted Height	Handle Included
LG4701-71NH	294380	35,000 LBS	6,500 LBS	17"	SINGLE	34 1/4"	NO
LG4701-72NH	294370	35,000 LBS	35,000 LBS	17"	TWO	34 1/4"	NO
LG4701-71	294400	35,000 LBS	6,500 LBS	17"	SINGLE	34 1/4"	YES
LG4701-72	294600	35,000 LBS	35,000 LBS	17"	TWO	34 1/4"	YES

JACKS,  
COUPLERS &  
WINCHES

## Binkley Landing Gear Set



The 51,000 Contender Series features "universal mounting brackets" for inside or outside installation on semi-type trailers. On this two speed set, high gear operates at 4.5 turns per inch of travel. Low gear operates at 34.4 turns per inch of travel. Finish is prime paint and handle is included.



Part No.	Ref. No.	Static Load	Lift Capacity	Lift	Speed	Retracted Height
LG4001-70	295500	140,000 LBS	50,000 LBS	17"	TWO	34 1/4"

## Dropleg Jack Accessories



CP42



CPB42

Designed with a 1" pre-drilled handle stub, easily cut to fit all widths of trailers. Pre-cut bushing available for ease of installation.

Part No.	Ref. No.	Description
CP42	297640	Crosspipe extension for dropleg jacks, 42" overall length
CPB42	297645	1 1/2" x 2" Bushing for CP42 jack crossshaft

### A-Frame Jack Support Plates and Flanges

A-Frame Jack Flange and Support Plates are used to provide additional lateral support for A-frame jacks. Replacement Jack Flanges are available for repair or changing bracket mounting heights.

Part No.	Ref. No.	Description	Brand
SPB50	267290	BOTTOM SUPPORT PLATE FOR 2 & 5K, 2.30" I.D. CENTER HOLE	FULTON
80263	274805	BOTTOM SUPPORT PLATE FOR 1K, 2.05" I.D. CENTER HOLE	ATWOOD
83670	275000	BOTTOM SUPPORT PLATE FOR 2 & 5K, 2.28" I.D. CENTER HOLE	ATWOOD
20969	276200	REPLACEMENT A-FRAME FLANGE FOR 2 & 5K, 2.21" I.D. CENTER HOLE	ATWOOD
80004	274795	REPLACEMENT A-FRAME FLANGE FOR 1K, 2.05" I.D. CENTER HOLE	ATWOOD ATWOOD

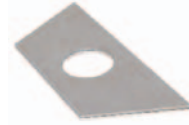

83670



20969

### Jack Feet and Casters

A selection of Jack Feet and Casters for all A-Frame and tubular jacks. Atwood Feet and Casters feature "twist-lock" mounting for easy attachment and removal on Atwood jacks.

Part No.	Ref. No.	Description	Brand
80259	274020	2" x 6" POLY CASTER, FOR 1K JACKS W/1 3/4" TUBE	ATWOOD
80552	274200	2"x6" POLY CASTER, FOR 2 & 5K JACKS W/2" TUBE (CASTER RATED AT 1,000 LBS CAP )	ATWOOD
82650	274400	JACKFOOT FOR 2 & 5K JACKS W/2" TUBE	ATWOOD
82660	274600	6 3/4" TALL JACKFOOT FOR 2 & 5K W/2" TUBE	ATWOOD
017125	287100	1 3/4"x 6" STEEL CASTER W/LOCKPIN, FOR 2 & 5K JACKS W/2" TUBE (CASTER RATED AT 1,000 LB CAP.)	H-BLOW
018173	287600	4" TALL JACKFOOT FOR 2 & 5K W/2" TUBE	H-BLOW
CP555	267294	JACK CASTER FOR 2K & 5K A-FRAME JACK	FULTON



80552

80259



82660

82650

JACKS,  
COUPLERS &  
WINCHES

### Swivel Jack Mounting Brackets

For mounting snap ring and pipe swivel jacks. Choose the style to suit your need and jack type.

Part No.	Ref. No.	Description	Brand
87501	270900	WELD-ON BRACKET & SNAP RING FOR 1K	ATWOOD
87502	270910	BOLT-ON BRACKET & SNAP RING FOR 1K	ATWOOD
81271	271800	WELD-ON PIPE SWIVEL BRACKET FOR 2K, 5/8" PIN HOLE DIAMETER	ATWOOD
82500	272000	WELD-ON PIPE SWIVEL BRACKET FOR 5K, 7/8" PIN HOLE DIAEMTER	ATWOOD
005006	286400	WELD-ON PIPE SWIVEL BRACKET FOR 5K, 5/8" PIN HOLE DIAMETER	H-BLOW
005024	286600	WELD-ON PIPE SWIVEL BRACKET FOR 7K, 5/8" PIN HOLE DIAMETER	H-BLOW
015904	286800	REPLACEMENT RING ONLY, FOR MOST SNAP RING SWIVEL JACKS	ALL
015909	287000	WELD-ON BRACKET ONLY, USE W/015904 SNAP RING	H-BLOW

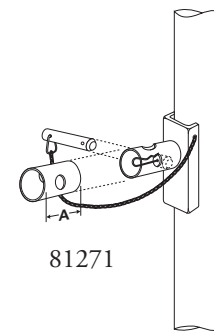

81271

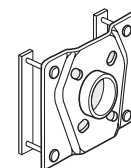

87502

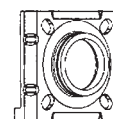

87501



### Redline Jack Repair Parts



Redline jack repair kits include the parts needed to perform the most common jack repairs. Packaged for pegboard display.

Part No.	Ref. No.	Description
JP02-010	264350	Topwind handle, fits Atwood, Shelby, Fulton jacks
JP02-020	264355	Topwind handle, fits HammerBlow 2-5K jacks
JP02-030	264360	Topwind handle, fits Fulton & HammerBlow 7K dropleg jacks
JP02-100	264400	9/16" Pin & Chain for HammerBlow pipe mount jacks
JP02-110	264410	5/8" Pin for HammerBlow dropleg jacks (190)
JP02-150	264475	1/2" Plunger pin assembly for HammerBlow swivel jacks
JP02-200	264480	Snap Ring, fits most swivel jacks

### Binkley Jack Repair Parts



Part No.	Ref. No.	Description
LG0083-01	297600	6" HANDLE FOR DROPLEG JACK
LG0083-02	297615	6" HANDLE FOR DROPLEG JACK, CLIP TURNED 45 DEGREE
LG0083-03	297625	12" HANDLE FOR DROPLEG JACK
LG0085	297630	CRANK HANDLE HANGER
LG0094	297650	CONNECTING PIPE FOR TANDEM JACKS, 1" O.D. X 64 1/2" LONG
LG1466	297800	CROSS SHAFT FOR DROPLEG JACK 48000
LG1462	298000	CROSS SHAFT BUSHING FOR DROPLEG JACK 48000
LG0266	298100	STRUT BRACKET FOR LG4001-70 LANDING GEAR
LG0531-02	298600	PINION GEAR FOR LANDING GEAR 50000 SERIES
LG0310-06	298800	FOOT FOR DROPLEG JACK 48000
LG0490	299200	RELEASE PIN FOR DROPLEG JACK 48000
LG1494-01	299400	UPPER MITER GEAR FOR DROPLEG JACK 48000
LG1495-01	299600	LOWER MITER GEAR WITH HUB FOR DROPLEG JACK 48000
PP0013-70	299800	THRUST BEARING FOR DROPLEG JACK 48000
PP0014-07	300000	1/4" X 1 1/2" DRIVE LOCK PIN
PP0014-18	300200	3/8" X 1 1/2" DRIVE LOCK PIN
PP0014-59	300400	3/16" X 1 1/2" COTTER PIN
LG0326	300425	TOP CAP FOR DROPLEG JACK 48000 (OLD STYLE)
LG0880	300430	TOP CAP FOR DROPLEG JACK 48000 (NEW STYLE)
PP0018-02	300600	WOODRUFF KEY FOR BINKLEY JACK 50000 SERIES JACKS
LG0266	300610	STRUT BRACKET FOR BINKLEY LANDING GEAR
FW0172	300800	JAW FOR BINKLEY 5TH WHEELS
PP0020-21	301200	JAW EXTENSION SPRING FOR BINKLEY 5TH WHEELS
FW0173	301400	PIVOT CLEVIS PIN, 1 1/4" X 2 1/4" FOR BINKLEY 5TH WHEEL
PP0014-45	301600	CLEVIS PIN 1" X 4" FOR BINKLEY 5TH WHEEL
PP0020-07	301800	JAW SPRING FOR BINKLEY 5TH WHEEL

### HammerBlow Jack / Coupler Repair Parts



Part No.	Ref. No.	Description
017207	287200	CASTER BUSHING FOR RACK POST 08006, 018007
017229	287400	STEEL WHEEL FOR RACK POST 018006
015500	288220	CAP FOR SW JACKS
024190	288400	RELEASE HANDLE FOR 2B & 4B COUPLERS
024192	288600	COLLAR CLIP FOR 2B AND 4B COUPLERS
024193	288800	DRIVE RIVET FOR RELEASE HANDLE
025201	289000	SNAPPER PIN & CHAIN FOR PIN RELEASE COUPLERS
025230	289200	COUPLER RELEASE PIN FOR 024190 HANDLE

## Shelby Single Speed Winches

Shelby Winches are engineered and built tough to be used in a variety of applications. All gears are heat-treated high carbon SAE 1050 steel. Reel and pinion gear shafts turn on oil-impregnated bearings for smooth operation. Winch frames are embossed for added strength. Zinc plating fights against corrosion. Every Shelby Winch component is designed to withstand years of rigorous use.



Part No.	Ref. No.	Capacity	Gear Ratio	Ratchet Style
5400	408800	400 LBS	RATCHET	1-WAY
5402	408810	600 LBS	3.1:1	1-WAY
5403	409010	900 LBS	3.1:1	1-WAY
5404	409410	1,200 LBS	4.1:1	1-WAY
5405	409420	1,400 LBS	4.1:1	2-WAY
5407	409610	1,700 LBS	5.1:1	2-WAY
5408	409810	1,900 LBS	5.1:1	2-WAY
5409	409815	2,100 LBS	5.1:1	2-WAY
1957	412410	REPLACEMENT HANDLE FOR 5402, 6" LONG		
0937	412420	REPLACEMENT HANDLE FOR 5403, 5404, 5405, 7" LONG		
2702	412440	REPLACEMENT HANDLE FOR 5407, 5408, 8" LONG		
0854	412430	REPLACEMENT HANDLE FOR 5409, 10" LONG		

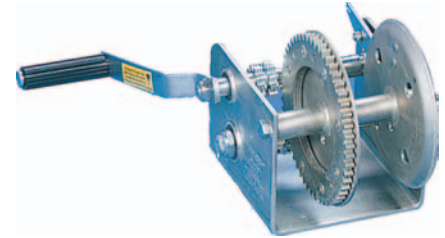

## Fulton Single Speed Winches

Fulton Winches feature heat-treated high carbon SAE 1050 steel gears, with minimum space between them and positive locking for proper alignment. The "Comfort Grip" handle is a standard item on each Fulton Winch and zinc coating protects them from corrosion.



Part No.	Ref. No.	Capacity	Gear Ratio	Ratchet Style
T600	408850	600 LBS	3.1:1	1-WAY
T900	409210	900 LBS	3.1:1	1-WAY
T1300	409416	1,200 LBS	4.1:1	1-WAY
T1500	409521	1,500 LBS	4.1:1	2-WAY
T1801	409710	1,800 LBS	5.1:1	2-WAY



JACKS,  
COUPLERS &  
WINCHES

## Shelby Agricultural / Industrial Winches

Designed for use with steel cable, the Shelby Ag./Ind. Winches are especially adapted to the rigorous demands of agricultural and industrial jobs. The brake mechanism is self-activated to automatically lock the load securely when the handle is released and is covered for protection against oil, dirt and the elements. To ensure long life, the ratchet, pawl, and gears are heat-treated, the shafts are made of high-tensile steel, and the bushings are oil-impregnated.



Part No.	Ref. No.	Capacity	Gear Ratio	Ratchet Style
5351	410500	1,000 LBS	4.1:1	AUTOMATIC BRAKE
5352	410700	1,500 LBS	5.1:1	AUTOMATIC BRAKE
5353	410900	2,500 LBS	15.8:1	AUTOMATIC BRAKE
2089	412460	REPLACEMENT HANDLE FOR 5351, 5352, 5353, 11" LONG		

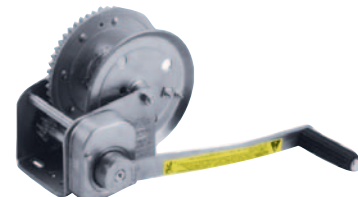

### Shelby Two Speed Winches



To change speeds on your Shelby Two Speed Winch simply press the locking lever and shift the handle from side to side which will allow you to change gears or free spool. The handle is designed not to spin while in free spool position. All gears are heat-treated and their ratios offer easier cranking of heavy loads.

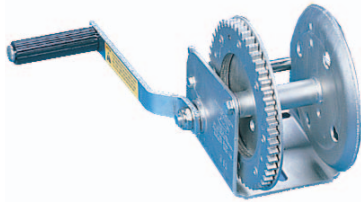

Part No.	Ref. No.	Capacity	Gear Ratio	Ratchet Style
5460	409835	2,300 LBS	4.1:1 / 11.8:1	2-WAY
5470	410100	2,800 LBS	5.1:1 / 14.7:1	2-WAY
5480	410150	3,200 LBS	5.1:1 / 14.7:1	2 WAY
5481	410175	3,200 LBS	5.1:1 / 14.7:1	2-WAY W/ HAND BRAKE
2400	412450	REPLACEMENT HANDLE FOR 5460, 5470,5480, 10" LONG		

### Fulton Two Speed Winches



The Fulton Two Speed Winch makes loading large boats and trailers easy with a shift lock to hold the shaft in the desired gear ratio. Free wheeling and neutral positions play out the line without spinning the handle for safer operation.



Part No.	Ref. No.	Capacity	Gear Ratio	Ratchet Style
T3700	410200	3,700 LBS	5.1:1 / 15.8:1	2-WAY
9235	412400	REPLACEMENT HANDLE FOR T3700, 10"LONG		

JACKS,  
COUPLERS &  
WINCHES

### Winch Strap

Polyester Webbing with a forged slip hook on one end. The looped end of the 5604 is ideal for personal watercraft use.

Part No.	Ref. No.	Dimensions	Capacity
6030	412600	2" X 20" FT	3,500 LBS
5604	412550	2" X 15" FT	3,500 LBS

### Ramsey Electric Winches



The RW2500 is designed primarily for general utility and light duty front mount vehicle use. Features a planetary gear set which transmits torque from a permanent magnet 12-volt D.C. motor. Circuit breakers prevent overheating by shutting motor off. The RW2500's motor is inside its drum which gives better pulling power. Its light weight cast aluminum housing weighs less than 20 lbs. Self locking mechanism and power-in / power-out feature allows for complete control of load. Optional 12 ft. remote control kit with solenoid allows individual to operate Winch and control load at a distance from the Winch.



The REP5000H features a highly efficient 3 stage planetary gear set which transmits torque from a permanent magnet 12-volt D.C. motor for fast line speed. A safe positive cam action clutch allows free spooling for quick cable deployment. An automatic load holding brake is designed to hold the full rated capacity of the Winch. Winch comes with Hawse Fairlead. Pictured with optional Roller Fairlead.

Part No.	Ref. No.	Description	Line Pull	Cable Length	Type of Control
RW2500*	412720	ELECTRIC WINCH	2,500 LB	25 FT	MANUAL
REP5000H	412730	ELECTRIC WINCH	5,000 LB	80 FT	12 FT ROMOTE
RW2500-MK	412722	HAWSE FAIRLEAD MOUNTING KIT FOR RW2500			
RW2500-RC	412723	REMOTE CONTROL FOR RW2500			

\* Remote Control Sold Separately



# Towing Accessories

Class III & IV Bolt-on Receivers	G-2 - G-4
Bike Rack	G-5
Cargo Platform	G-5
Weight Distribution Hitches	G-5
Bumper Receiver Hitches and Receiver Tubes	G-5
Drop Hitches	G-5
Cushioned Ball Mounts	G-6
Receiver Ball Mounts and Pintle Mounts	G-6
Transmission Coolers	G-7
Receiver Accessories	G-7
Triple Ball Mount	G-7
Interchangeable Hitch Balls	G-8
Hitch Ball Covers	G-8
Hitch Pins	G-8
Redline Packaged Hitch Balls	G-8
Hitch Balls	G-9
Folding Gooseneck Hitch Ball	G-10
Gooseneck Hitch Plates	G-10
Gooseneck Channels	G-10
B & W Gooseneck Hitch & RV 5th Wheel	G-11
Redline "Pull & Twist" Gooseneck Hitch Ball	G-11
Redline Underbed Hitch	G-11
Redline Gooseneck Hitch Mounting Kits	G-11
Holland/Binkley 5th Wheel	G-12
Hijacker Installation Mounting	G-12
Hijacker R.V. 5th Wheel & Gooseneck Systems	G-12
King Pins	G-12

**Class III & IV Bolt-on Receivers**

**CHEVROLET & GMC Full Size Pickups**

Model	Year	Part No.	Ref. No.	Weight Carry	Weight Distributing	NO Drill	Style
FULL SIZE PICKUP 2500HD/3500	2001	RH82170	314974	6000	10000		C
	2001	RH82150	314933	9000	12000		A
FULL SIZE PICKUP 1500/2500 HEAVY DUTY	99-01	RH8184	314975	6000	10000	X	B
		RH8251	314934	9000	12000	X	A
FULL SIZE C/K PICKUP (OLD BODY STYLE)	88-00	RH8103	314978	5000	10000	X	C
		RH8249	314935	9000	12000		A
FULL SIZE PICKUP (OLD BODY STYLE) MULTI FIT LONG BED ONLY	63-98	RH8109	315215	5000	10000		D
		RH7300	315145	7500	10000		H

**CHEVROLET & GMC Mid-size Pickups, SUVs, & Vans**

Model	Year	Part No.	Ref. No.	Weight Carry	Weight Distributing	NO Drill	Style
ASTRO/SAFARI Mini-Van	EXTENDED LENGTH 89-01	RH7364	314905	3500	5000	X	D
	STANDARD LENGTH 85-94	RH7368	314910	3500	5000	X	C
BLAZER / JIMMY (DOWN SIZE)	98-01	RH8169	314998	4000	6000	X	E
	95-97	RH8110	314999	4000	6000	X	E
BLAZER (PULL SIZE)	92-94	RH7409	314930	5000	10000	X	C
	81-91	RH7389	314920	5000	8000		C
S-10 / S-15 / SONOMA PICKUPS	98-01	RH8161	314994	4000	6000		D
	94-97	RH8108	314995	4000	6000	X	C
SUBURBAN	92-99	RH7409	314930	5000	10000	X	C
	HEAVY DUTY 92-99	RH8248	314900	9000	12000		A
TAHOE, YUKON	92-99	RH7409	914930	5000	10000	X	C
VAN FS EXPRESS / SAVANA	96-01	RH8139	314997	5000	10000	X	C
VAN FS 10,20,30 SERIES	78-95	RH7425	314940	5000	10000	X	A

TOWING ACCESSORIES







**Class III & IV Bolt-on Receivers**

**DODGE Full Size Pickups**

Model	Year	Part No.	Ref. No.	Weight Carry	Weight Distributing	NO Drill	Style
FULL SIZE PICKUP	Heavy Duty	94-01	RH8252 315088	9000	12000		A
		94-01	RH8178 315136	5000	10000	X	E
FULL SIZE PICKUP	63-93		RH8101 315180	5000	8000		B
			RH8107 315210	5000	10000		H
FULL SIZE PICKUP	Multi-Fit	63-93	RH8109 315215	5000	10000		D
	Multi-Fit	63-98	RH7300 315145	7500	10000		H

**DODGE, CHRYSLER, PLYMOUTH Mid-size Pickups, SUV's & Vans**

Model	Year	Part No.	Ref. No.	Weight Carry	Weight Distributing	NO Drill	Style
DAKOTA PICKUP	87-01	RH8147	315104	5000	7500		B
DURANGO	98-01	RH8160	315130	5000	7500	X	I
MINI-VAN CARAVAN/TOWN & COUNTRY/VOYAGER	96-00	RH6537	315093	3500	5000	X	F
	84-95	RH6597	315095	3500	3500		F
VAN Full-Size	94-97	RH7404	315118	5000	10000	X	B

**FORD Full Size Pickups**

Model	Year	Part No.	Ref. No.	Weight Carry	Weight Distributing	NO Drill	Style
F-150&F-250 (UNDER 8500 GVWR)	97-98		RH8176 315082	5000	10000		I
			RH8250 315002	9000	12000		A
F-250 & F-350 SUPER DUTY	99-01		RH8176 315082	5000	10000		I
			RH8250 315002	9000	12000		A
FULL SIZE PICKUP	Heavy Duty	73-96	RH8101 315180	5000	8000	X	B
		80-96	RH8246 315010	9000	12000		A
FULL SIZE PICKUP (OLD BODY STYLE)	Multi-Fit	60-98	RH8109 315215	5000	10000		D
			RH7300 315145	7500	10000		H

**FORD / LINCOLN / MERC Mid-Size Pickups, SUV's & Vans**

Model	Year	Part No.	Ref. No.	Weight Carry	Weight Distributing	NO Drill	Style
AEROSTAR	89-97	RH7370	315015	3500	5000		B
EXPEDITION / LINCOLN NAVIGATOR	97-01	RH8145	315075	5000	10000		E
EXPLORER / MOUNTAINEER	98-01	RH8168	315068	5000	6000		E
	91-97	RH8126	315070	5000	6000	X	C
BRONCO II	83-90	RH7448	315065	3500	5000		C
ECONOLINEVAN	92-01	RH7408	315035	5000	10000		E
	75-91	RH7436	315055	5000	10000		C
RANGER PICKUP	98-01	RH8162	315040	4000	6000		D
	91-97	RH7410	315045	3500	5000		C
WINDSTAR	95-98	RH6515	315020	3500	N/A		G
	Class II 99-01	RH66650	315021	3500	N/A		F

TOWING  
ACCESSORIES



G

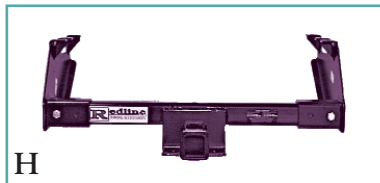

H



I

**Class III & IV Bolt-on Receivers**

JEEP							
Model	Year	Part No.	Ref. No.	Weight Carry	Weight Distributing	NO Drill	Style
CHEROKEE & WAGONEER	84-01	RH7361	315108	3500	5000	X	C
GRAND CHEROKEE	99-01	RH8180	315120	5000	8000	X	E
	93-98	RH7412	315125	5000	10000	X	B
WRANGLER	87-97	RH5961	315140	2000	N/A		G
NISSAN							
Model	Year	Part No.	Ref. No.	Weight Carry	Weight Distributing	NO Drill	Style
PATHFINDER	96-01	RH8136	316110	5000	N/A	X	D
PICKUP Long Bed & Short Bed	86-97	RH81630	316018	3500	4000		D
FRONTIER	98-01	RH81630	316018	5000	6000		D
TOYOTA							
Model	Year	Part No.	Ref. No.	Weight Carry	Weight Distributing	NO Drill	Style
4-RUNNER	97-01	RH8137	316105	5000	N/A	X	I
TUNDRA	00-01	RH8188	316090	5000	10000		I
TACOMA PICKUP	95-01	RH8159	316080	5000	N/A	X	D
T-1004WD	93-98	RH81550	316086	5000	N/A	X	B
ISUZU							
Model	Year	Part No.	Ref. No.	Weight Carry	Weight Distributing	NO Drill	Style
RODEO	90-97	RH8112	316120	3500	5000		I

TOWING  
ACCESSORIES

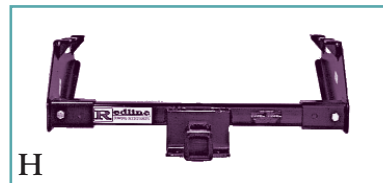

## Bumper Receiver Hitches and Receiver Tubes

Choose from our standard Step Bumper Hitch Box or the Bumper Receiver Hitch for an alternative light duty 2" receiver. For custom building your own receiver hitch, three lengths of receiver tubes are available.

Part No.	Ref. No.	Description
RH7585	314970	BUMPER RECEIVER HITCH 88-98 CHEV, GMC W/FACTORY BUMPERS (400 LB. TONGUE, 4000 LB. GR)
SBH7603	318150	2" STEP BUMPER HITCH, UNIVERSAL FIT W/FLAT MOUNTING PLATE, 6 BOLT HOLES
SBH7511	318175	2" STEP BUMPER HITCH, UNIVERSAL FIT W/FLAT MOUNTING PLATE, 4 BOLT HOLES
RB12	318600	12" RECEIVER TUBE FOR 2" SQUARE HITCH BARS
RB24	318625	24" RECEIVER TUBE FOR 2" SQUARE HITCH BARS
RB36	318800	36" RECEIVER TUBE FOR 2" SQUARE HITCH BARS



## Drop Hitches

Bolt to rear of a pickup step bumper. These Drop Hitches give a lower hitch point to the trailer, allowing a level ride for towing.

Part No.	Ref. No.	Description
503	318200	4" DROP REAR HITCH
503K	318250	4" DROP REAR HITCH, W/HBK34 MOUNTING BOLT KIT
504	318400	6" DROP REAR HITCH
504K	318450	6" DROP REAR HITCH, W/HBK34 MOUNTING BOLT KIT
HBK34	318475	MOUNTING BOLT KIT FOR DROP HITCH



## Weight Distribution Hitches

For use when towing trailers with heavier tongue weights. These Hitches apply leverage between the tow vehicle and trailer resulting in a more level ride with less stress on the rear of the tow vehicle. Use with a 2" receiver hitch.

Part No.	Ref. No.	Description
1009	318075	WEIGHT DISTRIBUTION HITCH WITH ADJUSTABLE BALL MOUNT AND HARDWARE (DOES NOT INCLUDE HITCH BALL)
2000	318080	RIGHT HAND MOUNT SWAY CONTROL FOR USE WITH 1009 HITCH, INCLUDES SWAY CONTROL HITCH BALL
1709	318090	REPLACEMENT 1 1/4" SWAY CONTROL HITCH BALL 5/8" DIA. SHANK, FOR USE WITH 1009, 2000



TOWING  
ACCESSORIES

## Cargo Platform

Extend your cargo space with this hitch mounted platform. The 20" x 60" platform is for use with 1-1/4" and 2" receiver hitches and features a mesh floor, convenient tie loops and a 500 lb. capacity. The powder coat finish helps prevent corrosion.

Part No.	Ref. No.	Description
TA08-500	318550	HITCH MOUNT CARGO CARRIER, BOXED



## Bike Rack

Yet another way to increase the utility of your receiver hitch, this 4-bike rack swings down for easy loading and access to the vehicle cargo area. Padded, lockable clamps protect the bike from abrasion and theft.

Part No.	Ref. No.	Description
BR9087	318505	4 BIKE CARRIER FOR 2" RECEIVER HITCH
BRGBADP	318515	BIKE RACK ADAPTER FOR GIRLS BIKES



## Selecting a Ball Mount with the Correct Rise or Drop

### Selecting a Ball Mount with the Correct Rise or Drop:

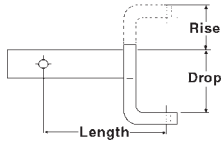

Follow the simple steps illustrated below to determine the ball mount with enough rise or drop to keep the trailer in a level position.

#### To Measure Ball Mount Rise:

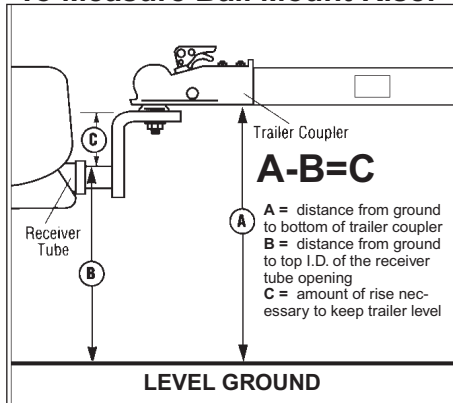

#### To Measure Ball Mount Drop:

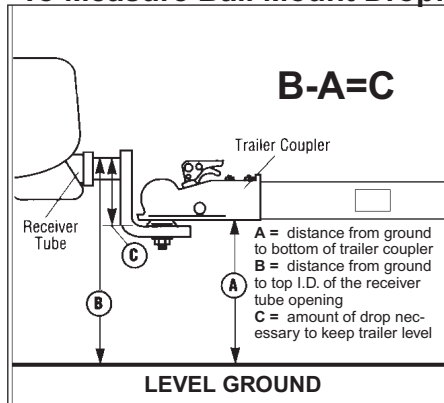

## Receiver Ball Mounts and Pintle Mounts

Designed to fit 2" I.D. receiver tube, ball mounts raise or lower ball height for proper trailer towing.



Part No.	Ref. No.	Description	Ball Shank Hole Size	Shank Length	Capacity
BM2	319003	2" DROP OR STRAIGHT	1"	8"	5,000 LBS
BM2-CHROME	319004	CHROME 2" DROP OR STRAIGHT	1"	8"	5,000 LBS
BM2HD	319005	HEAVY DUTY, 2" DROP	1 1/4"	9"	9,000 LBS
BM4	319203	4" DROP OR 2" LIFT	1"	8"	5,000 LBS
BM4-CHROME	319204	CHROME 4" DROP OR STRAIGHT	1"	8"	5,000 LBS
BM4HD	319205	HEAVY DUTY, 4" DROP	1 1/4"	9"	9,000 LBS
BM6	319403	5 1/4" DROP OR 4" LIFT	1"	9"	5,000 LBS
BM6HD	319405	HEAVY DUTY, 6" DROP	1 1/4"	9"	9,000 LBS
BM8	319503	8" DROP OR 6 1/2" LIFT	1"	9 1/2"	5,000 LBS
PM6990	319628	PINTLE MOUNT ADAPTER, 7 1/4" PLATE, 3 1/2" DROP	N/A	8 5/8"	9,000 LBS

## Cushioned Ball Mounts

Designed to reduce the shock associated with starting and stopping while towing and shifting loads. For use with 2" receiver tubes.

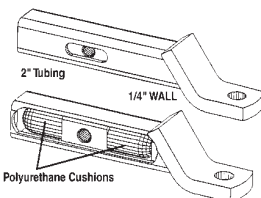

Part No.	Ref. No.	Description	Ball Shank Hole Size	Shank Length	Capacity
AMSC2	319520	2" DROP, SOCKET DEPTH OF 4 5/8" OR MORE	1"	8"	10,000 LBS
AMSC4	319530	4" DROP, SOCKET DEPTH OF 4 5/8" OR MORE	1"	8"	10,000 LBS

## Triple Ball Mount

Designed to aid in towing multiple tongue sized couplers with only one ball mount. This product has 1 7/8", 2" & 2 5/16" balls welded into place. The mount has a 6,000 lb capacity for the 1 7/8" ball and 10,000 lb capacity for the 2" & 2 5/16" balls.



Part No.	Ref. No.	Description	Receiver Tube Size	Shank Length
TBM1620	309075	TRIPLE BALL MOUNT	2"	8"

## Receiver Accessories

We have hitch pins available in bulk or packaged for easier display. Also, prevent theft of draw bars with a locking hitch pin. Other accessories are listed below.

### Receiver Hitch Pins

Part No.	Ref. No.	Description
RHPP-1	319740	RECEIVER HITCH PIN, 5/8" X 3", WITH KEEPER (BULK)
HP583	319750	RECEIVER HITCH PIN, 5/8" X 3", WITH KEEPER (PACKAGED)
RHPP-2	319745	RECEIVER HITCH PIN, 1/2" X 3", WITH KEEPER (BULK)
HP12	319755	RECEIVER HITCH PIN, 1/2" X 3" WITH KEEPER (PACKAGED)



DB-3

### Locking Receiver Hitch Pins

Part No.	Ref. No.	Description
DB-3	319800	LOCKING RECEIVER HITCH PIN, 5/8" X 3"
TM31	319804	HITCHLOCK & LOCK FOR TRIGGER COUPLERS, KEYED ALIKE
TM32	319806	HITCHLOCK & LOCK FOR YOKE TYPE COUPLERS, KEYED ALIKE
18-2058	319810	LOCKING RECEIVER HITCH PIN, 5/8" X 3"



7506

### Receiver Tube Collars & Covers

Part No.	Ref. No.	Description
HBB1	320000	HITCH BAR BUSHING, REDUCES 1" HOLE TO 3/4"
RBC250	320200	RECEIVER BAR COLLAR
7505	320225	2" RECEIVER TUBE COVER, CHROME
7506	320250	2" RECEIVER TUBE COVER, BLACK



18-2058



7506



7505



RHPP-2

TOWING  
ACCESSORIES

## Transmission Oil Coolers

The "thin-line", stacked plate design of this Transmission Oil Cooler guards against damage and allows application in hard-to-fit areas. The aluminum embossed plated design brings the oil closer to the cooling air for 30% greater cooling efficiency than the tube/fin type. Heat flows directly from fluid to plate to air. Oil flows at a higher rate allowing it to cool more oil in a shorter period of time. The coolers come with easy-to-use instructions and hardware for Quick Mount installation.



Part No.	Ref. No.	Range	Width	Length	Thickness	No. of Plates	Heat Rejection BTU / HR	GCWR Rating (lbs)
4334A	485400	MED.DUTY	4"	11"	3/4"	36	7,800	7,000-11,000
4335A	485600	HEAVY DUTY	7 1/4"	11"	3/4"	72	13,500	11,000-18,000

Note: For use on vehicles with 5/16 or 3/8 automatic transmission return lines GCWR = Gross Combined Weight Rating

## Hitch Pins

Hitch Pins are available in a variety of sizes for utility wagons, implements, etc. or when a locking pin is desired.

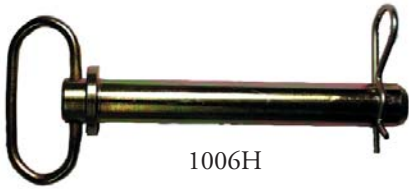

1006H

Part No.	Ref. No.	Description
12H	320400	HITCH PIN 1/2" x 3 1/2" WITH HITCH PIN KEEPER
58H	320600	HITCH PIN 5/8" x 4 1/2" WITH HITCH PIN KEEPER
586H	320800	HITCH PIN 5/8" x 6" WITH HITCH PIN KEEPER
34H	321000	HITCH PIN 3/4" x 4 1/2" WITH HITCH PIN KEEPER
346H	321200	HITCH PIN 3/4" x 6" WITH HITCH PIN KEEPER
1006H	321220	HITCH PIN 1" X 6" WITH HITCH PIN KEEPER
HPK3	321400	HITCH PIN KEEPER, 1 5/8" LONG
HPK9	321600	HITCH PIN KEEPER, 2 9/16" LONG

## Hitch Ball Covers

Available in black, red or silver, these attractive hitch ball covers add the finishing touch to any tow vehicle! These high-quality molded vinyl covers feature a "pocket" for flat 4-way trailer connectors, keeping the connector tucked out of the way when not in use.



Part No.	Ref. No.	Description
HBC-1R	313625	REDLINE HITCH BALL COVER, RED, FITS 1 7/8" & 2" BALLS
HBC-1B	313630	REDLINE HITCH BALL COVER, BLACK, FITS 1 7/8" & 2" BALLS
HBC-1S	313635	REDLINE HITCH BALL COVER, SILVER, FITS 1 7/8" & 2" BALLS

## Interchangeable Hitch Balls

Simplify hitch ball size changes with Interchangeable Hitch Balls, no tools required. The hex shaft attaches to the tow vehicle and the balls can be removed from the shaft with the simple push of a pin.

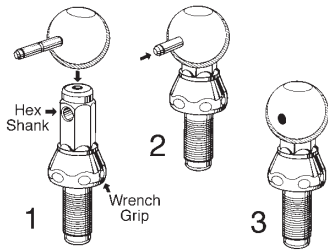

Part No.	Ref. No.	Ball Size	Shank Diameter	Finish	Capacity
AB57800	309085	1 7/8" & 2"	3/4"	CHROME	3,500 LBS
AB57900	309087	1 7/8", 2" & 2 5/16"	1"	CHROME	8,000 LBS
AB57901	309089	1 7/8" & 2"	1"	CHROME	8,000 LBS
AB11500	309095	STORAGE CASE FOR INTERCHANGEABLE HITCH BALL			

## Redline Packaged Hitch Balls



The most popular forged Hitch Balls, in attractive clam shell packaging for Your Retail Sales! For pegboard or shelf display.



Part No.	Ref. No.	Ball Size	Shank Diameter	Shank Length	Finish	Capacity
TA02-025	309015	1 7/8"	3/4"	2 1/2"	CHROME	2,000 LBS
TA02-045	309025	1 7/8"	1"	2"	CHROME	2,000 LBS
TA03-025	309040	2"	3/4"	2 1/2"	CHROME	3,500 LBS
TA03-045	309050	2"	1"	2 1/2"	CHROME	5,000 LBS
TA03-065	309055	2"	1"	2 7/8"	CHROME	5,000 LBS
TA04-020	309065	2 5/16"	1"	2"	CHROME	5,000 LBS
TA04-040	309070	2 5/16"	1 1/4"	2 1/4"	CHROME	7,500 LBS

## Hitch Balls

1 7/8" Ball							
Part No.	Ref. No.	Ball Size	Shank Diameter	Shank Length	Finish	Rise	Capacity
17834ZLS	309100	1 7/8"	3/4"	2 5/16"	ZINC	N/A	2,000 LBS
17834CLS	309500	1 7/8"	3/4"	2 5/16"	CHROME	N/A	2,000 LBS
1781ZLS	309790	1 7/8"	1"	2 1/8"	ZINC	N/A	2,000 LBS
1781CLS	309900	1 7/8"	1"	2 1/8"	CHROME	N/A	2,000 LBS



2" Ball							
Part No.	Ref. No.	Ball Size	Shank Diameter	Shank Length	Finish	Rise	Capacity
234ZLS	310150	2"	3/4"	2 5/16"	ZINC	N/A	3,500 LBS
234CLS	310590	2"	3/4"	2 5/16"	CHROME	N/A	3,500 LBS
21ZLS	310790	2"	1"	2 1/8"	ZINC	N/A	5,000 LBS
21CLS	311190	2"	1"	2 1/8"	CHROME	N/A	5,000 LBS
80200	311400	2"	1"	2"	FORGED	N/A	5,000 LBS
211RM	311500	2"	1"	2"	ZINC	1"	5,000 LBS
212RM	311600	2"	1"	2"	ZINC	2"	3,500 LBS
21HT	311700	2"	1"	2 1/8"	HEAT TREATED	N/A	7,000 LBS
2114CLS	311725	2"	1 1/4"	2 1/4"	CHROME	N/A	7,500 LBS
2114ZLS	311750	2"	1 1/4"	2 1/4"	ZINC	N/A	7,500 LBS



2 5/16" Ball							
Part No.	Ref. No.	Ball Size	Shank Diameter	Shank Length	Finish	Rise	Capacity
2516-1LS	311850	2 5/16"	1"	2 1/8"	ZINC	N/A	6,000 LBS
2516-114	312000	2 5/16"	1 1/4"	2 1/4"	ZINC	N/A	12,000 LBS
2516-114LS	312200	2 5/16"	1 1/4"	3 1/4"	ZINC	N/A	9,000 LBS
2516-114-1	312400	2 5/16"	1 1/4"	2 1/4"	ZINC	1"	7,000 LBS
2516-114-1LS	312435	2 5/16"	1 1/4"	3 1/4"	ZINC	1"	7,000 LBS
2516-114-2	312600	2 5/16"	1 1/4"	2 1/2"	ZINC	2"	5,000 LBS
2516-112-2	312650	2 5/16"	1 1/2"	2 3/4"	MACHINE	2"	30,000 LBS
80211	312800	2 5/16"	1 3/8"	2 1/2"	FORGED	N/A	13,000 LBS
81371	313000	2 5/16"	1 3/8"	2 1/2"	FORGED	N/A	40,000 LBS
2516-114-HT	313025	2 5/16"	1 1/4"	2 1/8"	MACHINE	N/A	30,000 LBS
5F	313200	2 5/16"	1 3/8"	3 1/4"	MACHINE	1"	30,000 LBS
2516-138-1	313220	2 5/16"	1 3/8"	3 1/4"	MACHINE	1"	30,000 LBS
2516-112CT	313400	2 5/16"	1 1/2"	3 1/2"	ZINC	N/A	10,000 LBS
2516-2CT	313425	2 5/16"	2"	3 1/2"	MACHINE	N/A	10,000 LBS



TOWING  
ACCESSORIES

3" Ball							
Part No.	Ref. No.	Ball Size	Shank Diameter	Shank Length	Finish	Rise	Capacity
32M	313800	3"	2"	3 1/4"	MACHINE	N/A	30,000 LBS

## Smooth Shank Hitch Balls

For use when towing gooseneck trailers with a wide variety of couplers, this Hitch Ball design can be used with the GNPC-1 Eye for pin-type couplings.

Part No.	Ref. No.	Ball Size	Shank Diameter	Shank Length	Description	Capacity
2516-2316SM	313600	2 5/16"	2 3/16"	4"	BALL WITHOUT COLLAR	30,000 LB.
GNPC-1	314000	N/A	2 3/16"	4"	EYE WITHOUT COLLAR	NOT RATED
GNC	314200	N/A	2 3/16" I.D.	N/A	COLLAR ONLY	N/A



2516-2316SM

GNPC-1

### Gooseneck Channels

A real time saver for Gooseneck hitch installers! When equipping pick-ups for gooseneck trailer towing, use pre-cut channels for under-the-bed installation of hitch balls with either a 1 1/4" or 2 3/16" shank. These 6" wide channels are available in 34", 38" or 42" lengths to fit most 1/2 thru 1-ton pickups.



634CP

Part No.	Ref. No.	Description
634CP	314750	6" X 34" CHANNEL, 1 1/4" BALL HOLE
638CP	314755	6" X 38" CHANNEL, 1 1/4" BALL HOLE
642CP	314760	6" X 42" CHANNEL, 1 1/4" BALL HOLE
634CS	314765	6" X 34" CHANNEL, 2 3/16" SMOOTH SHANK COLLAR
638CS	314770	6" X 38" CHANNEL, 2 3/16" SMOOTH SHANK COLLAR
642CS	314775	6" X 42" CHANNEL, 2 3/16" SMOOTH SHANK COLLAR

### Gooseneck Hitch Plates

Heavy Duty Gooseneck Plates are economical and offer universal installation.



Part No.	Ref. No.	Ball Size	Plate Size	Rise	Capacity
2516BP	314400	2 5/16"	3/8" X 15" X 40"	N/A	25,000 LBS
2516BP-1R	314425	2 5/16"	3/8" X 13" X 42"	1"	25,000 LBS
GNP	314500	N/A (1 1/4" BALL HOLE)	1/4" X 18 1/4" X 42"	2 1/2"	NR



2516BP-1R

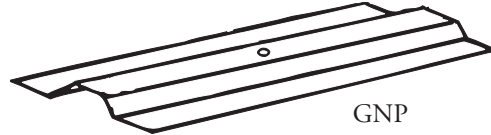

GNP

### Atwood Folding Gooseneck Hitch Ball

Atwood offers a machined 2 5/16" hitch ball that folds down flush with the truck bed when not in use, leaving the bed clear for full utilization. Comes with safety chain tie down loops that work in conjunction with our #SC3835 and #SC71637 Safety Chains.



Part No.	Ref. No.	Description	Ball Size	Plate Size	Capacity
B25CL	314602	FOLDING GN HITCH BALL	2 5/16"	12" X 14"	25,000 LBS



### Wallace Forge Folding Gooseneck Hitch Ball

Wallace Forge offers a drop-forged 2 5/16" hitch ball, a square hitch ball base and door for greater stability, a secondary spring loaded pin for added security when the hitch ball is in use, and safety chain tie downs which provide connections for #SC3835 and #SC71637 Safety Chains. (Safety chains pictured, but not included).



Part No.	Ref. No.	Description	Ball Size	Plate Size	Capacity
WF2516-FB	314610	FOLDING GN HITCH BALL	2 5/16"	12"X14"	25,000 LBS
WF2516-MK2	314617	BOLT ON MOUNTING KIT FOR FOLDING BALL ASSEMBLIES			



## Redline “Pull & Twist” Gooseneck Hitch Ball

The “Pull & Twist” features a unique design where the hitch ball lifts out of its retracting tube with an easy-to-grip handle and locks in place with a spring loaded latch. Due to its symmetrical design the 2 5/16” machined hitch ball mounts in the center of the truck bed. Comes with safety chain tie downs which provide connections for #SC3835 and #SC71637 Clevis Slip Hooks and a magnetic cover to keep debris out of the retracting tube when the hitch ball is not in use.

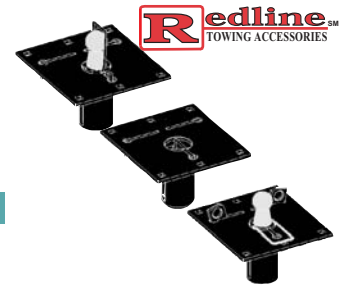

Part No.	Ref. No.	Description	Ball Size	Plate Size	Capacity
PH05000	314620	RETRACTABLE GN HITCH BALL	2 5/16 ”	12”X13”	30,000 LBS
PH05000-CVR	314628	REPLACEMENT MAGNETIC COVER FOR THE #PH05000			

## Redline Gooseneck Hitch Mounting Kits

Vehicle specific mounting kits simplify the installation of most folding ball models. Kits use existing holes in the truck frame for installation and alignment. Rated at 25,000 lbs.

Part No.	Ref. No.	Description
MK6981	313640	FITS 94- PRESENT DODGE PICKUP
MK6986	313642	FITS 80-96 FORD F150
MK6984	313643	FITS 80- PRESENT F250HD/F350/SD
MK6982	313644	FITS 97-00 FORD F150/250LD
MK6983	313646	FITS 99- PRESENT CHEVY NEW BODY
MK6985	313647	FITS 88- 00 CHEV/GMC OLD BODY



## Redline Underbed Hitch

Designed to keep the bed cutout to a minimum, this hitch only requires a 2 1/2” circular hole. The 2 5/16” ball is removable by pulling a remotely mounted cable. Hitch installation requires MK6900 series mounting kit (above) for installation. Rated at 25,000 lbs.

Part No.	Ref. No.	Description
UBH6992	313639	UNDERBED GOOSENECK HITCH CENTER PIECE, REQUIRES MK6900 SERIES KIT SHOWN ABOVE



TOWING  
ACCESSORIES

## B & W Gooseneck Hitch & RV 5th Wheel

The B & W Turnover Ball™ System converts from a towing unit to a level bed in less than 30 seconds. Another much appreciated benefit is the ease of installation. The hitch bolts directly to the frame under the bed using the existing holes already there. Parts listed below ending in “R” include mounting rails. Capacity rated at 30,000 lbs, tongue weight of 7,500 lbs. The RV 5th wheel option is capacity rated at 18,000 lbs, tongue weight of 5,500 lbs.



Part No.	Ref. No.	Description
BW1199R	314630	FOR 99-2001 FORD F250/F350 SUPERDUTY
BW1394R	314632	FOR 94-2001 DODGE 1/2 3/4 1TON PICKUP
BW1061R	314633	FOR 2001 CHEV 3/4 TON HEAVY DUTY
BW1059R	314634	FOR 99-2001 CHEV 1/2 TON SILVERADO
BW1000R	314636	FOR 88-99 CHEV 1/2 3/4 1TON LONG BED
BW1050R	314638	FOR 88-98 CHEVY SHORT BED PICKUP
BW1062R	314639	FOR 2001 CHEVY 1 TON HD
BW1100R	314640	FOR 80-99 FORD 3/4 1TON W/O OVERLOAD SPRINGS
BW1110R	314642	FOR 80-99 FORD 3/4 1T W/ OVERLOAD SPRINGS
BW1150R	314644	FOR 80-96 FORD 1/2 TON PICKUPS
BW1197R	314646	FOR 97-2000 FORD 1/2 3/4TON LIGHT DUTY BODY
BW2050	314668	2 5/16" HI-RISE HITCHBALL OPTION
BW2000	314676	REPLACEMENT 2 5/16" HITCH BALL
BW3000	314700	RV 5TH WHEEL OPTION

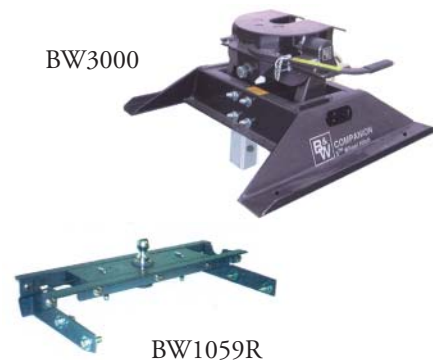

## Hijacker R.V. 5th Wheel & Gooseneck Systems

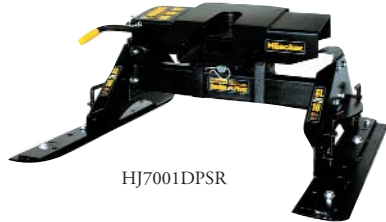

HJ7001DPSR



HJ7025GNSR

One of the highest capacity R.V. 5th Wheels on the market, the Hijacker is available with either a Single or Double pivot head, 16K or 21K capacity, Standard or Slider Mounting Rails. The Single Pivot Head swivels front to back. The Double Pivot head also swivels side to side 7 degrees for easier coupling and uncoupling on uneven ground and smoother, quieter travel. Standard Mounting Rails install *across* the truck bed. Slider Mounting Rails install *along* the truck bed, enabling the 5th Wheel to be repositioned when extra turning room is needed. The Gooseneck Plate utilizes the same Mounting Rails, and includes safety chain tie downs for extra security. Each system can be easily removed from the Mounting Rails to provide full use of the truck bed, and can also be easily upgraded.

Part No.	Ref. No.	Description	Pivot Style	Capacity	Mounting Rails
HJ7001	296700	5th Wheel	Single	16,000 lb	Standard
HJ7001DP	296730	5th Wheel	Double	16,000 lb	Standard
HJ7021DP	296750	5th Wheel	Double	21,000 lb	Standard
HJ7001SR	296800	5th Wheel	Single	16,000 lb	Slider
HJ7001DPSR	296830	5th Wheel	Double	16,000 lb	Slider
HJ7021DPSR	296850	5th Wheel	Double	21,000 lb	Slider
HJ7001USR	296870	5th Wheel	Single	16,000 lb	Slider
HJ7001DPUSR	296875	5th Wheel	Double	16,000 lb	Slider
HJ7025GN	296760	GN Plate	2 5/16" Ball	25,000 lb	Standard
HJ7025GNSR	296860	GN Plate	2 5/16" Ball	25,000 lb	Slider

## Hijacker Installation Mounting Brackets



Seven different mounting brackets are offered for specific types of vehicles, dramatically reducing installation time of the Hijacker systems. All Hijacker 5th Wheel and Gooseneck Hitches come standard with one set (4 ea.) of the #SRU411.

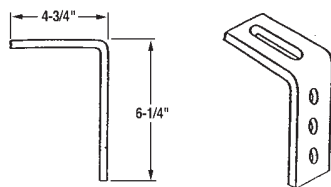

SRU411

Part No.	Ref. No.	Description
SRU411	296900	Universal Bracket, Fits most trucks
SRU411AR	296905	Standard rail brackets, right side, pre '88 Chevy, post '92 Fords
SRU411AL	296906	Standard rail brackets, left side, pre '88 Chevy, post '92 Fords
SRU411B	296910	Standard rail brackets, post '88 Chevy
SRU411C	296915	Slider rail brackets, post '88 Chevy
SRU411D	296920	Slider rail brackets, '97 Ford F150 & F250
SRU411ER	296925	Standard rail brackets, right side, '99 Ford F250 & F350
SRU411EL	296926	Standard rail brackets, left side, '99 Ford F250 & F350

## Holland/Binkley 5th Wheel



For R.V., utility or industrial trailers and accepts standard 2" SAE king pins. The Double Pivot #FW0002-45 permits 10 degree side-to-side pivoting



FW0001

FW6000

Part No.	Ref. No.	Description	Pivot Style	Capacity
FW0001	296200	Binkley 5th wheel, 12" Diameter	Single	32,000 lbs
FW0002-45	296400	Binkley 5th wheel, 12" Diameter	Double	32,000 lbs
FW6000	296600	Holland 5th wheel, 22" Diameter	Single	32,000 lbs

## King Pins

2" SAE King Pins are the standard of the industry and are suitable for use in all over-the-road applications. The Holland Retractable King Pin is to be used with inverted 5th wheel trailers equipped with a #FW0001 or #FW0002-45. Disappears into the truck bed when not in use.



T809

FW0030

Part No.	Ref. No.	Description	Pin Size	Plate Size
T809	297200	Rigid Weld-on	2"	For 3/8" Bolster Plate
FW0030	297400	Holland Retractable	2"	4-Bolt, 14" x 14"



# Body Components

Single Axle Fenders	H-2	Clamp Rings for 90 Degree Windows	H-9
Triple Axle Fender	H-3	90 Degree Radius Windows	H-9
Tandem Fenders	H-3	Vinyl Gravel Guard	H-10
Van Trailer Components	H-4	Aluminum Gravel Guard	H-10
Fender Backs	H-4	Air Conditioner	H-10
Metal Slats	H-5	Two-Speed Electric Fan	H-10
Stock Trailer Side Panels	H-5	Pop-up Ventilators	H-11
Brush Fender Side	H-5	Dome Ventilators	H-11
Van Trailer Roof Cove	H-5	Sloped Ventilator	H-11
Van Trailer Corner Posts	H-5	Butterfly Ventilator	H-11
Running Board	H-6	Lipped Trim	H-12
Ball Corners	H-6	"V" Trim	H-12
Top Bows	H-6	Self Adhesive Trim	H-12
Stock Trailer Pipe Bow	H-6	Chrome Edge Trim	H-12
Nose Bows	H-6	Trim End Cap	H-13
Gussets	H-7	Vinyl Insert	H-13
Low Profile Round Roof Caps	H-7	Insert Trim	H-13
Round Roof Caps	H-7	Drip Rail Trim	H-13
Flat Front Roof Caps	H-7	Flat Trim	H-13
Drop-Down Windows	H-8	Mounting Brackets	H-14
Doors	H-8	Toolboxes	H-14
Uvex Windows and Frames	H-9		

## Single Axle 1" Radius Fenders

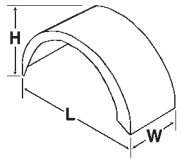

Part No.	Ref. No.	Width	Length	Height	Radius Type	Material	Tire
F55X1925-1R	355420	5.50"	19.25"	6.00"	1", 90° back	16GA	8."
F7X28-1RBS	355440	7.00"	28.00"	9.75"	1" both sides	16GA	13", 14"
F775X28-1R	355460	7.75"	28.00"	9.75"	1", 90° back	16GA	13", 14"
F775X28-1RWB	355470	7.75"	28.00"	9.75"	1", 90° back	16GA	fenderback installed
F9X32-1R	355480	9.00"	32.00"	15.25"	1", 90° back	16GA	14", 15"
F9X32-1RWB	355620	9.00"	32.00"	15.25"	1", 90° back	16GA	fenderback installed
F9X32-1RTP	355640	9.00"	32.00"	15.25"	1", 90° back	14GA treadplate	14", 15"
FSB759X30-1R-RH	355662	7.5" top, 9" bottom	30.00"	15.00"	1", 90° slantback	16GA	14"
FSB759X30-1R-LH	355664	7.5" top, 9" bottom	30.00"	15.00"	1", 90° slantback	16GA	14"
F1075X32-1R	355670	10.75"	32.00"	15.25"	1", 90° back	16GA	14", 15"
F1075X36-1R	355680	10.75"	36.00"	20.25"	1", 90° back	16GA	15", 16"
F13X36-1R	355700	13.00"	36.00"	20.00"	1", 90° back	16GA	16", 16.5"

## Single Axle 2" Radius Fenders



Part No.	Ref. No.	Width	Length	Height	Radius Type	Material	Tire
F7X21-2RBS	355770	7.00"	21"	5.00"	2" both sides	16GA	8", 12"
F75X23-2RBS	355780	7.50"	23"	6.75"	2" both sides	16GA	13", 14"
F9X29-2RBS	355790	9.00"	29"	8.25"	2" both sides	16GA	14", 15"

## Single Axle Poly Fenders

Poly Fenders are popular in the marine industry, and have many other possible applications. Hot-dip galvanized brackets make fender installation a simple job.



Part No.	Ref. No.	Width	Length	Height	Type	Material	Tire
PF775X21W	355300	7.75"	21"	5.25"	Fender	White Poly	8-12"
PF775-BKT	355310	N/A	N/A	N/A	Bracket	galv steel	for fender above
PF11X35W	355320	11.38"	35" (45"OAL)	13"	Fender w/ end steps	White Poly	13-15"
PF1135-BKT	355330	N/A	N/A	N/A	Bracket	galv steel	for fender above

## Single Axle Jeep Style Fenders



Part No.	Ref. No.	Width	Length	Height	Radius Type	Material	Tire
J8824	355825	8"	24.0"	8.00"	1/2" both sides	16GA	8", 12"
J8824AT	355830	8"	24.0"	8.00"	1/2" both sides	ALUM TRDPLT	8", 12"
J101733AT	356420	10"	33.0"	17.00"	1/2" both sides	ALUM TRDPLT	13"- 15"
J101936	356425	10"	36.0"	19.25"	1/2" both sides	16GA	13"- 15"
J10821	356460	10"	21.5"	8.00"	1/2" both sides	16GA	10"

See Page H-4 for precut fender backs

### Tandem Straight, 1" Radius Fender

Part No.	Ref. No.	Width	Length	Height	Radius Type	Material	Tire
FTS9X72-1R	356860	9.00"	72"	20.5"	1", 90° back	16GA	15,16
FTS9X72-1RWB	356880	9.00"	72"	20.5"	1", 90° back	16GA	fenderback installed
FTS9X72-1RTP	356900	9.00"	72"	20.5"	1", 90° back	14GA TREADPLATE	15,16
FTS1075X72-1R	356940	10.75"	72"	20.5"	1", 90° back	16GA	15,16

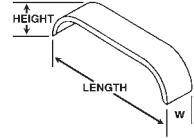

### Tandem Teardrop, 1" Radius Fender

Part No.	Ref. No.	Width	Length	Height	Radius Type	Material	Tire
FTD9X66-1R	357040	9.00"	66"	19.5"	1", 90° back	16GA	14,15
FTD9X72-1R	357060	9.00"	72"	20.5"	1", 90° back	16GA	15,16
FTD9X72-1RWB	357080	9.00"	72"	20.5"	1", 90° back	16GA	fenderback installed
FTD9X72-1RTP	357090	9.00"	72"	20.5"	1", 90° back	14GA TREADPLATE	15,16
FTD9X72-1RA	357100	9.00"	72"	20.5"	1", 90° back	.090 ALUM	15,16
FTD1075X72-1R	357120	10.75"	72"	20.5"	1", 90° back	16GA	15,16
FTD1075X72-1RWB	357140	10.75"	72"	20.5"	1", 90° back	16GA	fenderback installed
FTD1075X72-1RTP	357150	10.75"	72"	20.5"	1", 90° back	14GA TREADPLATE	15,16
FTD1075X72-1RA	357160	10.75"	72"	20.5"	1", 90° back	.090 ALUM	15,16
FTD13X72-1R	357175	13.00"	72"	20.5"	1", 90° back	16GA	15,16



### Tandem Teardrop, 2" Radius Fender

Part No.	Ref. No.	Width	Length	Height	Radius Type	Material	Tire
FTD1075X72-2R	357300	10.75"	72"	20.5"	2", 90° back	14GA	15,16
FTD1075X72-2RA	357320	10.75"	72"	20.5"	2", 90° back	.090 ALUM	15,16
FTD12X72-2R	357340	12.00"	72"	20.5"	2", 90° back	14GA	15,16
FTD12X75-2R	357360	12.00"	75"	22.0"	2", 90° back	14GA	15,16



COMPONENTS  
BODY

### Tandem Jeep Style Fender

Part No.	Ref. No.	Width	Length	Height	Radius Type	Material	Tire
J101969	357625	10"	69"	19"	1/2" both sides	16GA	13-15
J101969AT	357635	10"	69"	19"	1/2" both sides	ALUM TRDPLT	13-15
J101972-TP	357645	10"	72"	19"	1/2" both sides	14GA TRDPLT	15-16



### Triple Axle Fender

Part No.	Ref. No.	Width	Length	Height	Radius Type	Material	Type
FTRD9X108-1R	358800	9.00"	108"	20.5"	1", 90° back	16GA	TEARDROP
FTRD1075X108-1R	359200	10.75"	108"	20.5"	1", 90° back	16GA	TEARDROP

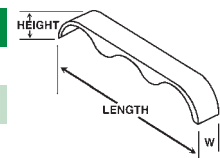

See Page H-4 for precut fender backs

## Fender Backs

Used for additional strength, Fender Backs are available in widths of 10"-12" with or without pre-cut radius to fit inside fenders, made of 16-18 GA material (.048"-.057" thick), 14 GA treadplate also available for tandem fenders.

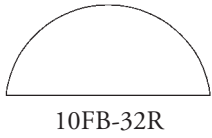

10FB-32R



12FB-72R

Part No.	Ref. No.	Width	Length	Description
10FB	359400	10"	69.00"	RECTANGULAR SHEET
10FB-32R	359500	10.5"	29.75"	PRE-CUT RADIUS, FITS #F9X32-1R FENDERS
12FB-32R	359505	12"	28.75"	PRE-CUT RADIUS, FITS #F9X32-1R FENDERS
12FB	359600	12"	69.00"	RECTANGULAR SHEET
12FB-72R	359650	12"	69.00"	PRE-CUT RADIUS, FITS FENDERS #FTS9X72-1R, FTD9X72-1R, FTS1075X72-1R, FTD1075X72-1R
12FB-72RTP	359675	12"	69.00"	PRECUT RADIUS, FITS FTS9X72-1RTP, FTD9X72-1RTP, FTD1075X72-1RTP
J101972-FB	359680	12"	69.00"	PRECUT RADIUS, FITS J10972-TP

## Van Trailer Ball Corners

Used for many applications in the enclosed trailer industry, these Ball Corners are available in 2 versions, 1 3/4" radius x 5" radius or 1 3/4" radius x 1 3/4" radius.

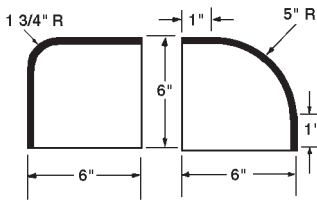

Part No.	Ref. No.	Description
BC1755	347180	1 3/4" RADIUS x 5" RADIUS, 19 GAUGE BALL CORNER
BC175	347190	1 3/4" RADIUS x 1 3/4" RADIUS, 19 GAUGE BALL CORNER

## Van Trailer Roof Caps

Preformed Low Profile 5" radius Caps are available as alternative to the above ball corners, check with your local Redneck representative for additional sizes.

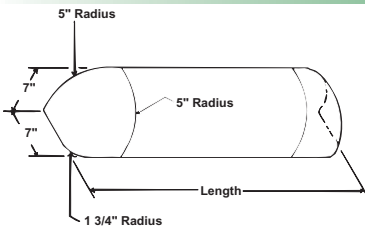

Part No.	Ref. No.	Gauge	Height	Width	Depth	Radius
LPF572	346635	19	7"	72"	7"	1 3/4 x 5

## Van Trailer Hat Bows

The "Hat" shape design, allows for a wider flange to attach the roof and for additional structural strength.

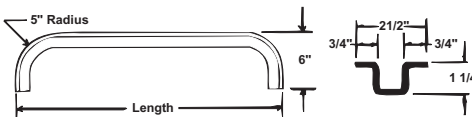

Part No.	Ref. No.	Width	Height	Radius
HTB560	348360	60"	6"	5"
HTB572	348370	72"	6"	5"
HTB584	348380	84"	6"	5"
HTB593	348390	93 1/4"	6"	5"

## Van Trailer Body Side Posts

Also formed in a "Hat" shape for additional strength, side Posts are easy to use and save time in side skin installation.

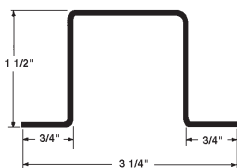

Part No.	Ref. No.	Description
P15-84	349700	1 1/2" DEEP, 3 1/4" WIDE, 84" LONG "HAT" SHAPED BODY POST, 16 GA
P15-96	349710	1 1/2" DEEP, 3 1/4" WIDE, 96" LONG "HAT" SHAPED BODY POST, 16 GA

## Van Trailer Corner Posts

Available in your choice of 2 designs, legs turned in or legs turned out, to work with your frame design. Corner Posts are made of 12 gauge steel.

Part No.	Ref. No.	Description
ICP96	349750	CORNER POST (INSIDE LEGS), 96" LONG
ICP120	349760	CORNER POST (INSIDE LEGS), 120" LONG
OCP96	349765	CORNER POST (OUTSIDE LEGS), 96" LONG

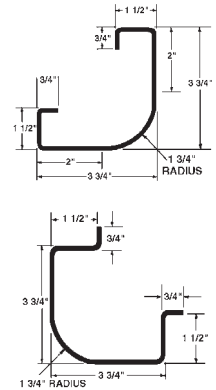

## Van Trailer Roof Cove

Roof Coves feature a 5" radius, are 6 1/2" tall, 6 1/2" wide and made of 12 gauge steel with a drip rail. Available in 96", 120" or 144" lengths.

Part No.	Ref. No.	Description
RC596	349775	ROOF COVE, 5" RADIUS x 96" LONG
RC5120	349780	ROOF COVE, 5" RADIUS x 120" LONG
RC5144	349785	ROOF COVE, 5" RADIUS x 144" LONG

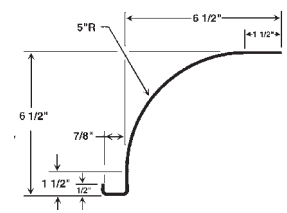

## Brush Fender Side

Brush Fender Side is made of 10 gauge steel and is 10 ft. in length.

Part No.	Ref. No.	Description	Height	Length	Width
STSF110	350600	TRAILER SIDE / FENDER	20"	10'	12"

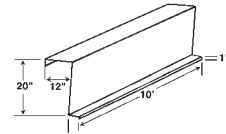

## Stock Trailer Side Panels

Available in 2 heights, 22" and 45", and lengths of 10' and 13', all are 16 gauge. Twenty-two inch Panels have 1 rib, 45" panels have two ribs as shown in diagram.

Part No.	Ref. No.	Height	Length	Gauge
TSD1022	349800	22"	10'	16
TSD1322	350000	22"	13'	16
TSD1045	350200	45"	10'	16
TSD1345	350400	45"	13'	16



BODY COMPONENTS

## Metal Slats

Part No.	Ref. No.	Width	Length	Gauge
MS166	351800	6"	16'	16
MS205.5	352000	5 1/2"	20'	19
MS2065-16GA	352025	6 1/2"	20'	16

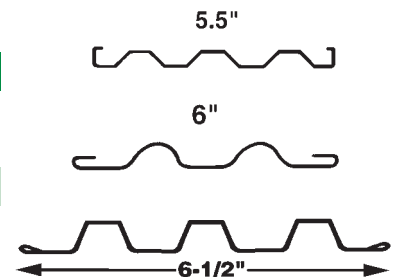

## Running Board

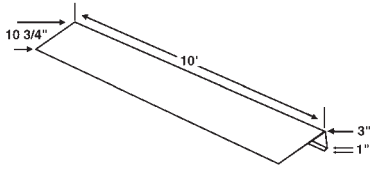

Made of 16 gauge steel, this 10' section allows you to cut your own length.

Part No.	Ref. No.	Description
STRB10	350800	10 3/4" RUNNING BOARD FOR FENDER STYLE STOCK TRAILER

## Nose Bows

Nose Bows are available in 1/8" angle, (1 1/4" x 1 1/4"), or 16 gauge 1" square tubing.

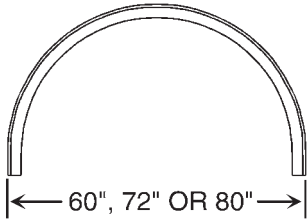

Part No.	Ref. No.	Description
ANB60	348000	60" ROLLED NOSE BOW, 1 1/4" ANGLE
TNB60	348100	60" ROLLED NOSE BOW, 1" SQUARE TUBING
ANB72	348200	72" ROLLED NOSE BOW, 1 1/4" ANGLE
TNB72	348210	72" ROLLED NOSE BOW, 1" SQUARE TUBING
ANB80	348220	80" ROLLED NOSE BOW, 40.5" DEEP, 1 1/4" ANGLE

## Stock Trailer Pipe Bow

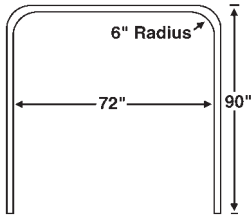

This one-piece bow, made of 1 5/8" O.D. pipe, serves as roof bow and side post combined.

Part No.	Ref. No.	Description
TPB67290	349690	PIPE BOW, 6" RADIUS, 72" WIDE (INSIDE), 90" TALL

## Top Bows

Top Bows are 16 gauge 1" square tubing.

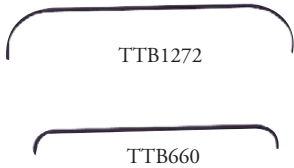

Part No.	Ref. No.	Width	Height	Radius
TTB660	348400	60"	7"	6"
TTB672	348600	72"	7"	6"
TTB680	348650	80"	7"	6"
TTB684	348800	84"	7"	6"
TTB1260	349200	60"	14"	12"
TTB1272	349400	72"	14"	12"
TTB1280	349450	80"	14"	12"
TTB1284	349600	84"	14"	12"

## Ball Corners

Ball Corners are available in aluminum or steel.

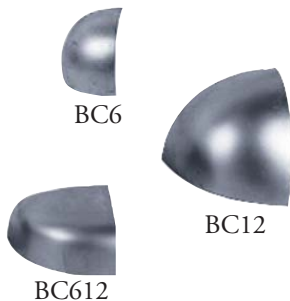

Part No.	Ref. No.	Description	Material
BC6	347200	6" RADIUS BALL CORNER CAP	19GASTEEL
BC6A	347250	6" RADIUS BALL CORNER CAP	.050 ALUM
BC8	347300	8" RADIUS BALL CORNER CAP	19GASTEEL
BC12	347400	12" RADIUS BALL CORNER CAP	19GASTEEL
BC612	347600	6" x 12" RADIUS COMBINATION CORNER CAP	19GASTEEL
BC612A	347650	6" x 12" RADIUS COMBINATION CORNER CAP	.050 ALUM



## Flat Front Roof Caps

- Available in widths of 60", 72" and 84"
- Available in 6" (Low Profile) or 12" radius designs

Part No.	Ref. No.	Gauge	Height	Width	Depth	Radius
F1272	346400	19	13"	72"	13"	12"
LPF660	346800	19	8"	60"	8"	6"
LPF672	347000	19	8"	72"	8"	6"
LPF680	347050	19	8"	80"	8"	6"
LPF684	347100	19	8"	84"	8"	6"



LPF672

## Round Roof Caps

Industry standard for years, Round Roof Caps are available in 3 sizes.

Part No.	Ref. No.	Gauge	Width	Height	Depth	Radius
R1260	345200	19	60" (2 PC)	15"	37"	12"
R1272	345400	19	72" (2 PC)	15"	37"	12"
R1280	345425	18	80" SEMI-RD	14"	36"	12"



R1260

## Low Profile Round Roof Caps

Low Profile Roof Caps are a 6" radius, available in 60", 72" and 80" widths.

Part No.	Ref. No.	Gauge	Width	Height	Depth	Radius
LPR660	345600	19	60"	8"	35"	6"
LPR672CB	346200	18	72"	8"	37"	6"
LPR672	346210	18	72"	8"	37"	6"
LPR680	346220	18	80" SEMI-RD	8"	36"	6"



LPR672CB

BODY COMPONENTS

## Gussets

Gussets provide an important part of the strength and design of every trailer. We have 3 sizes of Gooseneck Gussets available, with or without a lip. Rear Tail Light Gussets serve two purposes: 1. To stabilize and strengthen the trailer sides and 2. To serve as a mounting place for the tail lights. (Tail Light Gussets are made of 14 gauge metal.)

Part No.	Ref. No.	Description
1515G	359700	15" x 15" x 3/16" WITH 1" LIP
1534GL	359705	15" x 34" x 3/16" WITH 1" LIP, LEFT HAND
1534GR	359710	15" x 34" x 3/16" WITH 1" LIP, RIGHT HAND
2424G	359715	24" x 24" x 1/4" WITHOUT LIP
LHRG10	359720	10" x 46" WITH 1" LIP, LEFT HAND WITH 4 1/2" DIA. LIGHT CUT-OUT
RHRG10	359725	10" x 46" WITH 1" LIP, RIGHT HAND WITH 4 1/2" DIA. LIGHT CUT-OUT



1534GR



LHRG10 & RHRG10

Section H-7

## Feed Doors



RFD-2

Feed Doors are rolled, hemmed and have an installed hinge. Feed Doors measure 23 1/2" wide x 19" tall.

Part No.	Ref. No.	Description	Gauge
RFD-2	352200	ROLLED WITH HEM AND HINGE	16

## Saddle Doors



SD-4

Saddle Doors are rolled, hemmed and hinged. Available with or without a cut-out for flush latch. Both Saddle Doors measure 29 1/2" wide x 33" tall.

Part No.	Ref. No.	Description	Gauge
SD-3	352600	ROLLED SADDLE DOOR WITH HEM AND HINGE	16
SD-4	352800	ROLLED SADDLE DOOR WITH HEM, HINGE AND 2 3/4" x 3 3/4" FLUSH LOCK CUT-OUT	16

## Escape Doors



ESD-3

Save time and money by utilizing our pre-fabricated Escape Doors! All Escape Doors are flat with reinforcing ribs and have a 2 3/4" x 3 3/4" hole cut-out for installing the junior size flush latch of your choice. All Escape Doors are hinged.

Part No.	Ref. No.	Description	Gauge
ESD-3	353000	21" WIDE x 35 3/8" TALL	16
ESD-4	353200	21" WIDE x 45 1/2" TALL	16
ESD-5	353400	29 1/2" WIDE x 59" TALL	16

## Camper Doors



2460CD

Our Camper Doors are constructed of rugged fiberglass bonded firmly to a solid foam core with a 12" x 27" vertical sliding window for effective ventilation. Each door has a heavy-duty reinforced full interior aluminum screen door with a latch attachment to allow the option for the screen door to open with the primary door. All doors open from the left with hinges on the right. Camper Doors have a weathertight seal, quiet operation and secure closing. All sizes are key locking with a flush mount latch. Measurements shown are rough opening sizes.

Part No.	Ref. No.	Cut-out Size
2460CD	353600	24" x 60"
2464CD	353800	24" x 64"
2468CD	354000	24" x 68"
2868CD	354200	28" x 68"
3060CD	354400	30" x 60"
3066CD	354500	30" x 66"
3068CD	354600	30" x 68"
3660CD	354800	36" x 60"
3664CD	355000	36" x 64"
3668CD	355200	36" x 68"
CDLAT	355250	REPLACEMENT DOOR LATCH ASSEMBLY W/KEY

## Drop-Down Windows



Drop-Door Windows serve as "feed-door" and window combined! Top-latch handle opens from outside, hinged at bottom. "T-slider" style lower glass panel allows screened ventilation with window in upright-closed position. (Add 1/4" to window size for rough opening dimension.)

Part No.	Ref. No.	Description
SG2024DD	371705	20" X 24", FITS LEFT OR RIGHT SIDE
SG2030DD	371715	20" X 30", FITS LEFT OR RIGHT SIDE
SG2430DD	371725	24" X 30", FITS LEFT OR RIGHT SIDE

## 90 Degree Radius Windows

90 Degree Radius Windows come standard with tempered safety glass, black frames and inside screens. They have an inside latch and outside pull handles, and are designed to fit either the left or right hand side. We have selected 7 popular sizes to fit your applications (add 1/4" to window size for rough opening dimension).

Part No.	Ref. No.	Description
SG1218	368300	12" x 18", FITS LEFT OR RIGHT SIDE
SG1224	368417	12" x 24", FITS LEFT OR RIGHT SIDE
SG1236	368422	12" x 36" FITS LEFT OR RIGHT SIDE
SG1242	368440	12" x 42", FITS LEFT OR RIGHT SIDE
SG1248	368452	12" x 48", FITS LEFT OR RIGHT SIDE
SG1524	368470	15" x 24", FITS LEFT OR RIGHT SIDE
SG1842	368550	18" x 42", FITS LEFT OR RIGHT SIDE

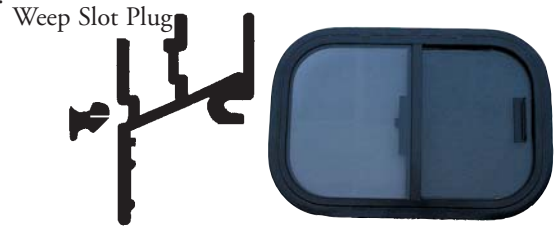

Note: After window has been installed, remove all weep slot plugs from the bottom of the window. Not removing bottom weep slot plugs will result in leaking windows.

## Clamp Rings for 90 Degree Windows

Although most trailer windows are attached by rivets or screws, we also offer clamp rings for fast, neat installation. Choose clamp rings by wall thickness and window size. No. 8 x 1/2" screws (not included) are recommended for proper installation. Listed below are clamp rings for our 90 degree windows and 3/4" or 1 1/4" wall thickness. Others are available by special request.

Part No.	Ref. No.	Description	Fits Window No.	Wall Thickness
SG1218CR006	368310	90 DEGREE CLAMP RING	SG1218	3/4"
SG1218CR012	368315	90 DEGREE CLAMP RING	SG1218	1 1/4"
SG1224CR006	368418	90 DEGREE CLAMP RING	SG1224	3/4"
SG1224CR012	368419	90 DEGREE CLAMP RING	SG1224	1 1/4"
SG1236CR006	368426	90 DEGREE CLAMP RING	SG1236	3/4"
SG1236CR012	368429	90 DEGREE CLAMP RING	SG1236	1 1/4"
SG1242CR006	368442	90 DEGREE CLAMP RING	SG1242	3/4"
SG1242CR012	368444	90 DEGREE CLAMP RING	SG1242	1 1/4"
SG1248CR006	368456	90 DEGREE CLAMP RING	SG1248	3/4"
SG1248CR012	368459	90 DEGREE CLAMP RING	SG1248	1 1/4"
SG1524CR006	368472	90 DEGREE CLAMP RING	SG1524	3/4"
SG1524CR012	368474	90 DEGREE CLAMP RING	SG1524	1 1/4"
SG1842CR006	368552	90 DEGREE CLAMP RING	SG1842	3/4"
SG1842CR012	368554	90 DEGREE CLAMP RING	SG1842	1 1/4"

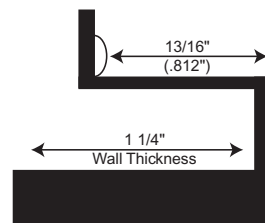
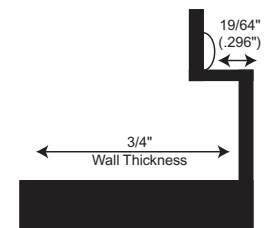

COMPONENTS  
BODY

## Uvex Windows and Frames

Uvex is preferred by many trailer builders because it is impact and weather resistant and easy to form. It comes in an attractive smoke color, which shields the interior from the sun while allowing ample light and an open view of the outdoors. Use 1923-12 trim (pg H-12) as a frame for rectangular or rubber gasket (sold below), for installation of oval windows.

Rectangular				
Part No.	Ref. No.	Size	Description	Color
815UVS	365000	8"x15"	WINDOW	SMOKE
818UVS	365600	8"x18"	WINDOW	SMOKE
920UVS	366200	9" x 20"	WINDOW	SMOKE
Oval				
Part No.	Ref. No.	Size	Description	Color
818UVSR	365620	8"x18"	RADIUS WINDOW	SMOKE
920UVSR	366220	9" x 20"	RADIUS WINDOW	SMOKE
RG1816	366480	50' ROLL	RUBBER GASKET FOR 1/8" U-VEX WINDOWS, FITS 16 GA METAL	BLACK



Rectangular

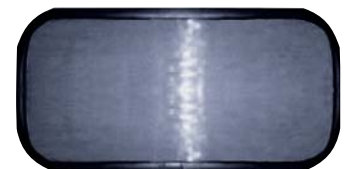

Oval

## Two-Speed Electric Fan



- Use in trucks, trailer dressing rooms and cargo areas
- Built-in switch and ball swivel base
- High/Low speed operation for ventilating, circulating, etc.
- Includes pig-tail wires and mounting gaskets
- Complete & ready to install

Part No.	Ref. No.	Description
175-14	372700	12 VOLT, 2 SPEED FAN WITH SWIVEL BASE

## Air Conditioner

**Coleman-Mach**  
RV Air Conditioners



- Proven performer in the RV industry
- 13,500 BTU or 14,800 BTU, 115 volt/60HZ
- 2-Speed fan w/temperature control
- Optional 5,600 BTUH Heat Strip

Coleman Mach (two-speed rotary) Air Conditioners will add cooling comfort to Horse/Stock trailer dressing rooms, race car trailers, and portable offices. The 320CFM air flow will provide comfortable temperatures quickly and efficiently, even in the most searing heat wave. Requires a 14" x 14" roof opening for installation. Power Cord and Hatch sold separately.

Part No.	Ref. No.	Description
TSR135	372780	13,500 BTU A/C UNIT W/2-SPEED FAN
TSR150	372781	14,800 BTU A/C UNIT W/2-SPEED FAN
TSR135H	372785	13,500 BTU A/C UNIT W/2-SPEED FAN & HEAT STRIP
TSR150H	372784	14,800 BTU A/C UNIT W/2-SPEED FAN & HEAT STRIP
PC3030	372787	AIR CONDITIONER POWER CORD, 30 AMP, 30 FT LONG
PCH656	372790	AIR CONDITIONER POWER CORD HATCH W/LOCK, 6 1/2" X 6" (4 3/4" X 4 1/4" HOLE) PAINTABLE, WHITE

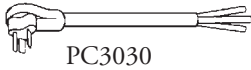

PC3030

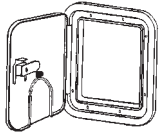

PCH656

## Aluminum Gravel Guard



Brushed Aluminum Gravel Guard with a diamond design is sold by the foot or in 250 ft. rolls.

Part No.	Ref. No.	Description	Width
GG9	364200	GRAVEL GUARD	9"
GG12	364400	GRAVEL GUARD	12"
GG14	364600	GRAVEL GUARD	14"
GG18	364800	GRAVEL GUARD	18"

## Vinyl Gravel Guard



Used as an alternative to Aluminum, the Vinyl Gravel Guard is sold by the foot or in 150 ft. rolls.

Part No.	Ref. No.	Description	Width
VGG9	364825	BLACK ADHESIVE-BACK VINYL GRAVEL GUARD	9"
VGG12	364850	BLACK ADHESIVE-BACK VINYL GRAVEL GUARD	12"
VGG18	364860	BLACK ADHESIVE-BACK VINYL GRAVEL GUARD	18"

## Butterfly Ventilator

A full 7 1/2" in diameter, the Polished Aluminum Ventilator is an attractive and useful source of ventilation. For horse, stock, dog or various other types of trailers.

Part No.	Ref. No.	Description
775	371800	ROUND POLISHED ALUMINUM VENT, 7 1/2" DIAMETER



## Sloped Ventilator

Two-piece Ventilator comes with; roof mount sloped roof vent, gasket & interior butterfly vent.

Part No.	Ref. No.	Description
9139	372400	SLOPED METAL ROOF VENT 10" x 12", WITH VENT AND GASKET



## Dome Ventilators

Dome Crank-out Vents with screen and inside trim can double as a vent and a skylight. Available with a variety of options, all vents come with inner trim garnish.

Part No.	Ref. No.	Description
M1659	372600	14" X 14" DOME VENT W/WHITE ACRYLIC TOP
M1659-12V	372610	14" X 14" DOME VENT W/WHITE ACRYLIC TOP & 12 VOLT FAN
M1660	372625	14" X 14" DOME VENT W/GALV METAL TOP
V554	372630	REP'L 14" X 14" WHITE ACRYLIC TOP FOR M1659, M1659-12V
V2047	372650	22" X 22" "ESCAPE HATCH" DOME VENT W/WHITE ACRYLIC TOP



BODY  
COMPONENTS

## Pop-up Ventilators

Offers simple lever operation, a wide flange for installation and a large opening for maximum air flow. The screen prevents objects from entering trailer. Inner Trim Garnish Available.

Part No.	Ref. No.	Description
9106	372000	TWO-WAY POP-UP VENTILATOR WITH SCREEN, 8" x 12", AND MOUNTING GASKET
9106AL	372020	TWO-WAY ALUMINUM POP-UP VENTILATOR WITH SCREEN, 8" X 12", AND MOUNTING GASKET
2756	372100	INNER TRIM GARNISH FOR 9106, 9106AL BLACK PLASTIC, 2 1/4" TALL (CAN EASILY BE CUT TO FIT PROPER DEPTH OF CEILING)



2756 trim garnish shown installed with 9106 ventilator

## Chrome Edge Trim



This flexible plastic molding has a permanent chrome finish, and is easy to cut and install. It fits up to 1/8" thick material, and has a pressure-sensitive adhesive in the interior channel to insure a permanent installation.

Part No.	Ref. No.	Description
SAT012ET	364050	CHROME EDGE TRIM, FITS UP TO 1/8" WIDE MATERIAL, 50 FT.ROLL

## Self Adhesive Trim

- Flexible, Faster Installation
- Labor Saving, Self Adhesive Tape
- UV Resistant, Water Spot Resistant
- Cost effective rolls-cut & use as needed



Part No.	Ref. No.	Description	Width	Length
SAT060DR	364055	DRIP RAIL, CHROME	.60"	50'ROLL
SAT075C	364060	FLAT, CHROME	.75"	100'ROLL
SAT100C	364065	FLAT, CHROME	1.00"	100'ROLL
SAT125C	364070	FLAT, CHROME	1.25"	100'ROLL
SAT137CBK	364075	CHROME W/ COLOR INSET, BLACK	1.379"	100' ROLL
SAT137CWE	364080	CHROME W/ COLOR INSET, WHITE	1.379"	100'ROLL
SAT137CRD	364085	CHROME W/ COLOR INSET, RED	1.379"	100'ROLL
SAT137CSL	364090	CHROME W/ COLOR INSET, SILVER	1.379"	100' ROLL
SAT525BK	364100	BLACK STEPTREAD	5.25"	50'ROLL

## "V" Trim

Aluminum V Trim is used throughout the horse and stock trailer industry to give that "extra" touch to the front of the trailer. It can be easily worked to create special effects.



Part No.	Ref. No.	Description	Width	Length
49VS-12	361000	"V" CHROME TRIM	1 1/8"	12'

## Lipped Trim

Available in 1", 1 1/4" or 1 5/8" width, Lipped Trim is designed to be used as a decorative trim to cover the unfinished edges of a lapped joint.



Part No.	Ref. No.	Description	Width	Length
1923-12	362200	ALUMINUM TRIM	1"	12'
1924-12	362400	ALUMINUM TRIM	1 1/4"	12'
2625-12	362800	ALUMINUM TRIM	1 5/8"	12'

## Flat Trim

Used as a seam covering, this Flat Trim is 3/4" wide and 12' in length.

Part No.	Ref. No.	Description	Width	Length
213-12	362000	FLAT ALUMINUM TRIM	3/4"	12'



## Drip Rail Trim

Drip Rail Trim is used over openings and doors to channel water away from the opening. It is available in 3/4" or 1 1/4" widths.

Part No.	Ref. No.	Description	Width	Length
688-12	361200	DRIP RAIL, ALUMINUM	3/4"	12'
788-12	361400	DRIP RAIL, ALUMINUM	1 1/4"	12'

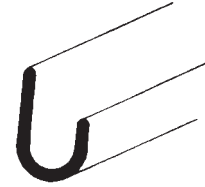

## Insert Trim

Insert Trim is used in many different ways to color coordinate trailers. It can also be used to cover lapped joints and flat seams. Used with any of the 5 colors of vinyl insert, this trim adds a nice touch to any trailer.

Part No.	Ref. No.	Description	Width	Length
1904-12	361600	UNEVEN LIP, ALUMINUM	1 3/16"	12'
2605-12	361800	EVEN LIP, ALUMINUM	1 1/4"	12'

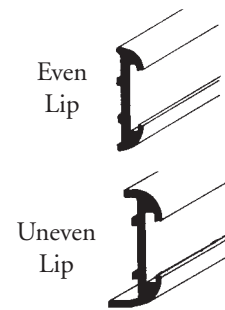

## Vinyl Insert

Use this Vinyl Insert with 1904, 2605 trim. Sold by the roll (1,000') or by the foot.

Part No.	Ref. No.	Description	Width	Length
CT8BK	363200	BLACK VINYL INSERT	1"	CUT TO LENGTH
CT8SL	363700	SILVER/ALUMINUM VINYL INSERT	1"	CUT TO LENGTH
CT8WE	363800	WHITE VINYL INSERT	1"	CUT TO LENGTH

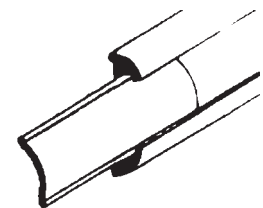

## Trim End Cap

Used to finish the end of 2605 or 1904 Series Insert Trim, this Aluminum Cap protects the trim and insert from damage.

Part No.	Ref. No.	Description
E2605CE	364000	END CAP FOR 1904, 2605 INSERT TRIM

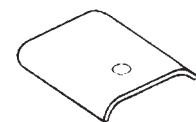

### Underbody Toolboxes



The original Redline Toolbox, this heavy duty box is constructed of 13 gauge steel. A powder coat finish, stainless steel T-handle and neoprene door seal give this box years of rugged use.

Part No.	Ref. No.	Length	Height	Depth
UB1416-24	350900	24"	14"	16"
UB1818-24	350920	24"	18"	18"
UB1818-30	350930	30"	18"	18"
UB1818-36	350940	36"	18"	18"
UB1818-48	350960	48"	18"	18"

### Aluminum Underbody Toolboxes



Designed to complement aluminum trailers and truck beds, these durable boxes are constructed of .100" aluminum treadplate. The stainless steel T-latch and hinge, combined with an automotive grade door seal keep this attractive box in use for many years.

Part No.	Ref. No.	Length	Height	Depth
ALUB1818-24	350860	24"	18"	18"
ALUB1818-30	350862	30"	18"	18"
ALUB1818-36	350864	36"	18"	18"
ALUB1818-48	350866	48"	18"	18"

### Mounting Brackets

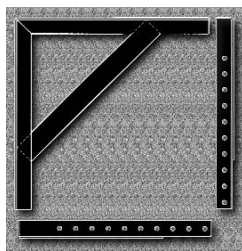

For mounting underbody toolboxes to truck or trailer frames. These brackets are pre-drilled for convenient attachment. Constructed of 7 gauge steel, brackets are powder coated to prevent corrosion.

Part No.	Ref. No.	Description
UB-BRACKET	350998	INSTALLATION BRACKET

### A-Frame Toolboxes



Ideal for the front of cargo, horse and utility trailers, A-Frame boxes are constructed of 14 gauge steel, feature a stainless steel latch and a gas prop to hold the lid in the open position. Powder coated finish to protect against corrosion.

Part No.	Ref. No.	Depth	Height	Width
TB1414-30	350980	14"	14"	30"
TB1620-36	350990	16"	20"	36"





# Chemicals and Coating

## Product Index:

Sealants	I-2
Spray-on Undercoating	I-2
Brake Fluid	I-2
Heavy Duty Wheel Bearing Grease	I-2
WD-40	I-2
Custom Pinstripe Tape	I-3
Pin Stripers	I-3
Resealable Paint Can Lid	I-3
Weather Strip Tape	I-3
Warning and Specification Decals	I-4
Primer	I-4
Metal Surface Cleaner	I-4
Hardener	I-5
Enhancer	I-5
Reducer	I-5
Valspar Supreme Acrylic Enamel	I-7
Valspar Trailglo Enamel	I-7

## How-To Section Index

Trailglo or Supreme?	I-6
Differences Between Trailglo Enamel and Supreme Acrylic	I-6
Instructions For Application of Metal Surface Cleaner	I-8
Painting Tips	I-8

## WD-40



WD-40 cleans and protects metal and displaces moisture. It is designed to stop squeaks and to loosen rusted parts.

Part No.	Ref. No.	Description	Size
40-1	392800	WD-40 Bulk	1 Gal
SU-1	393000	Spray Applicator, Refillable Bottle	1 Qt. Bottle

## Heavy Duty Wheel Bearing Grease



Designed to provide excellent shear resistance, this Wheel Bearing Grease fights high temperature run-out and caking, and is highly water resistant. It is recommended for heavy-duty bearing applications that include extreme pressure and high temperatures.

Part No.	Ref. No.	Description	Size
4050-T	392000	Grease Cartridge	14 oz.
4050-1	392200	Grease Tub	1 lb.
4050-4	392400	Grease Tub	4 lb.

## Brake Fluid



Recommended for all types of brake systems (drum and disc brakes), this Brake Fluid mixes with all brake fluids approved by car, truck, tractor and bus manufacturers. Meets or exceeds DOT-3 specifications.

Part No.	Ref. No.	Description	Size
BF1QT	391600	Brake Fluid	1 qt.
BF1G	391800	Brake Fluid	1 gal.

## Spray-on Undercoating



A spray-on undercoating protects metal from corrosion and abrasion; helps prevent rusting, reverse dimpling of wheel wells and fenders; provides a sound-dampening coating on door skins; helps keep paint from chipping and peeling – can be used as "spray-on" gravel guard. Application of undercoating is convenient and easily applied to hard to reach places such as undercarriages, wheel wells and fenders.

Part No.	Ref. No.	Description	Size
737	391400	Spray-on rubberized undercoating	18 oz. can

## Sealants



"SCS" Silicone Sealant can be used for permanent, water-tight bonds and will not crack, mildew or shrink. It can be used with glass, ceramic, steel, and most plastics. Part #2300 is a paintable sealant that works on all surfaces, including aluminum.

Part No.	Ref. No.	Color	Size
2300	389991	Clear	10.3 oz
SCS1001	390000	Clear	10.3 oz
SCS1002	390200	White	10.3 oz
SCS1009	390300	Silver / Aluminum	10.3 oz

## Weather Strip Tape

Easy to cut and apply, this Weather Strip Tape has a self-adhesive back and is compatible with all types of Silicone Sealants. It will withstand a high level of movement and will conform to irregular surfaces. It resists cracking, is durable and long-lasting.

Part No.	Ref. No.	Size	Ft per Roll
WS1838	390400	1/8" x 3/8" wide	100 ft
WS1812	390600	1/8" x 1/2" wide	100 ft
WS1834	390800	1/8" x 3/4" wide	100 ft
WS1412	391000	1/4" x 1/2" wide	45 ft
WS1434	391200	1/4" x 3/4" wide	45 ft



WS1838

## Resealable Paint Can Lid

Designed for storage of our 5 gallon paint, this Resealable Paint Can Lid consists of a metal ring and flat top set with a foam gasket ring to provide a tight seal.

Part No.	Ref. No.	Description	Size
RSLD-5	360943	Resealable lid for paint containers	5 gal

## Pin Stripers

A Pin Striper with guides is recommended when a perfect stripe is needed -- decorative striping, identification marking or application of adhesive materials. Pin strippers will stripe in many positions and will produce a wide variety of stripes.

Part No.	Ref. No.	Description	Size Heads
1004	493700	Single line gravity fed	1/16"
CRAFT-2	493800	Craftsman model w/ 2 heads	1/16" & 1/32"
DELUXE-3	494000	Deluxe Model w/ 3 heads	3/32", 1/32" & 7/64"



DELUXE-3



1004

## Custom Pinstripe Tape

3 1/8"  
Tape

1 1/8"  
Tape



Pinstriping has long been the final touch to horse/stock and van trailers, usually by use of a hand-held paint striper. While commonly accepted, it limits the type of striping possible. Custom, multi-stripe pinstriping is available from Redneck in 4 colors and 2 widths. This 5-stripe tape can be easily applied to any trailer, creating a high quality professional appearance in minutes.

Part No.	Ref. No.	Color	Width	Length
76310	360990	Burgandy	1 1/8"	150 ft roll
76302	360992	Black	1 1/8"	150 ft roll
76305	360993	Silver Metallic	1 1/8"	150 ft roll
76356	360994	Bright White	1 1/8"	150 ft roll
76410	360995	Burgandy	3 1/8"	50 ft roll
76402	360996	Black	3 1/8"	50 ft roll
76405	360997	Silver Metallic	3 1/8"	50 ft roll
76456	360999	Bright White	3 1/8"	50 ft roll



Turn Plain...

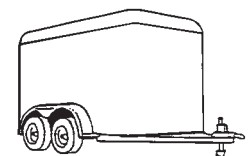

Into Custom!

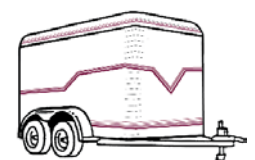

## Warning and Specification Decals

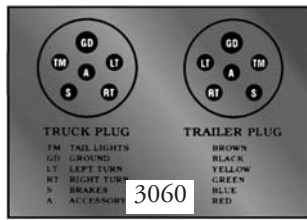

3060

### CHECK BEFORE TOWING:

- ALL PARTS, BOLTS AND NUTS ARE TIGHT
- LOAD IS PROPERLY SECURED IN ON TRAILER.
- TIRES PROPERLY INFLATED.
- TRAILER IS NOT OVERLOADED.
- ELECTRICAL CONNECTIONS ARE WORKING.
- BRAKES ARE WORKING PROPERLY.
- THE SAFETY CHAIN IS SECURED.
- THE LATCHING MECHANISMS ARE SECURE.
- ALL GATES ARE SECURED.
- THE JACK IS RAISED TO ITS HIGHEST POSITION.
- THE CRANK HANDLE IS SECURED.

IT PAYS TO BE SAFE!

3010

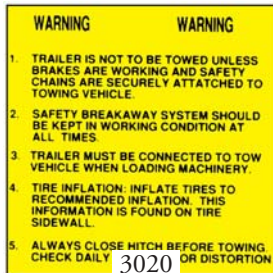

3020

Part No.	Ref. No.	Description	Dimensions
3001	414025	WARNING DECAL: DO NOT EXCEED...	2 7/16" x 3 1/2"
3010	414050	WARNING DECAL: CHECK BEFORE TOWING...	2 7/8" x 2 7/8"
3020	414075	WARNING DECAL: TRAILER NOT TO BE...	2 7/8" x 2 7/8"
3030	414100	WARNING DECAL: CHECK WHEEL LUG...	2" x 2"
3040	414125	WARNING DECAL: SECURE ALL GATES...	2 7/16" x 3 1/2"
3050	414150	WARNING DECAL: SAFETY BREAKAWAY...	2 7/16" x 3 1/2"
3060	414175	SPEC DECAL: WIRING DIAGRAM FOR 6....	2 7/16" x 3 1/2"



3030



3001

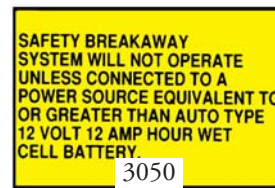

3050



3040

## Metal Surface Cleaner



The most important step of any paint application is surface preparation. The surface must be clean and free of dirt, surface rust or oils. As high as 70% of all coating failures can be directly attributed to inadequate surface preparation. To aid you in surface preparation, Redneck offers a metal surface cleaner that is compatible with our paint system. Metal Surface Cleaner comes in a 1-gallon "concentrated" form. Use it "full strength" for those tough surfaces, or dilute it (1 gallon concentrate to 4 gallons water) for general surface cleaning.

Part No.	Ref. No.	Description	Size
300C001	360963	Metal Surface Cleaner, Conentrate	1 gal

## Primer

Primer is a must for the proper paint job! Our non-sanding Primer provides a better surface for the paint to adhere to, filling minor surface irregularities. It also improves rust and corrosion resistance.

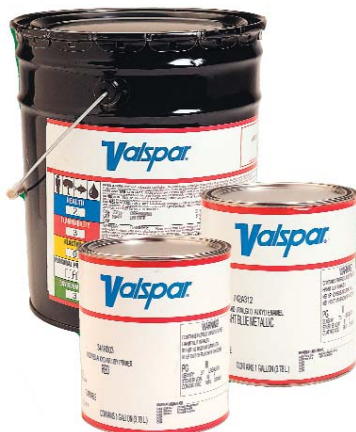

Valspar Trailglo			
Part No.	Ref. No.	Color	Size
341X003-1	360933	Gray	1 gal
341X003-5	360934	Gray	5 gal
341R003-1	360935	Red	1 gal
341R003-5	360936	Red	5 gal
Valspar Supreme			
341X017-1	360601	Gray	1 gal
341X017-5	360602	Gray	5 gal



## Reducer

Reducer is used to thin Paint or Primer to a viscosity that will allow proper spraying. The most effective Reducer to be used depends on the temperature in the area where a product is being sprayed. We offer three Reducers for various temperature ranges.

Valspar Trailglo				
Part No.	Ref. No.	Type	Temp. Range	Size
DER85-100-1	360944	Slow Reducer	85° - 100°	1 gal
DER85-100-5	360946	Slow Reducer	85° - 100°	5 gal
DER65-90-1	360949	Medium Reducer	65° - 95°	1 gal
DER65-90-5	360951	Medium Reducer	65° - 95°	5 gal
DER45-75-1	360954	Fast Reducer	45° - 75°	1 gal
DER45-75-5	360956	Fast Reducer	45° - 75°	5 gal
Valspar Supreme				
DAR85-100-1	360651	Slow Reducer	85°-100°	1 gal
DAR85-100-5	360652	Slow Reducer	85°-100°	5 gal
DAR65-90-1	360653	Medium Reducer	65°-90°	1 gal
DAR65-90-5	360654	Medium Reducer	65°-90°	5 gal
DAR45-75-1	360655	Fast Reducer	45°-75°	1 gal
DAR45-75-5	360656	Fast Reducer	45°-75°	5 gal

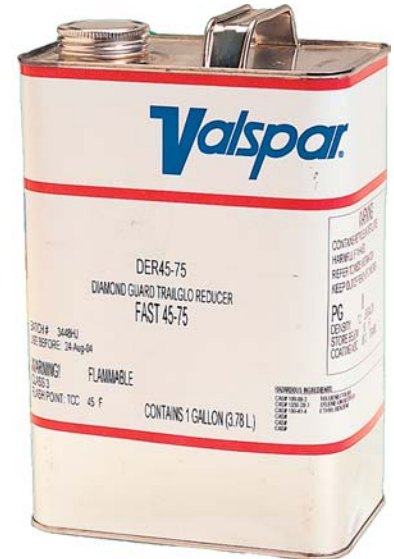

## Enhancer

Gloss Enhancer improves gloss, reduces water spots and improves the long term durability of Trailglo enamels. This additive is for use in less than ideal application conditions, such as high humidity or cold weather. When Gloss Enhancer is added to Trailglo, the paint has an unlimited pot life. **Only use with Trailglo enamels.**

Part No.	Ref. No.	Description	Size
665C001	360961	Gloss enhancer	1 quart



CHEMICALS  
& COATING

## Hardener

Hardener is designed to increase gloss retention. It improves surface resistance to chips, chemicals, marring, water spotting and wrinkling. Hardener also speeds production by reducing tack-free and recoat times.

Part No.	Ref. No.	Description	Size
699C333	360959	Enamel hardener for Trailglo	1 quart
699C900	360701	Acrylic enamel hardener for Supreme	1 quart



## Trailglo or Supreme?

What type of trailer and what is the paint need?	Trailglo Enamel	Supreme Acrylic
Small utility/flatbed gooseneck trailer using local or inexpensive paint?	Yes	
Small utility/flatbed gooseneck trailer being built as cheap as possible?	Yes	
Small utility/flatbed gooseneck trailer wanting higher quality paint finish?		Yes
Small utility/flatbed gooseneck trailer using an acrylic enamel?	Yes	Yes
Horse/stock trailer using local or inexpensive paint?	Yes	
Horse/stock trailer using local or inexpensive paint wanting higher quality paint?		Yes
Horse/stock trailer using refinish coatings from local jobber?		Yes
Horse/stock trailer wanting the best paint available without using urethane paints?		Yes



## Differences Between Trailglo Enamel and Supreme Acrylic

APPLICATION INFORMATION	TRAILGLO ENAMEL	SUPREME ACRYLIC
MAY BE USED WITHOUT PRIMER:	Yes over clean steel (No warranty)	Not Recommended
VALSPAR PRIMER USED:	341X003 Gray or 341R003 Red. 341X017 Gray may be used for higher quality primer	341X017 Gray is recommended. 341X/R003 may be used but with poorer corrosion protection
REASON FOR DIFFERENT PRIMERS:	341X/R003 dry faster and dry spray will sit on top of the primer on larger trailers	341X017 stays wet a little longer so dry spray melts back into the primer on larger trailers
DRY FILM THICKNESS RECOMMENDATIONS (1 mil=1 thousandth of an inch)	1.0 mil primer; 1.5-2.0 mil topcoat; 2.5-3.5 mil total film	1.0 mil primer; 1.5-2.0 mil topcoat; 2.5-3.5 mil total film
TYPE OF TRAILERS DESIGNED FOR:	Small trailers, and flatbed gooseneck trailers	Horse and Stock Trailers, quality built small and flatbed trailers
OPTIONAL ADDITIVES		
URETHANE HARDENER:	Yes	Yes
PURPOSE OF URETHANE HARDENER:	"Improves Gloss, durability, chemical resistance, and chip resistance"	"Improves Gloss, durability, chemical resistance, and chip resistance"
DOES PAINT JELL WITH URETHANE HARDENER:	Yes - Must use paint in 4-6 hours	Yes - Must use paint in 4-6 hours
PAINT REDUCING GUIDELINES FOR PRIMER AND TOPCOAT		
IF BOOTH TEMPERATURE IS 75°F or LESS	DER45-75 Fast Reducer	DAR45-75 Fast Reducer
IF BOOTH TEMPERATURE IS 60°F to 90°F	DER65-90 Medium Reducer	DAR65-90 Medium Reducer
IF BOOTH TEMPERATURE IS OVER 90 °F	DER85-100 Slow Reducer	DAR85-100 Slow Reducer
OTHER SPECIFICATIONS		
TYPE OF PAINT:	Alkyd Enamel	Acrylic Enamel
DRY TIME TO WORK ON TRAILER:	10-15 minutes at 77°F	10-15 minutes at 77°F
DRY HARD:	72 hours	72 hours
EASE OF APPLICATION:	Good	Excellent
GLOSS:	Good	Excellent
WATER SPOT RESISTANCE:	Good	Excellent
TIME TO START LOSING MOST OF GLOSS:	1 - 1.5 Years	3.5 - 4 Years
OPTIONAL ADDITIVES		
GLOSS ENHANCER:	Yes	No
PURPOSE OF GLOSS ENHANCER:	Improves gloss, durability. Converts Trailglo into an acrylic-modified enamel	N/A
DOES PAINT JELL WITH GLOSS ENHANCER:	No - Can use paint with gloss enhancer added at any time	N/A

## Valspar Trailglo Enamel

Color	16 oz. Spray Can		1 Gallon		5 Gallon	
	Part No.	Ref. No.	Part No.	Ref. No.	Part No.	Ref. No.
National Blue	742A330-16	360804	742A330-1	360806	742A330-5	360811
Gloss Black	742B301-16	360814	742B301-1	360816	742B301-5	360821
Fleet White	742W370-16	360824	742W370-1	360826	742W370-5	360831
Desert Tan	742N380-16	360834	742N380-1	360836	742N380-5	360841
Cat Yellow	742Y390-16	360850	742Y390-1	360853	742Y390-5	360856
Teal Metallic	742G338-16	360858	742G338-1	360859	742G338-5	360860
Bright Red	742R395-16	360861	742R395-1	360862	742R395-5	360863
International Red	742R352-16	360865	742R352-1	360866	742R352-5	360869
Implement Green	742G340-16	360871	742G340-1	360874	742G340-5	360876
Candy Apple Red	742R373-16	360879	742R373-1	360881	742R373-5	360883
Regatta Blue Metallic	742A308-16	360886	742A308-1	360888	742A308-5	360891
Gray Metal	742X302-16	360894	742X302-1	360896	742X302-5	360901
Midnight Blue Metallic	742A312-16	360903	742A312-1	360906	742A312-5	360908
Silver Metallic	742S325-16	360918	742S325-1	360920	742S325-5	360923
Dark Red	742R348-16	360924	742R348-1	360926	742R348-5	360928

## Valspar Supreme Acrylic Enamel

Color	1 Gallon		5 Gallon	
	Part No.	Ref. No.	Part No.	Ref. No.
Standard Red	750R927-1	359752	750R927-5	359753
Cherry Red Metallic	750R994-1	359754	750R994-5	359755
Linen White	750W959-1	359756	750W959-5	359757
Gray Metallic	750X902-1	359758	750X902-5	359759
Silver Metallic	750S926-1	359760	750S926-5	359761
Light Driftwood Metallic	750N937-1	359762	750N937-5	359763
Amazon Green Pearl	750G945-1	359766	750G945-5	359767
Cadet Blue Metallic	750A925-1	359770	750A925-5	359771
Coach Black	750B989-1	359778	750B989-5	359779
Space Blue Metallic	750A923-1	359780	750A923-5	359781
Indigo Blue Metallic	750A939-1	359782	750A939-5	359783
Dark Teal Metallic	750G932-1	359784	750G932-5	359785
Pewter Metallic	750N912-1	359786	750N912-5	359787
Dark Garnet Red Pearl	750R950-1	359788	750R950-5	359789
Vermillion Red	750R970-1	359790	750R970-5	359791



CHEMICALS  
& COATING

## Painting Tips



### SURFACE PREPARATION

Dirt, oil, grease, or other contaminants can cause loss of adhesion or surface imperfections, resulting in problems that may show up immediately or after a period of months. The following recommendations can be used as a guide in cleaning the surface to be painted.

**BARE STEEL:** Use a grease and wax removing solvent (*Metal Surface Cleaner-See instructions below*) to remove the dirt, oil, grease, and other contaminants that have collected on the metal. Washing with detergent and water may also be done if rinsed well. Be sure care is taken to completely dry the metal before painting.

**PAINTED SURFACES:** It is recommended the entire surface be sanded with 220-280 grit sand paper before painting. Wash with detergent and water, rinse well and allow to completely dry. Solvent clean with a grease and wax remover (*Metal Surface Cleaner-See instructions below*) to remove any oils, waxes, or other contaminants that may be left on the surface. All broken areas of paint must be feather edged to prevent lifting and improve appearance.

### REDUCTION/MIXING RATIOS

#### PAINTS & PRIMERS:

As a starting point, it is recommended that Paints & Primers be reduced 20-25% with the proper Reducer for current temperature conditions. Reduction Ratio should then be adjusted, if necessary, for painting conditions and style of application. If you have any questions, contact your nearest Redneck Location for assistance.

#### HARDENER:

Hardener should be used at an 8 to 1 ratio (1 pint to 1 gallon), adding hardener to paint BEFORE paint is reduced. Paint with hardener mixed in should be used within 4 hours after adding hardener. Any material sprayed after 4 hours may have lower gloss. Clean all paint equipment immediately after use, as the material will "gel" if left in the fluid lines, etc., causing permanent damage. The paint should not gel in less than 8 hours.

### SAFETY

This product contains solvents and/or other chemical ingredients. Adequate health and safety precautions should be observed during all storage, handling, use and drying periods. For safest usage, user is specifically directed to consult the current material safety data sheet for this product. (Additional copies available upon request.)

**Contact Redneck Trailer Supplies for additional assistance.**

*The information contained herein is to our knowledge true and accurate. All recommendations are made without guarantee since the conditions and applications are beyond our control. We recommend all products be tested by the customer to determine the suitability to the end use requirements.*

### COMMON PAINT PROBLEMS

**FISH EYES:** Small, crater-like openings in the finish after it has been applied.

**Causes:** Improper surface cleaning or preparation. Contamination of air lines.

**LIFTING:** Surface distortion or shriveling, while the topcoat is being applied or while drying.

**Causes:** Wrong thinner or reducer.

**ORANGE PEEL:** Uneven surface formation, much like that of the skin of an orange. Paint droplets dry out before they can flow together.

**Causes:** Improper gun adjustment and techniques. Too little air pressure, wide fan patterns or spraying at excessive gun distances. Wrong thinner or reducer. Reduced paint thinned with fast evaporating reducer. Atomized droplets become too dry before reaching surface. Too little thinner or reducer. Materials not uniformly mixed.

**PINHOLING:** Tiny holes or groups of holes in the finish or primer. Usually the result of trapped solvents, air, or moisture.

**Causes:** Improper surface cleaning or preparation. Moisture left on primer will pass through the wet topcoat to cause pinholing. Contamination of air lines. Moisture or oil in air lines will enter paint while being applied and cause pinholes when released during the drying stages.

**RUNS OR SAGS:** Heavy application of sprayed material that fails to adhere uniformly to the surface.

**Causes:** Too much or wrong thinner/reducer. Excessive film thickness without allowing proper dry time. Shop or surface too cold.

**CHALKING:** Formation on the paint finish caused by pigment powder no longer held together by the resin, which makes the finish look dull.

**Causes:** (other than normal weathering) The wrong type of reducer which can harm topcoat durability. Too little primer or topcoat applied. Excessive mist coats when finishing a metallic color application.

## Instructions For Application of Metal Surface Cleaner

- Always use clean, lint-free rags. Do not use shop towels or grease rags. Do not reuse rags.
- Pour cleaner on rag. Do not dip dirty rag into cleaner.
- Do not let cleaner set or soak on previously painted or primed surfaces. You may use cleaner to wipe down painted or primed surfaces, however, if cleaner puddles or soaked rag sets on painted or primed surfaces, the paint or primer will soften and begin to dissolve, thereby forcing you to remove the paint or primer down to bare metal.
- Start at the top and work your way down.
- Wipe evenly and rotate to a clean area of rag often to avoid recontaminating cleaned surface with a dirty rag.
- To determine if surface is clean: Properly cleaned surface will sheet water off; beading indicates an oily surface.
- Cleaner must be totally evaporated before priming or painting. The surface should be dry to the touch. Depending on humidity and ambient temperature, cleaner will evaporate within 20-30 minutes.
- Handling of cleaned surfaces may cause rusting or contamination.
- Although this cleaner has a higher flash point (143 deg. F) which makes it "less flammable" and has less odor than most cleaning solvents, the use of gloves and safety glasses is still recommended. Other precautions listed on the Material Safety Data Sheet need to be followed.





## Lights & Electrical

The easy to use format of this section will help you quickly find the lights and electrical supplies you need. All lights are grouped by type and design, followed by reflectors, lighting accessories, wire, wire terminal ends, wire loom, circuit breakers, Redline trailer connectors in 4, 5, 6 and 7 pole designs and "Lite Mate" wiring systems.

Identification Light Bar	J-2	Quick Disconnects	J-16
Rectangular Clearance Light	J-3	Terminal Kit	J-16
Clearance Lights	J-4- J-5	Ring Terminal	J-16
Oblong Combination Light/Reflector	J-5	Quick Splices	J-17
Stop, Turn and Tail Light	J-6	Wire Nut	J-17
Sealed Marker Lights	J-7	Bullet Connectors	J-17
Combination Taillight	J-7	Butt Connectors	J-17
License Lights	J-8	Spade Terminals	J-17
Sealed Stop, Turn and Tail Lights	J-8	Wire Grommets	J-18
Utility Light	J-9	Cable Ties	J-18
Tractor Utility Light	J-9	Loom Clamp	J-18
Backup Lights	J-9	Wire Loom	J-18
Snap-in License / Utility Light	J-9	Fuses	J-19
Interior Lights with Switch	J-10	Spring Steel Wire Clip	J-19
Interior and Compartment Light	J-10	Fuse Holders	J-19
Porch and Utility Light	J-10	Circuit Tester	J-19
Dome Light with Switch	J-10	Heavy Duty Terminal Pliers	J-19
Trailer Light Kits	J-10	Electrical Tape	J-19
Reflectors	J-11	Turn Signal Flashers	J-20
Auxiliary Towing Light Kit	J-11	Circuit Breakers	J-20
Conspicuity Reflectors	J-12	Push-Pull Switches	J-20
Conspicuity Tape	J-12	Toggle Switches	J-20
Microprismatic Reflectors	J-12	Trailer Connector	J-21- J-25
Rectangular Reflector	J-12	Transmission Oil Coolers	J-21
Lighting Accessories	J-13	Wiring Harness Kits	J-24
Light Guards	J-13	Junction Boxes	J-25
Bulbs	J-13	Molded Rubber Trailer Cords	J-25
Primary Wire	J-14	Trailer Connector Adapters	J-28
Insulated Lighting Cable	J-15	Taillight Converters	J-28
Jacketed Duplex Brake Wire	J-15	Connector Brackets	J-28
Bonded Parallel Primary Wire	J-15		

### Identification Mini-Light Bar

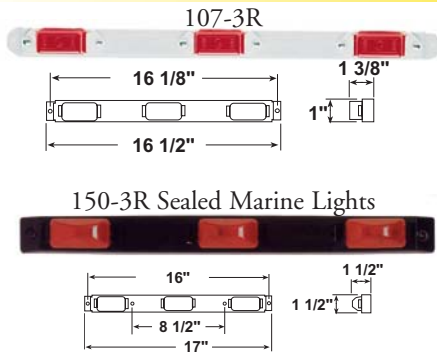

The 107 Series light bar has three mini lights and contains 194 (12V) 2500 hour heavy-duty bulbs. The 150 Series Bar features 2250 sealed lights for boat trailer use.

Part No.	Ref. No.	Description	Mounting Bar
107-3A	427800	AMBER LIGHT BAR	WHITE FINISH
107-3R	428000	RED LIGHT BAR	WHITE FINISH
150-3R	428100	RED SEALED LIGHTS	BLACK MOLDING
107-15A	443400	AMBER REPLACEMENT LENS	
107-15R	443600	RED REPLACEMENT LENS	
107WA	422400	AMBER REPLACEMENT LIGHT	
107WR	422600	RED REPLACEMENT LIGHT	

### VIBAR Identification Light Bar

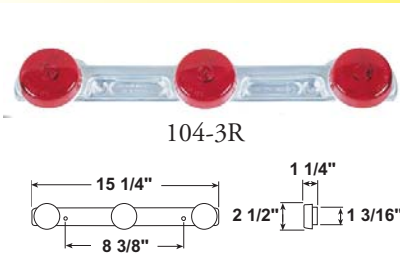

This unit has three "Champion" lights with acrylic lenses that snap and seal into the Lexan housings. The exclusive VIBAR sockets minimize premature bulb failure. The mounting bar is constructed of heavy gauge aluminum. It contains 194 (12V) 2500 hour heavy-duty bulbs.

Part No.	Ref. No.	Description	Mounting Bar
104-3R	427600	RED LIGHT BAR	ALUMINUM
100-15R	443200	RED REPLACEMENT LENS	
104R	421800	RED REPLACEMENT LIGHT	

### Thin-Line Identification Light Bar



This unit has three heavy-duty acrylic Thin-Line lenses that firmly snap into molded "O" rings on a sturdy black-finish steel bar. Attaches with two easy-access mounting holes. Only 2" wide, this unit contains 194 (12V) 2500 hour heavy-duty bulbs.

Part No.	Ref. No.	Description	Mounting Bar
136-3R	428200	RED LIGHT BAR	BLACK-FINISH STEEL
136-3A	428400	AMBER LIGHT BAR	BLACK-FINISH STEEL
136-15A	448800	AMBER REPLACEMENT LENS	
136-15R	449000	RED REPLACEMENT LENS	

### Square Lens Identification Light Bar



This unit has three square durable acrylic lenses on a zinc-plated bar. The overall size is 14 1/2" x 2 1/4" x 1 1/2" high. Attaches with 2 screws. It contains 1895 (12V) bulbs.

Part No.	Ref. No.	Description	Mounting Bar
3301	428600	AMBER LIGHT BAR	ZINC-PLATED STEEL
3302	428800	RED LIGHT BAR	ZINC-PLATED STEEL
3340	449200	AMBER REPLACEMENT LENS	
3339	449400	RED REPLACEMENT LENS	

### Bargman I.D. Bar Light



This unit has a unique design where all three ID light bulbs are recessed inside shrouds to produce an overall effect of one lens with three individual light sources.

Part No.	Ref. No.	Description	Mounting Bar
IDL99-111	428850	RED LIGHT BAR W/ SPOTLIGHTS	WHITE POLY

## Rectangular Combination Light/Reflector Single Stud Mount

The Combination Side Marker or Clearance Light also acts as a Class A Reflector. Mounts with a single 1/4" diameter stud. Features a patented VIBAR socket which extends bulb life. It contains a 194 (12v) 2500 hour heavy-duty bulb.

Part No.	Ref. No.	Description
114A	423200	AMBER LIGHT
114R	423400	RED LIGHT
55-15A	442600	AMBER REPLACEMENT LENS
55-15R	442800	RED REPLACEMENT LENS

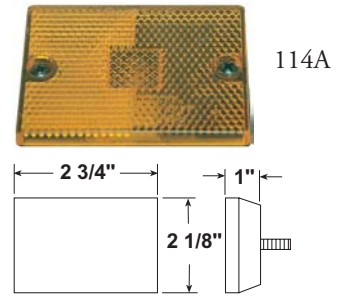

## Rectangular Combination Light/Reflector Surface Mount

The Combination Side Marker or Clearance Light also acts as a Class A Reflector. Mounts with two screws without disassembly. The rugged molded housing protects the recessed lens from rocks and gravel. All the metal parts are stainless steel, so the light will not corrode. It contains a 194 (12V) 2500 hour heavy-duty bulb.

Part No.	Ref. No.	Description	Housing
115A	423600	AMBER LIGHT	BLACK MOLDING
115R	423800	RED LIGHT	BLACK MOLDING
55-15A	442600	AMBER REPLACEMENT LENS	
55-15R	442800	RED REPLACEMENT LENS	

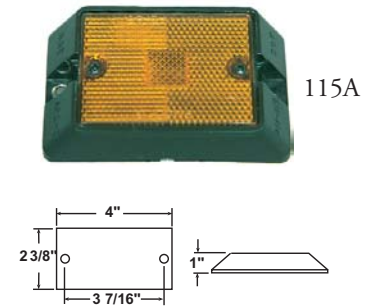

## Rectangular Clearance Light

This deluxe, high-styled Clearance Light features chrome plating. A heavy molded vinyl mounting pad seals the back of the light. Requires a one inch diameter socket mounting hole. Stainless steel lens screws are included. It contains an 1895 (12V) 2000 hour heavy-duty bulb.

Part No.	Ref. No.	Description	Housing
126A	424800	AMBER LIGHT	CHROME MOLDING
126R	425000	RED LIGHT	CHROME MOLDING
126-15A	445000	AMBER REPLACEMENT LENS	
126-15R	445400	RED REPLACEMENT LENS	

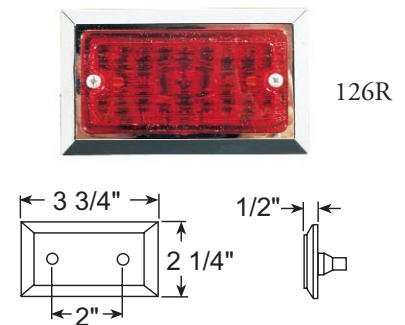

## Rectangular Two Bulb Clearance Light

This popular style Clearance Light has a molded plastic base containing two VIBAR sockets for prolonged bulb life. All metal parts are tinned brass. It contains 194 (12V) 2500 hour heavy-duty bulbs.

Part No.	Ref. No.	Description
138A	425600	AMBER LIGHT
138R	425800	RED LIGHT
138-15A	446000	AMBER REPLACEMENT LENS
138-15R	446200	RED REPLACEMENT LENS

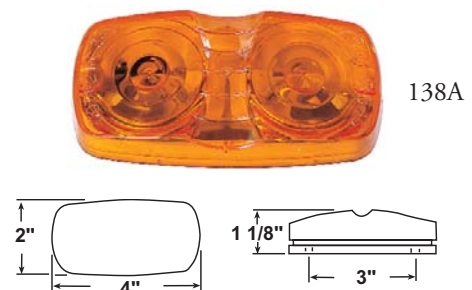

### Steel Armored Clearance Light



119R

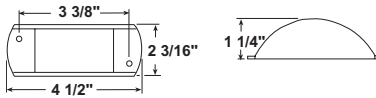

The acrylic lens is guarded by a 14 gauge bright plated steel housing, can be spot-welded to trailer rails and mounts without disassembly. The patented VIBAR socket minimizes premature bulb failure. Contains a 194 (12V) 2500 hour heavy-duty bulb.

Part No.	Ref. No.	Description	Housing
119A	424000	AMBER LIGHT	CHROME-PLATED STEEL
119R	424200	RED LIGHT	CHROME-PLATED STEEL
119-15A	444200	AMBER REPLACEMENT LENS	
119-15R	444400	RED REPLACEMENT LENS	

### Vanguard II Clearance Light



122A



122XA

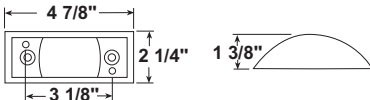

These armored Clearance Lights, available with a standard grey or chrome plated molded nylon or aluminum housings resist rust and corrosion. The patented VIBAR socket minimizes premature bulb failure. The pass-through mounting holes permit installation without disassembly and its flat back eliminates the need for a socket hole. Comes with a Lexide Mounting Gasket. Contains a 194 (12V) 2500 hour heavy-duty bulb.

Part No.	Ref. No.	Description	Housing
122A	424300	AMBER LIGHT	GREY MOLDING
122R	424350	RED LIGHT	GREY MOLDING
122XA	424400	AMBER LIGHT	CHROME MOLDING
122XR	424600	RED LIGHT	CHROME MOLDING
124A	424650	AMBER LIGHT	ALUMINUM MOLDING
124R	424700	RED LIGHT	ALUMINUM MOLDING
124-15A	444600	AMBER REPLACEMENT LENS	
124-15R	444800	RED REPLACEMENT LENS	

### Thin-Line Clearance Light



M136A

This Clearance Light in a non-corrosive, shock-absorbing molded housing is designed for narrow rails and channels where 2" wide lights will not fit. Featuring a cellulose sponge mounting pad, it measures 3 1/2" x 1 1/8" high with two 13/64" mounting holes on 2 3/4" centers and contains a 194 (12V) bulb.

Part No.	Ref. No.	Description
M136R	427200	RED LIGHT
M136A	427400	AMBER LIGHT
136-15A	448800	AMBER REPLACEMENT LENS
136-15R	449000	RED REPLACEMENT LENS

### Mini Clearance Light



107WR

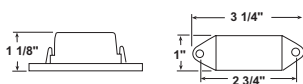

This Light is unbelievably compact yet packed with quality features. The acrylic lens locks into the base and is highly resistant to being knocked out. It contains a 194 (12V) 2500 hour heavy-duty bulb.

Part No.	Ref. No.	Description	Housing
107WA	422400	AMBER LIGHT	WHITE MOLDING
107WR	422600	RED LIGHT	WHITE MOLDING
107-15A	443400	AMBER REPLACEMENT LENS	
107-15R	443600	RED REPLACEMENT LENS	

### Combination Clearance/Side Marker Light - Fender Mount



This Clearance/Side Marker Light does the job of two lights. The Lexan® lens is held in place by two stainless steel screws which mount the light onto a fender. Measures 3 11/16" X 1 5/16" X 1 1/2" (w/ 1/2" depth). Includes 25" long 2-wire pigtail.

Part No.	Ref. No.	Description	Housing
FL40-0004	427500	AMBER / RED FENDER LIGHT	BLACK PLASTIC

## Oblong Combination Light/Reflector

This Light and Class A Reflector combination features "cross- optics" for a brilliant signal and patented VIBAR sockets to prolong bulb life. Contains one or two 194 (12V) 2500 hour bulbs.

Part No.	Ref. No.	Description
108WA	422800	AMBER LIGHT WITH SINGLE BULB
108WR	423000	RED LIGHT WITH SINGLE BULB
106A	422000	AMBER LIGHT WITH TWO BULBS
106R	422100	RED LIGHT WITH TWO BULBS
108-15A	443800	AMBER REPLACEMENT LENS
108-15R	444000	RED REPLACEMENT LENS

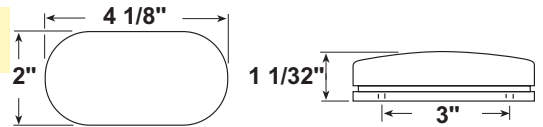

## Oblong Two Bulb Clearance Light

This Two Bulb Clearance Light features two VIBAR sockets for prolonged bulb life. The acrylic lens snaps and seals into the housing. It contains 194 (12V) 2500 hour heavy-duty bulbs.

Part No.	Ref. No.	Description
135A	425200	AMBER LIGHT
135R	425400	RED LIGHT
134-15A	445600	AMBER REPLACEMENT LENS
134-15R	445800	RED REPLACEMENT LENS

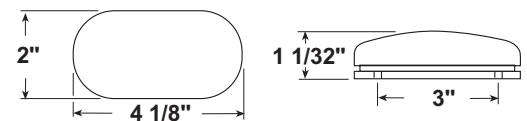

## Round Sealed Clearance Light

The 2 1/2" Round Lights have a Lexan lens and housing sonically welded into a sealed, single unit. 143 Series has a built-in Class A Reflector in the lens. 2 1/2" Round Lights require a 142-18K or 143-18K Mounting Kit. The 2" Round Lights utilize a standard lens, are used for mounting in areas with limited space and require the 146-18K Mounting Kit. Mounting Kits contain a grommet, plug and grounding screw.

Part No.	Ref. No.	Description	Type
142A	425850	AMBER, 2 1/2" ROUND	STANDARD LENS
142R	425900	RED, 2 1/2" ROUND	STANDARD LENS
143A	426000	AMBER, 2 1/2" ROUND	REFLECTOR LENS
143R	426200	RED, 2 1/2" ROUND	REFLECTOR LENS
142-18K	426800	MOUNTING KIT FOR RECESSED 2 1/2" ROUND LIGHTS REQUIRES A 3" HOLE.	
143-18K	427000	MOUNTING KIT FOR RECESSED 2 1/2" ROUND. REQUIRES A 2 25/32" HOLE.	
146A	427100	AMBER, 2" ROUND	STANDARD LENS
146R	427110	RED, 2" ROUND	STANDARD LENS
146-18K	427125	MOUNTING KIT FOR RECESSED 2" ROUND LIGHTS REQUIRES A 2 5/16" HOLE.	
142-49	426600	REPLACEMENT PLUG FOR 142,143 AND 146 SERIES LIGHTS	

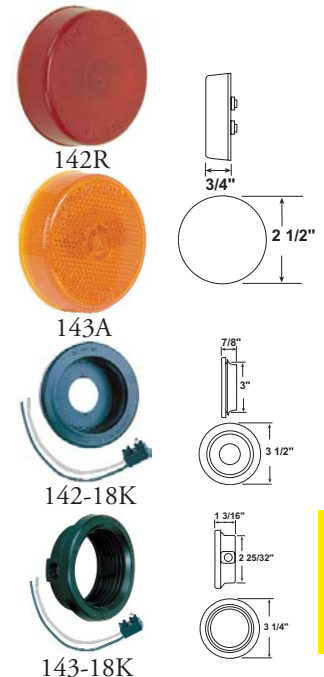

LIGHTS &  
ELECTRICAL

## "Champion" Round Clearance Light

"Champion" Lights feature Lexan housings and a VIBAR socket to extend bulb life. The acrylic lens snaps and seals into the housing. A flat back eliminates the need for a socket hole. It contains a 194 (12V) 2500 hour heavy-duty bulb.

Part No.	Ref. No.	Description
104A	421600	AMBER LIGHT
104R	421800	RED LIGHT
100-15A	443000	AMBER REPLACEMENT LENS
100-15R	443200	RED REPLACEMENT LENS

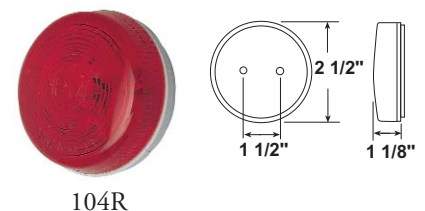

## Flush Mount Stop, Turn and Tail Light

The Flush Mount Lights provide stop, turn and tail light functions. Choose from a steel housing with black enamel finish or a 304 stainless steel housing with satin finish. Steel housing lights come with either brass or VIBAR bulb sockets. All three types come with regular, or reflex reflector optics around the periphery of the lens. All six lights feature a snap ring retaining wire to secure the lens and a 1157 (12v) bulb.



413-3



425-3

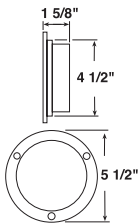

Part No.	Ref. No.	Description	Socket	Housing	Lens
413-3	429600	RED LIGHT	BRASS	POLY	REFLECTIVE
413	429650	RED LIGHT	BRASS	POLY	STANDARD
413S-3	429800	RED LIGHT	BRASS	STAINLESS STEEL	REFLECTIVE
413S	429850	RED LIGHT	BRASS	STAINLESS STEEL	STANDARD
425-3	430000	RED LIGHT	VIBAR	MILD STEEL	REFLECTIVE
425	430050	RED LIGHT	VIBAR	MILD STEEL	STANDARD
414-15C	448000	CLEAR REPLACEMENT LENS			STANDARD
415-15R	448200	RED REPLACEMENT LENS			REFLECTIVE
413-07	451000	REPLACEMENT PLUG FOR 413 SERIES & 425 SERIES LIGHTS			
410-21	447800	REPLACEMENT RETAINER RING FOR 413 SERIES & 425 SERIES LIGHTS			

## Pedestal Mount Stop, Turn and Tail Light

This durable light has a black 4 1/8" ABS housing with a snap-on red lens that functions as a stop, turn and tail light. Two lead wires exit through 1/2" diameter hollow stud. It contains a 1157 bulb.



313-2

Part No.	Ref. No.	Description	Housing	Lens
313-2	429005	RED LIGHT	BLACK POLY	
338-15A	448730	AMBER REPLACEMENT LENS		STANDARD
338-15R	448725	RED REPLACEMENT LENS		STANDARD

## Stud Mount Stop, Turn and Tail Light

Stud Mount Three Function Light performs as a stop, turn and tail light. Four Function Light performs all the same functions, plus a license illuminator. Both feature wrap-over-lens retained by two screws onto a black plastic housing making the light dust resistant. 1/4" studs include mounting hardware. Contains a 1157 bulb. Part #445 is standard on trucks such as Peterbuilt, Mack, White and Jeep.



428S

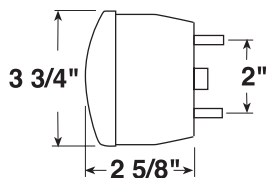

Part No.	Ref. No.	Description	Function	Housing
428S	431800	RED LIGHT	3	BLACK PLASTIC
428W	432000	RED LIGHT	4	BLACK PLASTIC
445	432500	RED LIGHT	4	BLACK PLASTIC
420-15R	448400	RED REPLACEMENT LENS FOR 428 SERIES LIGHTS		
413-07	451000	REPLACEMENT PLUG FOR 428 SERIES LIGHTS		

## Rectangular Multi-Function Combination Taillight

This Multi-Function Rear Light has a corrosion resistant molded housing and bronze contacts. No plug is required; simply insert the wire ends for a secure connection. Right Hand Light performs as a stop, turn and taillight, rear and side reflector, side marker. Rear Left Hand Light performs the same, plus has a license illuminator. Contains a 1157 and 1895 bulb.

Part No.	Ref. No.	Description	Function	Side	Application
440	432200	RED LIGHT	6	RIGHT HAND	UNDER 80" WIDE TRAILERS
440L	432400	RED LIGHT	7	LEFT HAND	UNDER 80" WIDE TRAILERS
444	432450	RED LIGHT	7	RIGHT HAND	OVER 80" WIDE TRAILERS
444L	432475	RED LIGHT	8	LEFT HAND	OVER 80" WIDE TRAILERS
55-15R	442800	RED REPLACEMENT SIDE MARKER LENS FOR 440 SERIES LIGHTS			
56-15R	448700	RED REPLACEMENT SIDE LENS FOR 444 SERIES LIGHTS			
440-15R	448600	RED REPLACEMENT LENS FOR 440 & 444 SERIES LIGHTS			

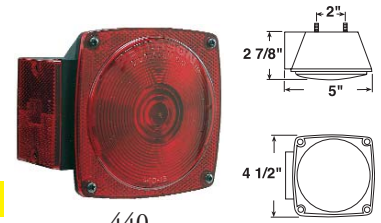

440

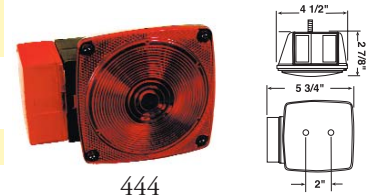

444

## Flush Mount Rectangular Combination Taillight

Five function flush mount light performs as a stop, turn and tail light, rear reflector and rear clearance light. The Lexan lens and housing are resistant to corrosion. Two VIBAR sockets ensure prolonged bulb life. This unit has color-coded wires and stainless steel lens screws. It contains two 1157 (12V) bulbs.

Part No.	Ref. No.	Description	Function	Side	Housing
430L	430600	RED LIGHT	5	LEFT HAND	WHITE MOLDED PLASTIC
430R	430800	RED LIGHT	5	RIGHT HAND	WHITE MOLDED PLASTIC



430R

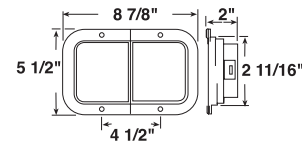

## Sealed Side Marker/Turn Signal Light

Lexan® housing and lenses are sonic welded to provide a permanent seal. Meets SAE recommended practice for side turn signals, while providing marker and reflector functions. Includes grommet and plug. Often used with mounting bracket #421-09.

Part No.	Ref. No.	Description	Housing
352KA	436650	AMBER LIGHT	WHITE MOLDED PLASTIC



## Sealed Clearance Marker Light

The Lexan sealed Clearance Marker Lights are ideal for applications where small, attractive, waterproof clearance or marker lights are desired. The 2250 and 2636 series measure 2 1/4" x 1 1/4" x 3/4". The 2637 series measures 3 13/16" x 1 1/4" x 7/8" and comes with two bulbs.

Part No.	Ref. No.	Description	Housing
2250A	435200	AMBER LIGHT	CHROME PLATED MOLDED PLASTIC
2250R	435400	RED LIGHT	CHROME PLATED MOLDED PLASTIC
2636A	435500	AMBER LIGHT	RUBBER GROMMET
2636R	435505	RED LIGHT	RUBBER GROMMET
2637A	435510	AMBER LIGHT	BLACK MOLDED PLASTIC
2637R	435515	RED LIGHT	BLACK MOLDED PLASTIC



2636R



2637R

## Flush Mount Sealed Stop, Turn and Tail Light



426KR

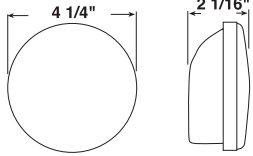

These Flush Mount Sealed Lights feature a Lexan housing and lens that's permanently sealed by a fusion bonding process. The bulb floats in a VIBAR socket for extended life. The exclusive wire connection port offers maximum corrosion protection when used with the plug and mounting grommet provided.

Part No.	Ref. No.	Description	Type
426KA	435600	AMBER LIGHT	STANDARD
426KR	435800	RED LIGHT	STANDARD
427KR	436000	RED LIGHT	REFLECTIVE
426R	435810	REPLACEMENT RED SEALED BEAM FOR 426KR	
431-491	436400	REPLACEMENT PLUG FOR 426 & 427 SERIES LIGHTS	

## Flush Mount Sealed Turn Signal Light

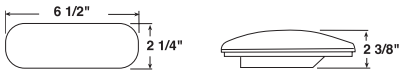

This unit is completely sealed in a Lexan housing and lens, and the bulb is shock mounted to protect it from wear and tear. This advanced design virtually eliminates rust, corrosion, filament fracture and installation or removal problems. Light is ideal for narrow widths. It is legal in either horizontal or vertical mount. The kit contains the grommet, plug and grounding screw necessary for installation.

Part No.	Ref. No.	Description
421KA	436625	AMBER LIGHT
421KR	436800	RED LIGHT
421R	436808	REPLACEMENT RED SEALED BEAM FOR 421 KR

## Surface Mount Sealed Low Profile Taillight



Hermetically sealed to protect the bulb and electrical contacts from damage by water or corrosion. Right Hand Light performs as a stop, turn and tail light, rear and side reflector, side marker and rear clearance. Left Hand Light performs the same, plus has a license illuminator.

Part No.	Ref. No.	Description	Function	Side
456L	436810	RED LIGHT	8	LEFT HAND
456	436812	RED LIGHT	7	RIGHT HAND
3504	436825	RED LIGHT	8	LEFT HAND
3554	436850	RED LIGHT	7	RIGHT HAND
3336	449425	REPLACEMENT RED LENS SET FOR 3504 & 3554 LIGHTS		

## Sealed License Plate Light

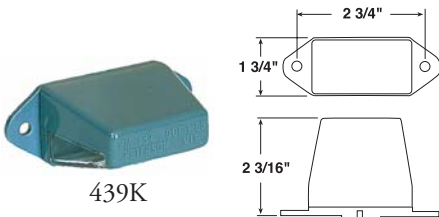

439K

This all Lexan® sealed License Illumination Light meets all federal specifications when properly mounted. Comes with plug.

Part No.	Ref. No.	Description
439K	435100	LICENSE LIGHT
439	435105	REPLACEMENT SEALED LICENSE PLATE LIGHT ONLY
142-49	426600	REPLACEMENT PLUG FOR 439K SERIES LIGHT

## VIBAR License Light

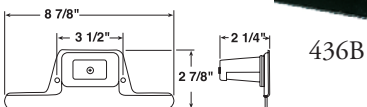

436B

This Light features Lexan housing retained with a steel screw and a VIBAR socket to extend the bulb life. All internal parts are stainless steel or brass. The 436B includes a heavy gauge black steel bracket for license attachment and includes mounting hardware. Contains a 194 bulb.

Part No.	Ref. No.	Description
436	434400	VIBAR LICENSE LIGHT
436B	434600	LICENSE LIGHT WITH BRACKET



### Snap-in License / Utility Light

This chrome plated steel Light snaps in a 1 1/4" diameter hole. Ideal for courtesy lights, instrument lights and license lights. Two units required for legal license illumination. It contains a 67 bulb.

Part No.	Ref. No.	Description
438	434800	SNAP-IN LICENSE LIGHT

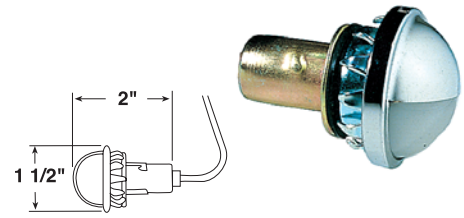

### Backup Light

Backup Light with the stainless steel housing utilizes the standard 4 1/4" clear lens (#414-15C) held in place by a retainer ring. The sealed backup lights feature a clear Lexan lens and VIBAR socket. Both come with a plug and mounting grommet.

Part No.	Ref. No.	Description	Housing
411SC	429870	CLEAR BACKUP LIGHT	STAINLESS STEEL
415K	436200	CLEAR BACKUP LIGHT	SEALED (GROMMET)
416K	436600	CLEAR BACKUP LIGHT	SEALED (GROMMET)
414-15C	448000	CLEAR REPLACEMENT LENS FOR 411SC	
411-07	450800	REPLACEMENT PLUG FOR 411 SC	



### Rectangular Backup Light

This popular design has a tough Lexan lens featuring pillow optics for maximum light dispersion. It measures 4 9/16" x 2 1/2" x 1 3/4" high. Contains a 1141 bulb.

Part No.	Ref. No.	Description	Type
393C	433800	CLEAR BACKUP LIGHT	SURFACE MOUNT



### Tractor Utility Light

507-12 Tractor Light has a 3,000 candle power trapezoidal beam pattern. It is mounted in a black rubber housing for increased shock resistance. A 5/16" mounting stud and swiveling bracket permit installation on horizontal, vertical or slanted surfaces. The horizontal adjustment is 360 degrees, vertical adjustment 90 degrees forward and 90 degrees back. The overall diameter is 4 3/4", installed height 5 7/8", depth 2 3/4". It contains a par 36, 12 volt sealed beam.

Part No.	Ref. No.	Description	Housing
507-12	434010	CLEAR TRACTOR OR UTILITY LIGHT	BLACK RUBBER



LIGHTS &  
ELECTRICAL

### Utility Light

517 Mini Halogen Light features black plastic housing, low rectangular profile with swivel mounting 2 3/8" stud and stainless steel external hardware for corrosion-free service. Loading light for truck beds, van-type trailers, etc.

Part No.	Ref. No.	Description	Housing
517	434150	CLEAR HALOGEN UTILITY LIGHT	BLACK PLASTIC



### Dome Light with Switch



A rugged polypropylene housing and a tough, flexible high density lens combine to make this unit ideal for high impact and area usage. The lens is virtually indestructible...it will give and flex rather than shatter or crack. The light is operated by a push-type on/off switch. Grounds through mounting screws. The lens diameter is 4 13/16", housing diameter is 6 5/16" and height is 2". It contains a 1141 bulb.

Part No.	Ref. No.	Description	Housing
390S	433200	WHITE DOME LIGHT	WHITE
389S	433075	WHITE DOME LIGHT	ALUMINUM

### Porch and Utility Light

**Bargman®**



Compact exterior light with black rocker switch is designed for surface mounting. Features clear snap-in lens and two wire construction (supply and ground). Measures 5 5/16" x 3 1/2" x 2".

Part No.	Ref. No.	Description	Housing
UPL78-503	433060	CLEAR PORCH OR UTILITY LIGHT	COLONIAL WHITE

### Interior and Compartment Light



This durable surface mount light measures 4 9/16" x 2 1/2" x 1 3/4" high. Features a Lexan lens, a long-life all-nylon on/off push switch and is supplied with ground wires for mounting on non-metalic surfaces. It contains a 1141 bulb.

Part No.	Ref. No.	Description
391	433600	CLEAR INTERIOR AND COMPARTMENT LIGHT
391-25	447000	CLEAR REPLACEMENT LEXAN LENS

### Interior Light with Switch

**Bargman®**



IL93-113

IL93-213

Single or Double Interior Lights with black rocker switch are designed for surface mounting. Feature high output, clear acrylic optic lens and two wire construction (supply and ground). IL93-113 measures 6 1/2" x 4 7/16" x 1 3/4", IL93-213 measures 11 1/2" x 4 17/16" x 1 3/4".

Part No.	Ref. No.	Description	TYPE	Housing
IL93-113	433300	CLEAR INTERIOR LIGHT	SINGLE	POLAR WHITE
IL93-213	433310	CLEAR INTERIOR LIGHT	DOUBLE	POLAR WHITE

### Trailer Light Kit



Kits feature the 440 Combination Rear Light with special electrical connections that eliminate external wiring splices. Wiring harnesses simply plug into the back of the lights. The Kits provide all legal lighting and reflective equipment for any trailer less than 80" wide. Front side marker lights have built-in reflectors and mount with a single stud. Kits include a four wire split harness, frame clips, flexible plastic license bracket and wire nuts.

Part No.	Ref. No.	Description	Wiring Harness
540	432600	TRAILER LIGHT KIT	20 FT LONG
545	432800	TRAILER LIGHT KIT	25 FT LONG

## Auxiliary Towing Light Kit

Safe towing made easier! Consists of two magnetic mounting taillights, a wire harness and a flat 4-way connector. The light kit works great for RV's towing vehicles, tow trucks hauling cars, for transporting portable compressors or other equipment at night, trailers with electrical problems, or any time tail-lights are needed in a temporary towing situation.



Part No.	Ref. No.	Description	Wiring Harness
ATL20A	432900	MAGNETIC MOUNT TOW LIGHT KIT	20 FT LONG

## Aluminum Oval Reflector

This is a rustproof Reflector with a 3" diameter acrylic lens.

Part No.	Ref. No.	Description	Housing
B472A	437000	AMBER REFLECTOR	ALUMINUM
B472R	437200	RED REFLECTOR	ALUMINUM

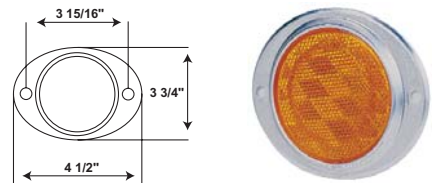

## Quick Mount Reflector

An adhesive backing permanently mounts these reflectors to any clean, flat surface.

Part No.	Ref. No.	Description	Diameter
B475A	437400	AMBER REFLECTOR	3"
B475R	437600	RED REFLECTOR	3"
B481A	439000	AMBER REFLECTOR	2 3/8"
B481R	439200	RED REFLECTOR	2 3/8"



B481R

## Center Mount Reflector

These hermetically sealed reflectors mount with a single screw through a center hole.

Part No.	Ref. No.	Description	Diameter
B476A	437800	AMBER REFLECTOR	3"
B476R	438000	RED REFLECTOR	3"
B477A	438200	AMBER REFLECTOR	2 3/8"
B477R	438400	RED REFLECTOR	2 3/8"



B476A



B477R

## Oblong Quick Mount Reflector

An adhesive backing permanently mounts this Reflector to any clean, flat surface. The reflector is hermetically sealed acrylic.

Part No.	Ref. No.	Description	Size
B480A	438600	AMBER REFLECTOR	4 3/8" x 1 7/8"
B480R	438800	RED REFLECTOR	4 3/8" x 1 7/8"



B480A

## Rectangular Reflector



B484R



B487A

Choose from attractive self-mount reflectors with or without chrome trim or a standard style reflector that mounts with 2 screws.

Part No.	Ref. No.	Description	Size	Mounting Type
B483A	439210	AMBER REFLECTOR	1 3/8" X 3 1/8"	ADHESIVE BACKING
B483R	439220	RED REFLECTOR	1 3/8" X 3 1/8"	ADHESIVE BACKING
B484A	439400	AMBER, CHROME PLATED BEVEL	7/16" X 1 11/16"	ADHESIVE BACKING
B484R	439600	RED, CHROME PLATED BEVEL	7/16" X 1 11/16"	ADHESIVE BACKING
B487A	439800	AMBER	4 1/4" X 1 5/16"	ADHESIVE BACKING & MOUNTING HOLES
B487R	440000	RED	4 1/4" X 1 5/16"	ADHESIVE BACKING & MOUNTING HOLES

## Microprismatic Reflectors

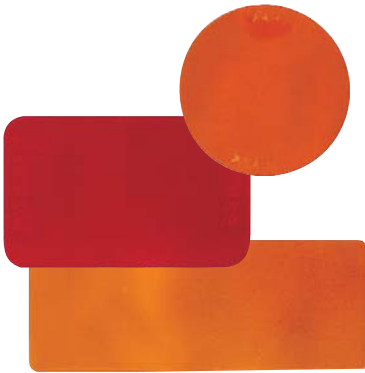

Feature state-of-the-art technology which provides 47,000 microprisms per square inch, 50% wider angle of reflectivity compared to conventional reflectors. Strong adhesive back.

Part No.	Ref. No.	Description	Size
B489A	440200	AMBER RECTANGULAR REFLECTOR	2 3/4" X 1 3/4"
B489R	440400	RED RECTANGULAR REFLECTOR	2 3/4" X 1 3/4"
B490A	440600	AMBER ROUND REFLECTOR	2 7/8" DIAMETER
B490R	440800	RED ROUND REFLECTOR	2 7/8" DIAMETER
B491A	441000	AMBER RECTANGULAR REFLECTOR	4 5/16" X 1 13/16"
B491R	441200	RED RECTANGULAR REFLECTOR	4 5/16" X 1 13/16"

## Conspicuity Tape



3M™ Scotchlite™ Diamond Grade™ Conspicuity sheeting increases nighttime visibility with 900 candlepower and 90 degree reflectivity. Product complies with NHTSA and DOT-C2.

Part No.	Ref. No.	Description	Color	Size
29804	441300	CONSPICUITY TAPE	WHITE	2" WIDE, 150' ROLL
29868	441350	CONSPICUITY TAPE	11" RED / 7" WHITE	2" WIDE, 150' ROLL
31568	441360	CONSPICUITY TAPE	6" RED / 6" WHITE	2" WIDE, 150' ROLL
6398*	441375	CONSPICUITY TAPE KIT	11" RED / 7" WHITE	2" x 75' ROLL, 4 QTY 2" x 12" STRIPS
29845	441380	CONSPICUITY TAPE KIT	11" RED / 7" WHITE	100 QTY 2" x 18" STRIPS

\* The 6398 Kit will mark one trailer up to 48 ft.

## Conspicuity Reflector

Self adhesive 1" conspicuity reflectors comply with NHTSA ruling, when applied to meet the 2" width requirement. An attractive alternative to 2" conspicuity tape.



Part No.	Ref. No.	Description	Color	Size
280RC	441370	CONSPICUITY REFLECTOR	RED	1" x 12"
280BC	441310	CONSPICUITY REFLECTOR	WHITE	1" x 12"
280ASSORT*	441305	CONSPICUITY REFLECTOR KIT	RED/WHITE	1" x 12"

\* The 280ASSORT Kit includes 28 qty of each color for a total of 56 reflectors

## Bulbs

These long-life 12-volt Bulbs are replacement bulbs for our Clearance, Combination, License and Utility/Interior Lights. Ten per box.

Part No.	Ref. No.	Description
67	449800	SINGLE FILAMENT BULB USED IN MOST LICENSE PLATE LIGHTS
194	450000	SINGLE FILAMENT PUSH-IN TYPE BULB USED IN MANY CLEARANCE LIGHTS
1141	450200	SINGLE FILAMENT BULB USED FOR MANY UTILITY AND INTERIOR LIGHTS
1157	450400	DOUBLE FILAMENT BULB USED IN STOP, TURN AND COMBINATION LIGHTS
1895	450600	SINGLE FILAMENT BULB USED IN MOST CLEARANCE LIGHTS



## Light Guards

Metal light guards provide added protection for various kinds of lights. Mounts with two screws (not included).

Part No.	Ref. No.	Description	Finish
106-09	442400	METAL GUARD FOR CLEARANCE LIGHTS	CHROME
LG440	442460	METAL GUARD FOR 440 LIGHTS	PRIMER
LG428	442450	METAL GUARD FOR 428 LIGHTS	PRIMER

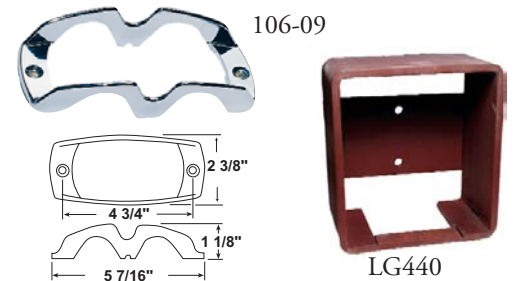

## Lighting Accessories

Part No.	Ref. No.	Description	Material	Application
428-09	441400	LICENSE BRACKET	ZINC PLATED STEEL	ALL PETERSON TAILLIGHTS
440-09	441600	LICENSE BRACKET	BLACK PLASTIC	ALL PETERSON TAILLIGHTS
510-9	441800	TAILLIGHT BRACKET	BLACK STEEL	ALL PETERSON TAILLIGHTS
426-09	442000	TAILLIGHT BRACKET	BLACK STEEL	426 SERIES, 413 SERIES, 411SC, 415K, & 425 SERIES
421-09	442200	OVAL LIGHT BRACKET	BLACK STEEL	421 SERIES, 352KA & 416K
TLB-1	442300	TAILLIGHT BRACKET	12 GA. STEEL	2-STUD MOUNT TAILLIGHTS
142-49	426600	REPLACEMENT PLUG	2-WIRE	142 SERIES, 143 SERIES, 146 SERIES & 439K
431-491	436400	REPLACEMENT PLUG	3-WIRE	426 SERIES, 427 SERIES
411-07	450800	REPLACEMENT PIGTAIL	10" WIRE	411SC
413-07	451000	REPLACEMENT PIGTAIL	2-10" WIRES	410-2, 428 SERIES, 413 SERIES
410-21	447800	REPLACEMENT RETAINING SNAP-RING		425 SERIES, 413 SERIES



TLB-1



431-491



142-49

## Primary Wire

Standard copper Primary Wire is widely used in the trailer and automotive industry for original equipment and replacement wiring. The General Purpose Thermo-Plastic (GPT) Insulation is highly resistant to acids, gasoline, oil, grease and most industrial solvents. Meets SAE J1128 Specifications. For use with 50 volts or less, 176°F (80°C).



### 10 Gauge

#### 100 ft. Roll

Color	Part No.	Ref. No.
BLUE	10-1-100BE	456400
BLACK	10-1-100BK	456600
RED	10-1-100RD	456800

### 12 Gauge

#### 100 ft. Roll

#### 500 ft. Roll

Color	Part No.	Ref. No.	Part No.	Ref. No.
BLUE	12-1-100BE	455600	12-1-500BE	459800
BLACK	12-1-100BK	455800	12-1-500BK	460000
RED	12-1-100RD	456000	12-1-500RD	460200
WHITE	12-1-100WE	456200	12-1-500WE	460400

### 14 GAUGE

#### 100 ft. Roll

#### 500 ft. Roll

Color	Part No.	Ref. No.	Part No.	Ref. No.
BLUE	14-1-100BE	454200	14-1-500BE	458400
BLACK	14-1-100BK	454400	14-1-500BK	458600
BROWN	14-1-100BN	454600	14-1-500BN	458800
GREEN	14-1-100GN	454800	14-1-500GN	459000
RED	14-1-100RD	455000	14-1-500RD	459200
WHITE	14-1-100WE	455200	14-1-500WE	459400
YELLOW	14-1-100YW	455400	14-1-500YW	459600

### 16 GAUGE

#### 100 ft. Roll

#### 500 ft. Roll

#### 5,000 ft. Roll

Color	Part No.	Ref. No.	Part No.	Ref. No.	Part No.	Ref. No.
BLUE	16-1-100BE	452800	16-1-500BE	457000	16-1-5000BE	460410
BLACK	16-1-100BK	453000	16-1-500BK	457200	16-1-5000BK	460420
BROWN	16-1-100BN	453200	16-1-500BN	457400	16-1-5000BN	460430
GREEN	16-1-100GN	453400	16-1-500GN	457600	16-1-5000GN	460440
RED	16-1-100RD	453600	16-1-500RD	457800	16-1-5000RD	460450
WHITE	16-1-100WE	453800	16-1-500WE	458000	16-1-5000WE	460460
YELLOW	16-1-100YW	454000	16-1-500YW	458200	16-1-5000YW	460470

## Bonded Parallel Primary Wire

Parallel Primary Wire has two, three or four parallel conductors bonded together by Thermo-Plastic insulation, in flat ribbon configuration. Each conductor is independently color coded for easy identification. Meets SAE J1128 Specifications, for use with 50 volts or less, 176° F (80°C).

Part No.	Ref. No.	Gauge	Conductor	Roll Length	Colors
18-3B-100	460550	18	3	100 FT	YELLOW, BROWN, GREEN
18-3B-500	460600	18	3	500 FT	YELLOW, BROWN, GREEN
18-3B-2500	460650	18	3	2,500 FT	YELLOW, BROWN, GREEN
16-2B-100	460750	16	2	100 FT	RED, BLACK
16-2B-500	460800	16	2	500 FT	RED, BLACK
16-3B-100	460950	16	3	100 FT	YELLOW, BROWN, GREEN
16-3B-500	461000	16	3	500 FT	YELLOW, BROWN, GREEN
16-3B-2500	461100	16	3	2,500 FT	YELLOW, BROWN, GREEN
16-4B-100	461150	16	4	100 FT	YELLOW, BROWN, GREEN, WHITE
16-4B-500	461200	16	4	500 FT	YELLOW, BROWN, GREEN, WHITE
16-4B-1000	461210	16	4	1,000 FT	YELLOW, BROWN, GREEN, WHITE

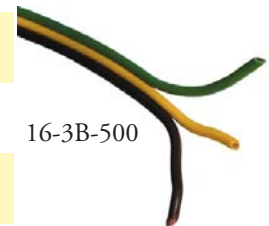

16-3B-500

## Jacketed Duplex Brake Wire

Duplex Brake Wire is made with two plastic insulated primary wires laid parallel and covered with a high quality plastic jacket, protecting the insulated conductors. Each conductor is color coded for easy identification. Meets SAE J1128 Specifications, for use with 50 volts or less, 221° F (105°C).

Part No.	Ref. No.	Gauge	Conductor	Roll Length	Colors
14-2-100	461350	14	2	100 FT	BLACK AND WHITE
14-2-500	461400	14	2	500 FT	BLACK AND WHITE
12-2-500	461600	12	2	500 FT	BLACK AND WHITE



14-2-100

## Insulated Lighting Cable

Plastic Trailer Cable is manufactured to SAE and ATA specifications. This multiconductor stranded copper wire maintains flexibility even though each conductor is insulated with a heavy vinyl covering. To provide an additional safety factor, the entire cable is enclosed in a black vinyl jacket to reduce road hazards from moisture, solvents, grease, oil, gasoline, abrasion, chemicals and weather. Conductors meet SAE J1128 Specifications, for use with 50 volts or less, 176° F (80°C).

Part No.	Ref. No.	Gauge	Conductor	Roll Length	Colors
164C500	461800	16	4	500 FT	BROWN, GREEN, RED, YELLOW
166C500	462000	16	6	500 FT	BLUE, BLACK, BROWN, GREEN, RED & YELLOW
144C500	462200	14	4	500 FT	BROWN, GREEN, RED, YELLOW
146C500	462400	14	6	500 FT	BLUE, BLACK, BROWN, GREEN, RED, YELLOW
127C500	462425	(6)12GA (1)10GA	7	500 FT	BLUE, BLACK, BROWN, GREEN, RED, YELLOW, WHITE



127C500

## Terminal Kit

Terminal Kit contains 20 of the most popular types of terminals (430 total) and one pair of Terminal Pliers for crimping terminals and cutting or stripping wire. Comes enclosed in a rust and acid resistant compartmentalized steel box. Consult the chart below for specifications of the terminals included.



TK430



Ring Terminal



Spade Terminal



Male Bullet

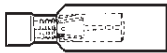

Female Bullet



Male Disconnect



Female Disconnect



Quick Splice

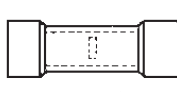

Butt Splice

Part No.	Ref. No.	Description
TK430	470600	TERMINAL KIT

### Contents of Terminal Kit

Description	Gauge	Stud Size	Color	Quantity in Kit
RING TERMINAL	22-18	10	RED	30
SPADE TERMINAL	16-14	10	BLUE	30
SPADE TERMINAL	12-10	10	YELLOW	15
RING TERMINAL	16-14	8	BLUE	30
RING TERMINAL	16-14	10	BLUE	30
RING TERMINAL	16-14	1/4"	BLUE	15
FEMALE BULLET	16-14	.157"	BLUE	15
QUICK SPLICE	18-14	N/A	BLUE	15
RING TERMINAL	12-10	10	YELLOW	15
RING TERMINAL	12-10	1/4"	YELLOW	15
RING TERMINAL	12-10	5/16"	YELLOW	15
RING TERMINAL	12-10	3/8"	YELLOW	15
MALE DISCONNECT	16-14	.250"	BLUE	25
FEMALE DISCONNECT	16-14	.250"	BLUE	30
MALE BULLET	16-14	.157"	BLUE	25
INSULATED MALE COUPLER	16-14	N/A	BLUE	15
INSULATED FEMALE COUPLER	16-14	N/A	BLUE	15
BUTT SPLICE	22-18	N/A	RED	30
BUTT SPLICE	16-14	N/A	BLUE	30
BUTT SPLICE	12-10	N/A	YELLOW	20

## Quick Disconnects

The "male" and "female" Quick Disconnects enable a fast connection or disconnection of wires. They simply crimp onto wires and plug into each other. The vinyl insulation is color coded.

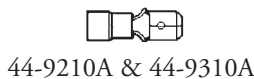

44-9210A & 44-9310A

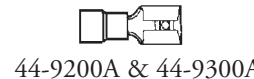

44-9200A & 44-9300A



44-9350A



44-9520A

Part No.	Ref. No.	Type	Gauge	Color	Pkg Qty	Stud Size
44-9200A	469400	FEMALE	16-14	BLUE	100	.250"
44-9210A	469600	MALE	16-14	BLUE	100	.250"
44-9300A	469800	FEMALE	12-10	YELLOW	100	.250"
44-9310A	470000	MALE	12-10	YELLOW	100	.250"
44-9350A	470200	PIGGYBACK CONNECTOR	16-14	BLUE	100	.250"
44-9520A	470400	T-TAP	18-14	BLUE	100	.250"

## Ring Terminal

Ring Terminals are used for all types of electrical work where wires need fastening. The vinyl insulation sleeves are color coded.



Part No.	Ref. No.	Gauge	Stud Size	Color	Pkg Qty
44-5210A	467600	16-14	#10	BLUE	100
44-5220A	467800	16-14	1/4"	BLUE	100
44-5230A	468000	16-14	3/8"	BLUE	100
44-5310A	468200	12-10	#10	YELLOW	100
44-5338A	468400	12-10	3/8"	YELLOW	100
44-5356A	468600	12-10	5/16"	YELLOW	100



## Spade Terminals

Spade Terminals are used for fastening wire in all kinds of electrical work. The vinyl insulation sleeves are color coded.

Part No.	Ref. No.	Gauge	Stud Size	Color	Pkg Qty
44-6110A	468800	22-16	10	RED	100
44-6210A	469000	16-14	10	BLUE	100
44-6310A	469200	12-10	10	YELLOW	100



## Butt Connectors

Butt Connectors are used to connect two wires together in-line. The plastic insulation eliminates taping and makes a neat, permanent job. Crimp with standard crimping and stripping pliers. The insulation is color coded.

Part No.	Ref. No.	Gauge	Color	Pkg Qty
44-2100A	466600	22-16	RED	100
44-2200A	466800	16-14	BLUE	100
44-2300A	467000	12-10	YELLOW	100

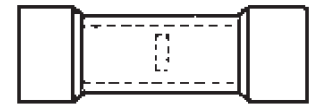

## Bullet Connectors

Wire is pushed into the insulated Female Bullet and crimped on with a pair of pliers. Male Bullet terminal crimps on to a second wire end. An electrical line is quickly connected or disconnected by snapping the two together or apart.

Part No.	Ref. No.	Description	Gauge	Stud Size	Color	Pkg Qty
44-4220A	467200	MALE BULLET	16-14	.157	BLUE	100
44-4221A	467400	FEMALE BULLET	16-14	.157	BLUE	100

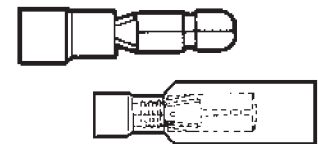

## Wire Nut

Wire Nuts connect wires by inserting all the ends and twisting. They come in standard yellow color and accept a minimum of two 18-gauge wires and a maximum of two 10 gauge wires.

Part No.	Ref. No.	Description	Gauge	Color	Pkg Qty
212	466400	WIRE NUT	MIN (2) 18 MAX (2) 10	YELLOW	100



## Quick Splices

Quick Splices strip, connect and insulate with just one squeeze of ordinary pliers. They make wire cutting, stripping, taping, soldering and splicing a thing of the past. Just insert the wire into the case and press the metal grip down with pliers, then close the case cover. Made of high impact plastic, Quick Splices are immune to grease, moisture, oil and heat.

Part No.	Ref. No.	Description	Gauge	Color	Pkg Qty
560	465800	W/STOP	18-14	BLUE	100
564	466000	W/O STOP	18-14	WHITE	100
804C	466050	W/STOP, W/CORRISON RESISTANT GEL, 3M BRAND	18-14	BLUE	500
314	466100	3 WAY, WEATHER RESISTANT GREASE FILLED, 3M BRAND	22-14	CLEAR	1,000
562	466200	W/STOP	12-10	YELLOW	100

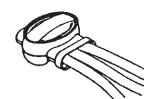
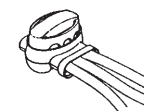
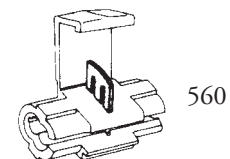

### Cable Ties



Cable Ties are a quick and easy way to mount or bunch wires together and are made of heavy-duty weather-resistant nylon.

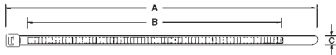

Part No.	Ref. No.	Description	A	B	C	Pkg Qty
1182	465000	CABLE TIE	7 1/2"	6"	3/16"	100
1189	465400	CABLE TIE	15"	13"	5/16"	100

### Wire Grommets



Nylon Grommets can be used where wiring passes through frame members or side panels, protecting the wire jacket from rough edges and eliminating "shorts". Simply push the grommet into the correct hole size and it will lock itself into place.

Part No.	Ref. No.	Description	I.D.	Mounting Hole
5000	462860	GROMMET	1/8"	3/16"
5008	462865	GROMMET	3/8"	1/2"
5018	462870	GROMMET	3/4"	1"

### Convolutd Wire Loom



Convolutd Loom holds wires in position and provides protection against corrosion and crushing. It is slit for easy insertion yet the slit stays closed when the wire is bent or twisted. Made of flexible black polyethylene.

Part No.	Ref. No.	Description	I.D.	Pkg. Qty.
PCT0375	462825	CONVOLUTED LOOM	3/8"	1200 FT
PCT0500	462850	CONVOLUTED LOOM	1/2"	900 FT

### Woven Cotton Wire Loom



Loom is a nonmetallic, flexible conduit used to cover wires, cables, air and hydraulic brake tubing, fuel lines and control rods. Loom is flameproof, moistureproof and will not kink. Made of woven cotton and covered with black bituminous coating

Part No.	Ref. No.	Description	I.D.	Pkg. Qty.
WCL0250	462600	COTTON LOOM	1/4"	100 FT
WCL0500	462800	COTTON LOOM	1/2"	100 FT

### Nylon Wire Loom Clamp



This durable, weather resistant Nylon Clamp is used to mount wire looms to a frame or panel surface.

Part No.	Ref. No.	Description	I.D.	Pkg. Qty.
NO250	463000	NYLON LOOM CLAMP	1/4"	100
NO375	463200	NYLON LOOM CLAMP	3/8"	100

### Metal Wire Loom Clamp

Heavy-duty Wire Loom Clamp is made of plated steel with a rubber sleeve that protects the loom and cable, and holds it securely to a frame or panel surface.



Part No.	Ref. No.	Description	I.D.	Pkg. Qty.
A0250	463400	METAL LOOM CLAMP	1/4"	100
A0375	463600	METAL LOOM CLAMP	3/8"	100
A0500	463800	METAL LOOM CLAMP	1/2"	100
A0750	464000	METAL LOOM CLAMP	3/4"	100
A1000	464200	METAL LOOM CLAMP	1"	100
A1500	464400	METAL LOOM CLAMP	1 1/2"	100

## Spring Steel Wire Clip

Wire Frame Clips are made of spring steel with black enamel finish. These Clips are used to secure one or more wires to the frame or panel surface.

Part No.	Ref. No.	Description	I.D.	Pkg. Qty.
592	464600	WIRE CLIP	3/8"	100
594	464800	WIRE CLIP	1/4"	100

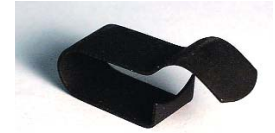

592

## Electrical Tape

This Electrical Tape is flame-retardant and weather resistant. It is UL approved 7 mil. thick, 3/4" wide and is sold in 60' long rolls. Manufactured by 3M.

Part No.	Ref. No.	Description	Size
133	465600	ELECTRICAL TAPE	3/4" X 60 FT ROLL



## Heavy Duty Terminal Pliers

This general purpose tool is used for cutting, crimping and stripping wire. Strips wire 10 - 22 gauge, crimps terminals 10 - 22 gauge.

Part No.	Ref. No.	Description
TP425	492200	HEAVY-DUTY TERMINAL PLIERS



## Circuit Tester

Used to locate shorts, broken wires and other problems. To use, attach the clip to the ground and probe with the tester point. The handle glows when a live wire is found.

Part No.	Ref. No.	Description
ECT8901	491805	6 & 12 VOLT TESTER



## Fuse Holders

Fuse holders provide circuit protection of wiring, instruments, light switches, etc.

Part No.	Ref. No.	Description
972	473200	BLADE TYPE, CRIMP-ON STYLE (FUSE NOT INCLUDED)
FH12	472800	TUBE TYPE, W/8" LOOP OF 14 GAUGE WIRE & 20 AMP FUSE
FH20ATC	473000	BLADE TYPE, W/8" LOOP OF 12 GAUGE WIRE & 20 AMP FUSE



## Fuses

ATO-ATC Plug-in, blade-type Fuses are used in most late model domestic and some import cars. SFE Fuses are the standard tube type fuse found in many automotive electrical systems. Consult your manufacturer's guide to see which is recommended for your vehicle. Sold in packages of five fuses.

Part No.	Ref. No.	Description	Amp Rating	Size
ATO-ATC20	471600	PLUG-IN BLADE FUSE	20	N/A
ATO-ATC25	471800	PLUG-IN BLADE FUSE	25	N/A
ATO-ATC30	472000	PLUG-IN BLADE FUSE	30	N/A
SFE14	472200	GLASS TUBE FUSE	14	1 1/16" LONG
SFE20	472400	GLASS TUBE FUSE	20	1 1/4" LONG
SFE30	472600	GLASS TUBE FUSE	30	1 7/16" LONG



Blade type fuse



Glass tube type fuse

## Circuit Breakers



RA2-15

Circuit Breakers convert automotive glass tube fuse systems to an automatic reset circuit without rewiring the fuse panel. They are recommended for automotive, RV, air conditioners, battery chargers, brake controllers and other applications requiring over-current protection. Circuit Breakers have a non-corrosive molded cover, nuts, washers and mounting bracket.

Part No.	Ref. No.	Description	Amp Rating
RA2-15	470800	CIRCUIT BREAKER	15
RA2-20	471000	CIRCUIT BREAKER	20
RA2-30	471200	CIRCUIT BREAKER	30
RA2-40	471400	CIRCUIT BREAKER	40

## Turn Signal Flashers



552

Replacement Turn Signal Flashers for all 12 volt, 2 terminal flashers. Replace the original flasher to eliminate the rapid flashing of turn signals due to increased amperage draw from trailer lights. Flashes 1 to 10 signaling lamps and 2 indicator lamps. The 51206 lasts up to 10 times longer than the thermal flasher.

Part No.	Ref. No.	Description	Terminals	Volts
552	473800	THERMAL FLASHER	2	12
51206	473900	ELECTRICAL-MECHANICAL FLASHER	2	12

## Toggle Switches



34-576



5543

Heavy-duty Toggle Switches are ideal for automotive, truck, farm tractor, off the road and RV applications. Switches feature a chrome knurled face nut and bat handle.

Part No.	Ref. No.	Circuitry	Terminal	Type	Volts	Amps	Stem Diameter
34-576	483400	ON-ON	6	SCREW	12	35	15/32"
34-212	483600	ON-OFF	2	SCREW	12	50	15/32"
5543	483800	ON-OFF	2	SCREW	12	10	*

\* Part #5543 mounts flush in a 2" hole.

## Push-Pull Switches

This universal all brass heavy-duty Push-Pull Switch has a number of applications, including lights, heaters, wipers, etc., for automotive, truck, marine and farm vehicles. Switches feature a polished chrome face nut and knob, with a brass back nut and washer.



Part No.	Ref. No.	Circuitry	Terminal	Type	Volts	Amps	Stem Diameter	Stem Length
33-402	484200	ON-OFF	2	SCREW	6V 12V	25A 15A	3/8"	1 1/4"

### 4 Pole Chrome Trailer Connector

The popular 4-way chrome plated zinc die cast connector. Features a spring-loaded cover, high-impact insulators and split brass contacts. 12-24 volts, 20 Amp.

Part No.	Ref. No.	Description
11-409	475600	TRAILER END CONNECTOR, 4 POLE
11-410	475800	VEHICLE END CONNECTOR, 4 POLE



### 4 Pole Zinc Die Cast Trailer Connector

This 4-way Die Cast Trailer Connector is used on agricultural and utility trailers without electric brakes. It features concealed terminals, stainless steel cover spring and finger grips for positive pull. This unit is dust and water resistant and is interchangeable with other brands of connectors.

Part No.	Ref. No.	Description
S402	476000	VEHICLE END CONNECTOR, 4 POLE
S403	476200	TRAILER END CONNECTOR, 4 POLE
S614	478800	REPLACEMENT ZINC SCREW FOR S402
S613	478600	REPLACEMENT ZINC SCREW FOR S403
S615	479000	REPLACEMENT BRASS TERMINAL SCREW FOR S402 & S403



### 5 Pole Chrome Trailer Connector

This popular 5-way chrome plated zinc die cast connector is used on small trailers where an extra circuit is needed. It features a spring-loaded cover, high-impact insulators and split brass contacts. 12-24 volts, 15 amp.

Part No.	Ref. No.	Description
11-501	476400	TRAILER END CONNECTOR, 5 POLE
11-502	476600	VEHICLE END CONNECTOR, 5 POLE



LIGHTS &  
ELECTRICAL

## 6 Pole Die Cast Trailer Connectors

The 6-way Aluminum Die Cast Trailer Connectors are ideal for horse, farm and utility trailers. They feature a concealed terminal socket design, a stainless steel cover spring and a unique cable clamp that gives more support and helps save installation time. They are dust and water resistant and interchangeable with other brands of connectors.



Part No.	Ref. No.	Description
609	477400	VEHICLE END CONNECTOR, 6 POLE
604	477600	TRAILER END CONNECTOR, 6 POLE
S602	476800	VEHICLE END CONNECTOR, HEAVY DUTY, 6 POLE
S603	477000	TRAILER END CONNECTOR, HEAVY DUTY, 6 POLE
S613	478600	REPLACEMENT ZINC SCREW FOR S603
S614	478800	REPLACEMENT ZINC SCREW FOR S602
S615	479000	REPLACEMENT BRASS TERMINAL SCREW FOR S602,& S603

### Typical Wiring Diagram for 6-way Round Connectors

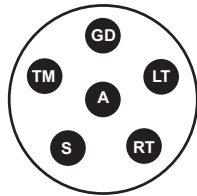

Vehicle End

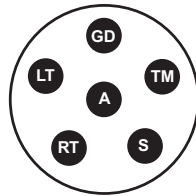

Trailer end

S*	Brakes	Blue
GD	Ground	Black
TM	Taillights	Brown
RT	Right Turn	Green
A*	Accessory	Red
LT	Left Turn	Yellow

\*Caution: Some manufacturers use "S" for Accessory and "A" for Brakes.  
Note: Locate wires by function only. Color coding is not standard among all manufacturers.

## 7 Pole Pin-Type Zinc Die Cast Trailer Connectors

This Zinc Die Cast 7-way Connector is designed for heavy-duty usage. Excellent for semi and utility trailers. The built-in slant of the socket rids the housing interior of accumulated moisture. Floating pins in the plug and socket allow for easy alignment and maximum contact. The Connector accepts the widest range of wire gauges from 14 gauge to 8 gauge ground wire and is interchangeable with other major brands. 6-28 volts, 40 amps.



Part No.	Ref. No.	Description
11-720	478000	VEHICLE END CONNECTOR, 7 POLE
11-700	477800	TRAILER END CONNECTOR, 7 POLE

### Typical Wiring Diagram for 7-Pole Pin-Type Connectors

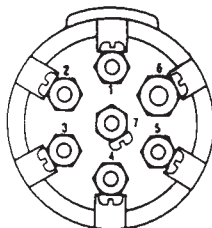

Vehicle End



Trailer end

1	Ground	White
2	Marker & Clearance	Black
3	Left Turn	Yellow
4	Stop	Red
7	Auxiliary	Blue
6	3 Bar Marker & Tail	Brown
5	Right Turn	Green

Note: Locate wires by function only. Color coding is not standard among all manufacturers.

## 7 Pole Plastic RV / Trailer Connectors

This Thermo-plastic 7-way RV Connector has brass contacts to prevent corrosion. The built-in cable clamp prevents wear on 7-way cable. Interchangeable with other 7-way RV connectors. 12 volts, 30 amps.

Part No.	Ref. No.	Description
12-707	478025	VEHICLE END CONNECTOR, 7 POLE
12-706	478050	TRAILER END CONNECTOR, 7 POLE



12-707

12-706

## 7 Pole Cadmium Plated RV / Trailer Connectors

This Connector is used on most RV travel trailers. The heavy-duty plating is for maximum weather and corrosion resistance. This connector features a stainless steel cover spring and a unique safety latch that prevents damage from accidental pull-away. It has the latest design, self-wiping pressure contacts and vinyl insert to keep out dirt. Interchangeable with other 7-way RV connectors. 12 volts, 30 amps.

Part No.	Ref. No.	Description
12-703	478200	VEHICLE END CONNECTOR, 7 POLE
12-702	478400	TRAILER END CONNECTOR, 7 POLE



12-703



12-702

### Typical Wiring Diagram for 7-Pole RV Connectors

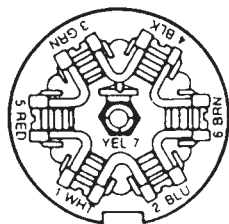

Vehicle End

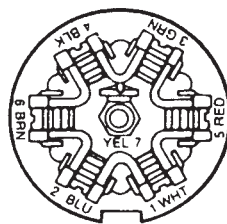

Trailer end

- |   |                     |        |
|---|---------------------|--------|
| 1 | Ground              | White  |
| 2 | Electric Brakes     | Blue   |
| 3 | Tail Running Lights | Green  |
| 4 | Battery             | Black  |
| 5 | LH Stop & Turn      | Red    |
| 6 | RH Stop & Turn      | Brown  |
| 7 | Auxiliary           | Yellow |

Note: Locate wires by function only. Color coding is not standard among all manufacturers.

## Packaged Trailer Connectors



The Most Popular Connectors for Pegboard Display in your Sales Showroom!

Part No.	Ref. No.	Description	Codes
TA01-020	474050	4-POLE FLAT CONNECTOR, VEHICLE & TRAILER ENDS, W/48" WIRE	A
TA01-060	474060	4-POLE ROUND CHROME CONNECTOR, TRAILER & VEHICLE ENDS	B
TA01-100	474080	6-POLE ZINC DIE CAST CONNECTOR, VEHICLE END	A
TA01-110	474090	6-POLE ZINC DIE CAST CONNECTOR, TRAILER END	A
TA01-120	474100	7-POLE PLASTIC RV TYPE CONNECTOR, VEHICLE END	A
TA01-125	474110	7-POLE PLASTIC RV TYPE CONNECTOR, TRAILER END	A

Popularity Codes: (A = Most popular item) (B = Fast Moving) (C = Medium) (D = Slow)



LIGHTS & ELECTRICAL

## 2 Pole Molded Rubber Trailer Harness



This Trailer Connector is used to hook up CB radios and other accessories. Includes a plug on both ends.

Part No.	Ref. No.	Description	Pole	Wire Length	Gauge
42	474200	ACCESSORY HARNESS	2	12"	18

## 4 Pole Molded Rubber Trailer Harness

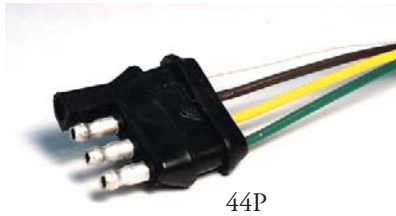

Commonly known as the "Flat, 4-way" plug, this style Trailer Connector is most widely used for boat and utility trailers without electric brakes.

Part No.	Ref. No.	Description	Pole	Wire Length	Gauge
44P	474400	TRAILER HARNESS	4	12"	(3)18GA (1)16 GA
44S	474600	VEHICLE HARNESS	4	48"	(3)18GA (1)16 GA

## 6 Pole Molded Rubber Trailer Harness



This 6 Pole Molded Rubber Trailer Connector has color-coded wires for simple installation and is polarized to ensure a proper connection. The molded case offers all-around weather protection. This Connector is used on most tent trailers.

Part No.	Ref. No.	Description	Pole	Wire Length	Gauge
46P	475000	TRAILER HARNESS	6	12"	18
46S	475200	VEHICLE HARNESS	6	48"	18

## 4 Pole "Knockout" Molded Rubber Trailer Harness Kit



The "Knockout" is a 4-way polarized (female) Molded Trailer Connector with a weather-proof dust cover that snaps into the 1 1/4" license light hole on any 8 gauge pickup bumper. There is an optional mounting bracket for vehicles without license light holes in the bumper. The "Knockout" mates with most flat 4 Pole male connectors and eliminates the unsightly under-vehicle trailer connector hanger.

Part No.	Ref. No.	Description	Pole	Wire Length	Gauge
KO4448	474800	HARNESS KIT: TRAILER HARNESS	4	8"	16
		VEHICLE HARNESS	4	30"	

## 4 Pole Molded Rubber Trailer Split Wiring Harness Kits



Used to wire stop, turn and tail lights on boat and utility trailers, complete harness includes the tow vehicle plug, and a "wishbone" type 4-conductor harness designed to split at the trailer tongue and run down each side of the trailer. The polarized flat connectors with color coded 18 gauge wires meet SAE specifications.



425YH

Part No.	Ref. No.	Description	Pole	Wire Length	Gauge
5425Y	475400	HARNESS KIT: TRAILER HARNESS	4	25'	(3) 18, (1) 16
		VEHICLE HARNESS	4	48"	(3) 18, (1) 16
3430Y	475450	HARNESS KIT: TRAILER HARNESS	4	30'	(3) 18, (1) 16
		VEHICLE HARNESS	4	48"	(3) 18, (1) 16
425YH	475500	TRAILER HARNESS	4	25'	(3) 18, (1) 16
430YH	475550	TRAILER HARNESS	4	30'	(3) 18, (1) 16



## 6 & 7 Pole Molded Rubber Trailer Cords

The 6-way and 7-way Molded Trailer Cords have encapsulated terminals and wires to form a single weather-tight, noncorrosive assembly. This feature keeps the moisture out and allows for a more secure connection.

**Bargman®**

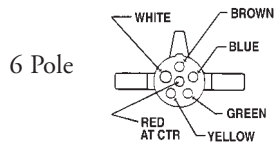

White	Ground
Blue/Black	Electric Brake
Green	Right, Stop & Turn
Red	Auxiliary
Brown	Tail & License
Yellow	Left, Stop & Turn

Part No.	Ref. No.	Description	Cable Length	Gauge
TC61-104	475570	TRAILER CORD, 6 POLE	4'	14
TC61-108	475580	TRAILER CORD, 6 POLE	8'	14



TC61-104 & TC61-108

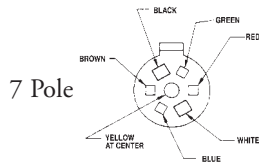

White	Ground
Blue	Electric Brake
Green	Tail & License
Black	Battery Charge
Red	Left, Stop & Turn
Brown	Right, Stop & Turn
Yellow	Auxiliary

Part No.	Ref. No.	Description	Cable Length	Gauge
TC67-003	475590	TRAILER CORD, 7 POLE	8'	(4)14 (1)12 (2)10



TC67-003

## 7 Pole Vehicle Connectors

The 7-Pole sealed Vehicle End Connector with cable features encapsulated terminals and wires to fight corrosion and ensure a quality connection. The connector is made of high strength thermo-plastic for a very attractive look. Matching metal vehicle connector brackets also available.

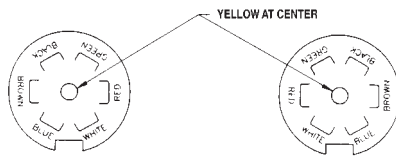

White	Ground
Blue	Electric Brake
Green	Tail & License
Black	Battery Charge
Red	Left, Stop & Turn
Brown	Right, Stop & Turn
Yellow	Auxiliary

Part No.	Ref. No.	Description	Cable Length	Gauge
TC78-004	475560	VEHICLE CONNECTOR, 7 POLE	4'	(4)14 (1)12
TC78-007	475565	VEHICLE CONNECTOR, 7 POLE	7'	(4)14 (1)12 (2)10



LIGHTS &  
ELECTRICAL

## Junction Boxes

The 6-Pole and 7-Pole Junction Boxes provide a fast, simplified way of connecting wires from the trailer connector to the trailer wiring. They provide an excellent area for trouble shooting by offering a single connection point. Each junction box is made of heavy duty plastic and includes fitted grommets making it weather proof and corrosion resistant.

Part No.	Ref. No.	Description	Hole Size
JB10-160	483000	JUNCTION BOX, 6 POLE	(2) 15/32" (2) 5/8"
JB10-170	483020	JUNCTION BOX, 7 POLE	(4)5/8"



## Vehicle-to-Trailer Wiring Systems

### One-Step: One-Piece Hook-up!



- Plug-In Simple Vehicle-To-Trailer Wiring!
- Designed For Installers & Do-It-Yourselfers
- Quick and Easy • No Cutting • No Splicing
- One Piece: T-Connector, 42" wire, & Flat 4-Way Assembly
- For 6 and 7-Way Applications, use Optional Adapters
- Models to fit most popular vehicles



**LiteMate<sup>1</sup>® Tee Connector and Wiring Harness  
w/Flat 4-Way Trailer connection All In One.**

(See Following Page for early model vehicle applications)

Part No.	Ref. No.	Fits
3034	481050	85-87 CHEVY/GM PU, 85-97 S-10/S-15
3194	481065	86-92 FORD RANGER PICK-UP
3284	481080	95-99 CHEVY SUV, CHEVY/GM 88-99 OLD STYLE PU, 92-99 SUBURBAN, 95-99 TAHOE/YUKON
3294	481110	87-96 FORD FS PICK-UP ALL
3304L	481112	97-98 FORD PICKUP, 97-99 EXPEDITION, 97 F150/F250LD
3544	481125	87-94 DODGE FS PU, 88-94 DAKOTA, 88-93 CHARGER
3614	481140	91-94 EXPLORER & NAVAJO 2/4DR
3674	481155	93-99 RANGER
3684	481160	91-95 DODGE MINIVANS
3724	481162	91-96 JEEP CHROKEE INCLUDES CNVRTR
3744	481163	84-00 TOYOTA PU(XCPT T-100)INCL CNVTR
3784	481165	95-PRESENT DODGE FS DAKOTA & RAM CHARGER
3794	481167	95-00 FORD EXPLORER, INCL PWR CNVRT
3804	481168	91-97 NISSAN PU (INCLUDES CONVERTOR)
3814	481171	94-98 TOYOTA T-100 PU
3824	481173	93-98 DODGE VAN (FULL SIZE)
3844	481190	93 JEEP GRAND CHEROKEE INCL PWR CNVRTR
3854	481195	94-98 JEEP GRAND CHEROKEE INCL CNVRT
3864	481200	96-00 CHRY MINIVANS, 98-PRESENT DURANGO, INCLUDES CONVERTER
3874	481205	95-98 FORD WINDSTAR (INCL CONV)
3884	481250	92-01 TROOPR, 96-99 ACURA SLX W/ CONV
3904	481260	95-PRESENT BLAZER, JIMMY, ASTRO, SAFARI, BRAVADA
3914	481265	96-97 FORD EXPLORER, MERCURY MOUNTAINEER
3934	481275	87-96 CHEVY/GM C FS VAN, EXCEPT EXPRESS
33515	481412	98-PRESENT NISSAN FRONTIER
31135	481625	98-PRESENT S10/S15 PU SONOMA, ISUZU HOMBRE
31365	481662	97-PRESENT CHEV/GMC VENTURE SIHOUTTE TRANSP
31325	481664	96-99 CHEV/GMC EXPRESS & SAVANNA VANS
30155	481712	99-PRESENT FORD F-250/350 SUPERDUTY
30915	481740	95-00 EXPLORER, 96-01 MOUNTAINEER, 98-99 RANGER W/ TOWPKG
30655	481748	95-PRESENT FORD VAN, 1997 AEROSTAR
30615	481762	99-PRESENT FORD WINDSTAR VAN
32465	481844	97-PRESENT JEEP CHEROKEE
32535	481845	99-PRESENT JEEP GRAND CHEROKEE
32315	481870	99-00 DODGE FULL SIZE VAN
32615	481882	98-PRESENT JEEP WRANGLER
33365	481910	99-00 TOYOTA TUNDRA
33215	481954	98-PRESENT ISUZU RODEO /HOMBRE, HONDA PASSPORT
6 & 7 Way Adapters		
3065	481475	ADAPTER PLUG, CONVERTS FLAT 4 WAY TO 6 WAY ROUND
3074	481500	ADAPTER PLUG, CONVERTS FLAT 4 WAY TO 7 WAY ROUND



## Vehicle-to-Trailer Wiring Systems

LiteMate® is the *quick* and *easy* way to wire trailer lights.

No more *stripping, splicing or taping.*

LiteMate® takes the work out of wiring a trailer to any car, truck or van, both domestic and import!

**For Connecting:** • Camping Trailers • Boat Trailers • Horse or Stock Trailers or any trailer!

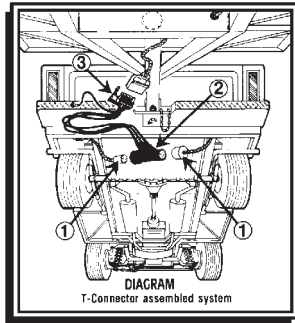

Diagram shows how LiteMateI® works on trucks that have a plug-in taillight connection... usually located just behind the rear bumper.

All you do is:

- (1) unplug that connector
- (2) plug the LiteMateI® "T" connector into the circuit
- (3) and into the trailer.

**THE WIRING IS NOW COMPLETE. IT'S THAT SIMPLE!**

## 2 Part Wiring System

### How It Works:

Most pickups have a molded connector that joins the wiring harness on the truck bed to the main wiring harness of the frame. This connector is located just behind the rear bumper.

- 1) Simply *pull apart this connector*
- 2) *insert the LiteMate®*
- 3) *plug it back together.*
- 4) Now *plug in the LiteMate® harness* that matches the connector on your trailer.

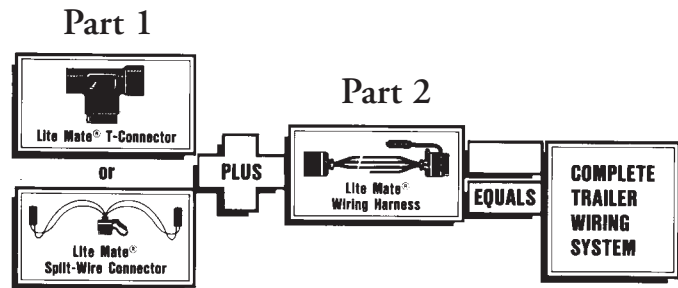

### How to Select a LiteMate® Trailer Wiring System:

1. Choose the LiteMate® Trailer Light Connector that fits your vehicle.
2. Select the LiteMate® Trailer Wiring Harness that matches your trailer (3-wire, 4-wire, 6-wire or 7-wire).

### Part 1: Vehicle "Tee" Connector

Note: For vehicles not specifically listed use 23115 or 24115.  
(See Previous Page for Late-model vehicle applications)

Part No.	Ref. No.	Description
20215	479800	FITS CHEVY PU/BLAZER/SUBURBAN TO 1984
23115	480160	FITS VEHICLES WITH RED TURN SIGNAL & 4 WIRE SYSTEM
24115	480175	FITS VEHICLES WITH AMBER TURN SIGNAL & 5 WIRE SYSTEM

### Part 2: Wiring Harness

Part No.	Ref. No.	Description
22715	480400	WIRING HARNESS W/ FLAT 4 WAY PLUG
20615	480600	WIRING HARNESS W/ 6 WAY ROUND CONNECTOR
20715	480800	WIRING HARNESS W/ PLASTIC 7 WIRE RV CONNECTOR

## Trailer Connector Adapters



ADP624



ADP724RV



ADP726RV

For towing trailers with flat 4-way or round 6-way plugs and vehicles using 6-way round or 7-way RV Socket. Simply plug into tow vehicle connector and connect to trailer.

Part No.	Ref. No.	Description
ADP624	477700	TRAILER CONNECTOR ADAPTER, CONVERTS 6-WAY ROUND RECEPTACLE TO FLAT 4-WAY PLUG
ADP724RV	478500	TRAILER CONNECTOR ADAPTER, CONVERTS 7-WAY RV RECEPTACLE TO FLAT 4-WAY PLUG
ADP726RV	478550	TRAILER CONNECTOR ADAPTER, CONVERTS 7-WAY RV RECEPTACLE TO 6-WAY ROUND PLUG

## Taillight Converters



Some of today's domestic and import vehicles have a new "3-wire" taillight system utilizing separate electrical circuits for turn signals and brake lights. This can cause a wiring problem when towing a trailer or being towed by a vehicle that has the conventional two-wire system. The Power Converter draws power for trailer lights directly from the battery protecting sensitive vehicle electronic systems.

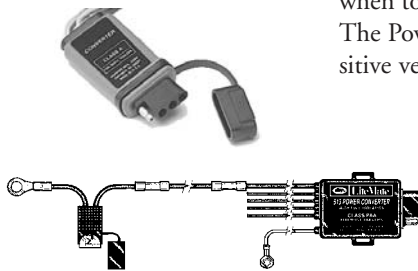

Part No.	Ref. No.	Description
TLC510	473500	3-WIRE TO 2-WIRE CONVERTER FOR TRAILER TOWING HAS BUILT-IN 4-WAY FLAT TRAILER CONNECTOR
TLC513	473515	POWER CONVERTER W/MOLDED FLAT 4 WAY, FITS MOST LATE MODELS

## Connector Brackets

The Steel Connector Brackets mount on the vehicle to secure the vehicle connector in place.

11-617



11-771

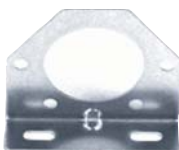

12-701



70985

Part No.	Ref. No.	Description
11-617	482000	CHROME BRACKET FOR CONNECTORS S602, S402
11-771	482200	CHROME BRACKET FOR CONNECTOR 11-720
12-701	482400	BLACK BRACKET FOR CONNECTOR 12-703, 12-707, TC78-004, TC78-007
70985	482600	CHROME BRACKET FOR "KNOCKOUT" CONNECTOR K04448

## Primary Wire

Standard copper Primary Wire is widely used in the trailer and automotive industry for original equipment and replacement wiring. The General Purpose Thermo-Plastic (GPT) Insulation is highly resistant to acids, gasoline, oil, grease and most industrial solvents. Meets SAE J1128 Specifications. For use with 50 volts or less, 176°F (80°C).



### 10 Gauge

#### 100 ft. Roll

Color	Part No.	Ref. No.
BLUE	10-1-100BE	456400
BLACK	10-1-100BK	456600
RED	10-1-100RD	456800

### 12 Gauge

#### 100 ft. Roll

#### 500 ft. Roll

Color	Part No.	Ref. No.	Part No.	Ref. No.
BLUE	12-1-100BE	455600	12-1-500BE	459800
BLACK	12-1-100BK	455800	12-1-500BK	460000
RED	12-1-100RD	456000	12-1-500RD	460200
WHITE	12-1-100WE	456200	12-1-500WE	460400

### 14 GAUGE

#### 100 ft. Roll

#### 500 ft. Roll

Color	Part No.	Ref. No.	Part No.	Ref. No.
BLUE	14-1-100BE	454200	14-1-500BE	458400
BLACK	14-1-100BK	454400	14-1-500BK	458600
BROWN	14-1-100BN	454600	14-1-500BN	458800
GREEN	14-1-100GN	454800	14-1-500GN	459000
RED	14-1-100RD	455000	14-1-500RD	459200
WHITE	14-1-100WE	455200	14-1-500WE	459400
YELLOW	14-1-100YW	455400	14-1-500YW	459600

### 16 GAUGE

#### 100 ft. Roll

#### 500 ft. Roll

#### 5,000 ft. Roll

Color	Part No.	Ref. No.	Part No.	Ref. No.	Part No.	Ref. No.
BLUE	16-1-100BE	452800	16-1-500BE	457000	16-1-5000BE	460410
BLACK	16-1-100BK	453000	16-1-500BK	457200	16-1-5000BK	460420
BROWN	16-1-100BN	453200	16-1-500BN	457400	16-1-5000BN	460430
GREEN	16-1-100GN	453400	16-1-500GN	457600	16-1-5000GN	460440
RED	16-1-100RD	453600	16-1-500RD	457800	16-1-5000RD	460450
WHITE	16-1-100WE	453800	16-1-500WE	458000	16-1-5000WE	460460
YELLOW	16-1-100YW	454000	16-1-500YW	458200	16-1-5000YW	460470

## Bonded Parallel Primary Wire

Parallel Primary Wire has two, three or four parallel conductors bonded together by Thermo-Plastic insulation, in flat ribbon configuration. Each conductor is independently color coded for easy identification. Meets SAE J1128 Specifications, for use with 50 volts or less, 176° F (80°C).

Part No.	Ref. No.	Gauge	Conductor	Roll Length	Colors
18-3B-100	460550	18	3	100 FT	YELLOW, BROWN, GREEN
18-3B-500	460600	18	3	500 FT	YELLOW, BROWN, GREEN
18-3B-2500	460650	18	3	2,500 FT	YELLOW, BROWN, GREEN
16-2B-100	460750	16	2	100 FT	RED, BLACK
16-2B-500	460800	16	2	500 FT	RED, BLACK
16-3B-100	460950	16	3	100 FT	YELLOW, BROWN, GREEN
16-3B-500	461000	16	3	500 FT	YELLOW, BROWN, GREEN
16-3B-2500	461100	16	3	2,500 FT	YELLOW, BROWN, GREEN
16-4B-100	461150	16	4	100 FT	YELLOW, BROWN, GREEN, WHITE
16-4B-500	461200	16	4	500 FT	YELLOW, BROWN, GREEN, WHITE
16-4B-1000	461210	16	4	1,000 FT	YELLOW, BROWN, GREEN, WHITE

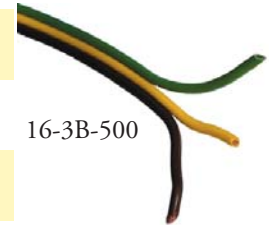

16-3B-500

## Jacketed Duplex Brake Wire

Duplex Brake Wire is made with two plastic insulated primary wires laid parallel and covered with a high quality plastic jacket, protecting the insulated conductors. Each conductor is color coded for easy identification. Meets SAE J1128 Specifications, for use with 50 volts or less, 221° F (105°C).

Part No.	Ref. No.	Gauge	Conductor	Roll Length	Colors
14-2-100	461350	14	2	100 FT	BLACK AND WHITE
14-2-500	461400	14	2	500 FT	BLACK AND WHITE
12-2-500	461600	12	2	500 FT	BLACK AND WHITE



14-2-100

## Insulated Lighting Cable

Plastic Trailer Cable is manufactured to SAE and ATA specifications. This multiconductor stranded copper wire maintains flexibility even though each conductor is insulated with a heavy vinyl covering. To provide an additional safety factor, the entire cable is enclosed in a black vinyl jacket to reduce road hazards from moisture, solvents, grease, oil, gasoline, abrasion, chemicals and weather. Conductors meet SAE J1128 Specifications, for use with 50 volts or less, 176° F (80°C).

Part No.	Ref. No.	Gauge	Conductor	Roll Length	Colors
164C500	461800	16	4	500 FT	BROWN, GREEN, RED, YELLOW
166C500	462000	16	6	500 FT	BLUE, BLACK, BROWN, GREEN, RED & YELLOW
144C500	462200	14	4	500 FT	BROWN, GREEN, RED, YELLOW
146C500	462400	14	6	500 FT	BLUE, BLACK, BROWN, GREEN, RED, YELLOW
127C500	462425	(6)12GA (1)10GA	7	500 FT	BLUE, BLACK, BROWN, GREEN, RED, YELLOW, WHITE



127C500



## Hardware

We make it our business to have the trailer parts you need when you need them and that means having a full line of hardware and accessories for you to choose from. As your one stop shop for hardware, we have hinges, handles, latches, rivets and drill bits. If that's not enough, we also have cargo straps, rollers, brackets, rubber mats, pad sets, floor screws and more!

Continuous Hinge	K-2	Torx Screwdriver Bit and Holder	K-11
Ramps and Ramp Springs	K-2	Torx Floor Screws	K-11
Spare Tire Carriers	K-2	Mud Flaps	K-12
Grab Handles and Steps	K-2	Molded Rubber Stall Mat	K-12
Towing Mirrors	K-2	Heavy-Duty Rubber Trailer/Stall Mat	K-12
Latches	K-3	Molded Trailer Accessories	K-12
Pin and Roller Assembly	K-3	Rubber Trailer Mats	K-12
Hinge Pins and Nipple	K-3	Horse Trailer Pads and Pad Sets	K-13
Flush Hinge	K-3	Rumber™ Stock Trailer Flooring	K-13
Cam-Door Lock	K-4	Pre-Drilled Rubber Bumpers	K-14
Door Handle & Keep	K-4	Rubber Bumpers	K-14
Vinyl Handle Grips	K-4	Rumber™ Trailer Liner	K-14
Latches	K-4	Strap Winches	K-15
Door Holders	K-5	Cargo Control Equipment	K-15
“Suitcase” Latch	K-5	Tie Down Straps	K-15
Cab Locks	K-5	Cargo Control Products	K-15
Chain Protectors	K-6	Tarp Straps	K-16
D-Rings and Lashing Rings	K-6	Wheel Nets	K-16
Tie Loops	K-6	Axle Straps	K-16
Stake Pockets	K-6	Winch Straps	K-16
Redline Packaged Hardware	K-7	Kinedyne E-Track Cargo Control	K-17
Chain Load Binder	K-8	Bolster and Bunk Brackets	K-17
Hooks	K-8 - K-9	U-Bolts	K-17
Safety Chains	K-8 - K-9	Roller Brackets	K-18
S-Hooks, Quick Links and Spring Links	K-9	Rubber Bow Guards	K-18
Pop Rivets	K-10	Rubber Side Guide Roller and Cap	K-18
Pop Rivet Tool	K-10	Roller Shaft and Pal Nuts	K-18
Drill Bits	K-11		

## Towing Mirrors



The durable all black towing mirror is fully adjustable and fits most standard OEM mirrors. The jointed extension arms adapt to the desired angle or shape, and the mirror head pivots on a ball so it can be used either vertically or horizontally. Easily installed with no tools; just clip the mirror on and cinch up straps until they are tight. When mirror is not in use it is collapsible so it takes up very little storage space.

Part No.	Ref. No.	Description
30-0096XL	413330	CLIP ON TOWING MIRROR
30-0098RS	413325	REPLACEMENT STRAPS FOR CLIP ON TOW MIRROR

## Grab Handles and Steps

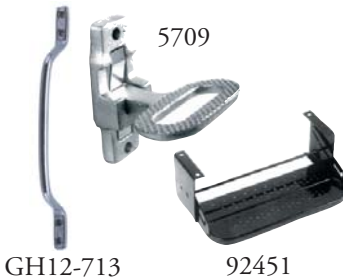

Folding steps are excellent for use on trucks, trailers and campers. The folding step assures a dependable hand hold or foot rest. The #5709 folding step is constructed of heavy iron with a stainless steel spring. The #92451 pullout step is ideal for campers and other step-up trailers. The pullout step extends out and down when in use and pushes up and in to be out of sight when traveling.

Part No.	Ref. No.	Description
GH12-713	376990	GRAB HANDLE, STEEL W/ CHROME FINISH 2" X 13"
5709	382800	STEP PAD, BACK PLATE 2" x 2", STEP PAD 2 1/8" x 4 3/8"
92451	383000	PULL OUT STEP SIZE 7" x 20" WITH 8" DROP

## Spare Tire Carriers



Part No.	Ref. No.	Wheel Bolt No.	Description
6220	412800	4,5	HAS EXTRA LENGTH TO ALLOW THE HANDLING OF WIDE TIRES OR WILL SPAN THE WIDER TONGUES OF CUSTOM BUILT TRAILERS, PACKAGED
6280	413000	4,5	WITH PADLOCK, ADDS EXTRA PROTECTION TO KEEP YOUR SPARE TIRE IN PLACE, PACKAGED
STC7564	413100	4,5	HI-MOUNT FITS UP TO 3" X 4" SO. TONGUE (COMES WITH MOUNTING HARDWARE), BOXED
8650	413200	5,6,8	COMMONLY USED ON HORSE AND LIVESTOCK TRAILERS

## Ramps and Ramp Springs



We offer several devices that can be used to assist in getting wheeled cargo into the trailer or truck bed. Wood planks are not included on #RE8T.

Part No.	Ref. No.	Description
RE8T	385610	FULTON RAMP ENDS, TOPS ONLY (1 SET)
R69-BI	385650	FULTON RAMP SET, BI-FOLD ALUMINUM, 1000LB CAP
RS16933LH	385700	RAMP SPRING LEFTHAND 2K TORQUE FOR 1 1/2" SHAFT
RS16933RH	385705	RAMP SPRING RIGHTHAND 2K TORQUE FOR 1 1/2" SHAFT

## Continuous Hinge

Also called a "piano hinge", Continuous Hinges can be used in many applications. All hinges rotate 270 degrees, measure 6 ft. in length, and come with no holes.



Part No.	Ref. No.	Flat Width	Pin Size	Gauge	Knuckle Length	Material Type
H150	383800	1 1/2"	1/8"	.050"	1/2"	MILD STEEL
SH150	383820	1 1/2"	1/8"	.050"	1/2"	STAINLESS STEEL
H200	384000	2"	3/16"	.060"	1/2"	MILD STEEL
SH200	384020	2"	3/16"	.060"	1/2"	STAINLESS STEEL
H300	384200	3"	1/4"	.074"	1"	MILD STEEL
SH300	384220	3"	1/4"	.074"	1"	STAINLESS STEEL



## Chrome Flush Hinge

Commonly known as a "Refrigerator Door Hinge", this chrome plated zinc die-cast unit utilizes a 5/16" stainless steel pin for increased rust resistance, and pivots on two nylon bushings for smooth operation. Mounts with six - No.10 flat or oval head screws (not included).



Part No.	Ref. No.	Width	Length
104	383700	3 1/4"	6"

## Hinge Pins and Nipple

Used for custom building your own heavy duty door hinges, Hinge Pin Nipples are welded to outer frame and to door, aligning them so the Hinge Pin may be inserted. Greasable hinge pins have a grease zerk installed on one end and an outlet hole to allow lubrication of the hinge.

Part No.	Ref. No.	Description	Diameter	Length
HPN214	384375	HINGE PIN NIPPLE	1/2" I.D.	2 1/4"
HP412	384378	HINGE PIN	1/2" O.D.	4 1/2"
HP412G	384381	HINGE PIN, GREASABLE	1/2" O.D.	4 1/2"
HP634	384384	HINGE PIN	1/2" O.D.	6 3/4"
HPN34-214	384387	HINGE PIN NIPPLE	3/4" I.D.	2 1/4"
HP34-412G	384390	HINGE PIN, GREASABLE	3/4" O.D.	4 1/2"
HPN34-2	384395	HINGE PIN NIPPLE	3/4" I.D.	2"
HP34-4G	384397	HINGE PIN, GREASABLE	3/4" O.D. X 1" BASE	4"



HPN214



HP412G

## Pin and Roller Assembly

For sliding gates and doors, or anywhere a small wheel is needed. Available in rubber with nylon insert or all steel construction.

Part No.	Ref. No.	Description	I.D.	O.D.	Width	Pin. Dim.
RL11265ND4	381025	RUBBER ROLLER WHEEL	1/4"	2"	7/8"	NO PIN
PRA-1	381000	STEEL ROLLER WHEEL	1/2"	1 1/2"	7/16"	1/2" X 1 3/4"



## Flush Latches

Flush Latches feature a Stainless Steel Spring, with or without Locking Cylinders. Available with Plain (rust-proofed) coated steel or Stainless finish ensuring long life and trouble free service.

Part No.	Ref. No.	Description	Type	Finish	Hole Size
L1980	379000	LOCKING	"JUNIOR"	PLAIN	2 3/4" x 3 3/4"
N1980	379200	NON-LOCKING	"JUNIOR"	PLAIN	2 3/4" x 3 3/4"
L1930	379400	LOCKING, INSIDE RELEASE	"JUNIOR"	PLAIN	2 3/4" x 3 3/4"
L1883	379600	LOCKING	"JUNIOR"	STAINLESS	2 3/4" x 3 3/4"
L1833	379800	LOCKING, INSIDE RELEASE	"JUNIOR"	STAINLESS	2 3/4" x 3 3/4"
L4080	380230	LOCKING	T-HANDLE	STAINLESS	2 3/4" x 3 3/4"
L3980	380000	LOCKING	FULL SIZE	PLAIN	3 3/8" x 4 5/8"
N3980	380200	NON-LOCKING	FULLSIZE	PLAIN	3 3/8" x 4 5/8"
CHK510	380250	REPLACEMENT KEY #510			
CHK545	380275	REPLACEMENT KEY #545			
CHKT	380600	REPLACEMENT KEY AND TUMBLER SET FOR LOCKING "JUNIOR" FLUSH LATCHES			



L1883



L1980



L4080

## Tipper Latch

Tipper Latches are commonly used for tilt-bed utility, snowmobile and boat trailers. They are spring loaded for easy release.

Part No.	Ref. No.	Description
382	413400	TIPPER LATCH

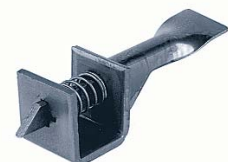

## Latches

Rear Door Latch for stock trailers includes a steel bar, handle and catch. For a complete assembly use 2 sets with Hinge Pins, Nipples and Flat Vinyl Handle Grips (#FVH200).

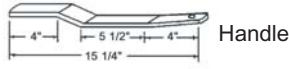

Handle



Strap

Part No.	Ref. No.	Description
312LS	380800	3 -PIECE SET
312LS-H	380805	REPLACEMENT HANDLE FOR 312LS
312LS-C	380810	REPLACEMENT CATCH FOR 312LS
312LS-S	380815	REPLACEMENT STRAP FOR 312LS

## Spring Latch

Spring Latch features stainless steel spring, 7 5/16" long pin with looped handle and mounting hole centers of 1" x 1 7/8". Custom requests can be accommodated if your requirements differ.



Part No.	Ref. No.	Pin Size	Finish
SL716	380700	7/16"	ZINC
SL716SS	380725	7/16"	STAINLESS W/ ALUMINUM BASE

## Vinyl Handle Grips

The black Vinyl Handle Grips fit over stock trailer door handles and latches or anywhere else a finishing touch is desired.



Part No.	Ref. No.	Type	Inside Dimension	Length
FVH150	384400	FLAT	1/4" x 1 1/2"	3"
FVH200	384600	FLAT	1/4" x 2"	3"
RVH50-1	384850	ROUND	1/2"	1"
RVH50	384800	ROUND	1/2"	4"
RVH60	385000	ROUND	9/16"	4"
RVH75	385200	ROUND	3/4"	4"

## Door Handle & Keeper

Designed for Horse/Stock Trailers. All Handles are 9/16" rod and can be used with our Round Vinyl Grips (#RVH60).

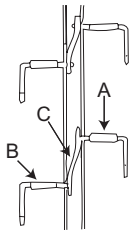

Part No.	Ref. No.	Description	Item
DHR10	381800	RIGHT DOOR LATCH	A
DHL10	382000	LEFT DOOR LATCH	B
DKH10	382200	LATCH KEEPER	C

## Universal Cam-Door Lock

This plain-finish Cam-Lock is for all van bodies, trucks and trailers. It is ideal for side door applications. The Lock can be installed on flush to 3/4" offset doors. A bridge-type Keeper prevents accidental opening and ensures safe locking action. The positive double action handle gives dual protection against jarring in transit.

Measurements:

- 3/16" Thick Bearing Covers
- 1 3/4" Maximum Lock Protection
- 1/2" Square Padlock or Seal Eye
- 1 7/8" Width of Keeper
- 13/52" Diameter Mounting Holes



Part No.	Ref. No.	Description
5654X	383200	CAM-DOOR LOCK, USES 3/4" I.D. PIPE (NOT SUPPLIED)
158-100	383225	REPLACEMENT HANDLE FOR 5654X
158-101	383250	REPLACEMENT HANDLE LATCH FOR 5654X

## Cab Lock Handles

Available in locking or non-locking models, the door/compartament Handles are designed for use with Cab Locks. All shafts are 5/16" square.

Part No.	Ref. No.	Description	Shaft Length
276	377000	"L" HANDLE WITH LOCK	2 1/2"
277	377200	"L" HANDLE WITHOUT LOCK	2 1/2"
777	377400	"T" HANDLE WITH LOCK	2 1/4"
818-20	377600	ADJUSTABLE LATCH, USED IN PLACE OF CAB LOCK	



## Cab Locks

The Cab Locks are surface-mounted to the door so no mortising or blocking is required for installation. They are fitted with a high-carbon tempered flat steel spring for smooth operation and a die-formed bushing. The 2" wide, 3 3/8" tall Locks are to be used with the #276 and #277 "L" and #777 "T" handles.

Part No.	Ref. No.	Description
57LH	378200	LEFT HAND WITH THUMB RELEASE
57RH	378400	RIGHT HAND WITH THUMB RELEASE
58LH	378600	LEFT HAND WITHOUT THUMB RELEASE
58RH	378800	RIGHT HAND WITHOUT THUMB RELEASE



## "Suitcase" Latch

The over-center latch with a high strength wire loop provides the greatest holding power of all loop configurations. Features zinc plating and firm draw up tension for secure holding.

Part No.	Ref. No.	Description	Length	Width
HC207	382400	WITH LOCK HOLE	3 13/16"	1 9/32"
HC210	382600	WITHOUT LOCK HOLE	3 13/16"	1 9/32"
HC207-L/K	382405	REPLACEMENT CATCH W/LOCK HOLE FOR HC207		
HC210-L/K	382605	REPLACEMENT CATCH W/O LOCK HOLE FOR HC210		
HC205ZE	382425	REPLACEMENT STRIKE FOR HC207 & HC210		



## Door Holders

One part is mounted to the door, the other to the side of the trailer. Used to hold the door open. Zinc plated metal.

Part No.	Ref. No.	Description
5601	383400	HOOK AND KEEPER
DH100	383600	PLUNGER & RUBBER SOCKET ( 2 5/8" OVERALL)
DH100S	383610	REPLACEMENT RUBBER SOCKET FOR DH100
DH100P	383620	REPLACEMENT PLUNGER FOR DH100 (2 1/4" LENGTH)
DH604	383630	PLUNGER & NYLON SOCKET (1" STEM)
DH604P	383635	REPLACEMENT PLUNGER FOR DH604 (1" LENGTH)
DH605	383640	PLUNGER & NYLON SOCKET (2" STEM)
DH605P	383645	REPLACEMENT PLUNGER FOR DH605 (2" LENGTH)
DH600S	383650	REPLACEMENT NYLON SOCKET FOR DH604 & DH605
DH38R	383675	1" PLASTIC STEM & RUBBER SOCKET
DH38S	383680	RUBBER SOCKET FOR DH38R & DH39R
DH38P	383685	1" PLASTIC STEM FOR DH38R
DH39R	383690	2" PLASTIC STEM & RUBBER SOCKET
DH39P	383695	2" PLASTIC STEM FOR DH39R



## Weld-on Stake Pockets



For use on truck or trailer flat beds. Designed to accept standard 2" x 4" stakes.

Part No.	Ref. No.	Gauge	Height	I.D.
STKP34	404625	4	3"	1 5/8" X 3 1/2"

## Tie Loops

Tie Loops can be used wherever a rope-tie or halter-tie is desired. Choose from brushed aluminum bolt-on, or conventional weld-on styles.



TL20012AB

Part No.	Ref. No.	Description	Diameter	Inside Diameter	Leg Length
TL20012AB	385350	ALUMINUM, BOLT-ON ROUND	1/2"	2"	2 1/4"
TL20012	385400	METAL, WELD-ON ROUND	1/2"	2"	2"
TL21438	385600	METAL, WELD-ON SQUARE	3/8"	2 1/4"	7/8"

## D-Rings and Lashing Rings

A full range of sizes of D-Rings and Lashing Rings are available; light duty for rope ties in cargo and horse/stock trailers and heavy duty for chains, etc. on equipment/flat bed trailers.



DR14-15



DR14-20



DR14-30



DRB12-25



DR58-3



RDR801



DR10-3-4



RDR901

Part No.	Ref. No.	Capacity	Description
DR14-15	404150	N/R	1/4" W/BOLT-ON MOUNTING BRACKET MEASURES 1 1/8" x 1 1/8" I.D. W/1 3/8" HOLES CENTERS ON BRACKET
DR14-20	404200	N/R	RECESSED ZINC-PLATED W/OVERALL MEASUREMENTS OF 5" LONG, 3 1/2" WIDE AND 3/8" DEEP
DR14-30	404245	N/R	4 1/5" O.D. SURFACE MOUNT W/ PLASTIC TRIM. ZINC PLATED.
DRB12-25	404300	4,000 WLL 12,000 MBS	1/2" W/BOLT-ON MOUNTING BRACKET MEASURES 2 1/2" X 2 3/8" I.D. W/2" HOLE CENTERS ON BRACKET
DR58-3	404400	6,000 WLL 19,000 MBS	5/8" DROP FORGED STEEL 3" x 3" I.D., WITH WELD-ON MOUNTING BRACKET
DR10-3-4	404600	15,000 WLL 47,000 MBS	1" DROP FORGED STEEL, 3" x 4" I.D., WITH WELD-ON MOUNTING BRACKET
RDR801	404605	6,000 LB RATED	4 1/2" X 4 7/8" O.D. RECESSED BRACKET, W/ 1 3/8" I.D. FORGED RING
RDR901	404610	6,000 LB RATED	6 1/5" O.D. RECESSED RING SWIVELS 360°. ZINC PLATED

NOTE: WLL = Working Load Limit; MBS = Minimum Breaking Strength

## Chain Protectors

"Rubatex" Foam Rubber easily slips over all sizes of chain. Prevents paint chipping, eliminates noisy chain rattle on gates and doors, and helps prevent injury to livestock.



Part No.	Ref. No.	Inside Diameter	Length
RT78	403900	7/8"	6FT
RT118	403905	1 1/8"	6FT
RT138	403910	1 3/8"	6FT

## Redline Packaged Hardware



### Packaged Chain & Rope Hardware

Part No.	Ref. No.	Description
HW01-005	398910	Safety chain hook, 3/8", 3K cap.
HW01-010	398912	Safety chain hook, 7/16", 5k cap.
HW01-015	398914	S-Hook, 1/4"
HW01-020	398916	S-Hook, 5/16"
HW01-025	398918	S-Hook, 3/8"
HW01-030	398920	Clevis slip hook, 1/4"
HW01-035	398922	Clevis slip hook, 5/16"
HW01-040	398924	Clevis slip hook, 3/8"
HW01-045	398926	Clevis grab hook, 1/4"
HW01-050	398928	Clevis grab hook, 5/16"
HW01-055	398930	Clevis grab hook, 3/8"
HW01-060	398932	Chain quick link, 3/16"
HW01-065	398934	Chain quick link, 5/16"
HW01-070	398936	Chain quick link, 3/8"
HW01-075	398938	Snap hook, open end, 5/8"
HW01-080	398940	Snap hook, swivel eye, 7/8"
HW01-085	398944	Winch strap hook
HW01-090	398948	Snap hook, double end, 1/4"



### Packaged Trailer Body Hardware

Part No.	Ref. No.	Description
HW03-010	404021	Aluminum tie loop, bolt-on
HW03-020	404022	D-Ring, surface mount, bolt-on
HW03-030	404023	D-Ring, recessed, bolt-on, plated
HW03-040	404024	D-Ring, surface plate mount
HW03-050	404025	D-Ring, surface mount, bolt-on
HW03-060	404026	D-Ring, surface mount, weld-on
HW03-070	404030	D-Ring, recessed, bolt-on, plated
HW03-080	404035	Stake pocket, weld-on
HW03-090	404045	Tipper latch
HW03-100	404050	Folding step/handle, bolt-on

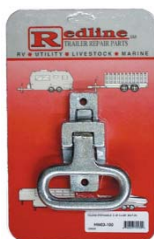

### Benefits of Redline Packaged Products

- Increased sales through:
  - impulse purchases
  - higher per unit selling price
- Less inventory shrinkage:
  - better product identification
  - reduced theft
- More efficient retail operations:
  - applications on package
  - UPC bar codes
  - improved product identification
- Fewer returns due to incorrect product selection
- Genuine OEM Components

### Trailer Door Hardware

Part No.	Ref. No.	Description
HW05-010	376961	L style door handle
HW05-020	376962	"T" style door handle
HW05-030	376964	Door handle cam
HW05-040	376966	Locking paddle latch, "JR"
HW05-050	376968	Locking paddle latch, full size
HW05-060	376970	Locking T-handle latch
HW05-070	376972	Draw latch
HW05-080	376974	Cast chrome hinge
HW05-090	376976	Door hold-back, hook/keeper
HW05-100	376978	Door hold-back, 2-18" stem
HW05-110	376980	Door hold-back, 1-1/2" stem
HW05-120	376982	Door hold-back, 2-1/2" stem
HW05-130	376984	Rubber door bumper, 1" dia.
HW05-140	376986	Rubber door bumper, 13/16" dia.



## Safety Chains



SAE Code J684, Section 6.3.1 reads: "Two lengths of Safety Chain or equivalent shall be used. They shall be connected from the opposite sides of the trailer tongue to the towing vehicle and when passing forward to the towing vehicle, shall be crossed under the trailer tongue in such a manner that they will cradle the trailer coupling and tongue in the event of separation of the coupling or ball." **For Proper Compliance,** we recommend the use of two Safety Chains or two Safety Cables attached at two separate points to the trailer.

## Safety Chains and Cables

Safety Chains provide additional assurance by securing the trailer to the tow vehicle. CC4-36 Cable is made of 1/4" diameter galvanized steel cable and has a 7,000 lb. Minimum Breaking Strength. A permanent coiled effect keeps the cable tight and prevents it from dragging.

SC1448



CC4-36

SC3835

Part No.	Ref. No.	Description	Diameter	Overall Length	Class	Min. Breaking Strength
CC4-36	393300	CABLE W/7/16" HOOK ONE END & BOLT LOOP ON THE OTHER	1/4"	36"	III	7,000 LB
SC31648	393400	3/8" HOOKS BOTH ENDS	3/16"	48"	I	3,000 LB
SC31627	393500	3/8" HOOK ONE END	3/16"	27"	I	3,000 LB
SC1448	393600	7/16" HOOKS BOTH ENDS	1/4"	48"	III	5,000 LB
SC1427	393800	7/16" HOOK ONE END	1/4"	30"	III	5,000 LB
SC3835	393900	CLEVIS SLIP HOOK ONE END	3/8"	35"	*	15,000 LB
SC71637	393950	CLEVIS SLIP HOOK ONE END	7/16"	37"	*	25,000 LB
TA06-100	394050	RUBBER SAFETY CHAIN KEEPER				

## Safety Chain S-Hooks

Our Safety Chain Hooks are made of high test steel alloy and bright zinc plated to assure dependability and strength. Two sizes are available.



Part No.	Ref. No.	Hook Diameter	Chain Size	Class	Working Load Limit	Min. Breaking Strength
4380	401200	11/32"	3/16"	I & II	1,037 LB	3,000 LB
4480	401225	7/16"	1/4"	III	1,430 LB	5,000 LB

## Clevis Grab and Clevis Slip Hooks

These heat treated, electro-zinc plated Clevis Grab and Clevis Slip Hooks meet all requirements for Grade 43 High Test Chain. This versatile design finds many uses in industry or on the farm.

**DO NOT** use these Hooks for overhead lifting and do not exceed the working load limit.



Part No.	Ref. No.	Size	Type	Working Load Limit	Min. Break Strength
450-0424	400600	FOR 1/4" CHAIN	GRAB	2,600 LB	7,800 LB
450-0524	400800	FOR 5/16" CHAIN	GRAB	3,900 LB	11,700 LB
450-0624	401000	FOR 3/8" CHAIN	GRAB	5,400 LB	16,200 LB
14CHOOK	401140	FOR 1/4" CHAIN	SLIP	2,600 LB	7,800 LB
516CHOOK	401160	FOR 5/16" CHAIN	SLIP	3,900 LB	11,700 LB
385CHOOK	401180	FOR 3/8" CHAIN	SLIP	5,400 LB	16,200 LB

## Chain Load Binders

Rated to high test chain specifications, the drop forged Chain Load Binders have free-turning 360 degree swivels on both hooks allowing for easier handling and hook-up. Meets or exceeds CVSA cargo securement guidelines. Part 52003 is ratchet type.



Part No.	Ref. No.	Max. Size Chain (Grade 43)	Min. Breaking Strength	Working Load Limit
48312	396200	1/4"	7,800 LBS	2,600 LB
52003	396300	3/8"	19,000 LBS	5,400 LB
48313	396400	3/8"	19,000 LBS	5,400 LB

## Grade 30 Proof Coil Chain

An excellent general purpose Chain for use as tow chains, binding, or tie-down chains and logging chains. Proof Coil is **NOT** to be used for overhead lifting. Proof Coil Chain is Grade 30 low carbon steel with electro-galvanized zinc finish and comes in a 5 gallon plastic pail.

Part No.	Ref. No.	Size	Working Load Limit	Length	Min. Breaking Strength
316ZPC	394200	3/16"	800 LBS	250 FT	3,200 LB
14ZPC	394600	1/4"	1,300 LBS	141 FT	5,200 LB
516ZPC	395200	5/16"	1,900 LBS	92 FT	7,600 LB
38ZPC	395800	3/8"	2,650 LBS	63 FT	10,600 LB



## Grade 43 High Test Chain

High Test Chain is used in the same applications as Proof Coil Chain but has double the safe working load. High test chain is **NOT** to be used for overhead lifting. High Test Chain is Grade 43 low carbon steel, self-colored and comes in a 5 gallon plastic pail.

Part No.	Ref. No.	Size	Working Load Limit	Length	Min. Break Strength
14HTC	394800	1/4"	2,600 LBS	150 FT	7,800 LB
516HTC	395400	5/16"	3,900 LBS	90 FT	11,700 LB
38HTC	396000	3/8"	5,400 LBS	75 FT	16,200 LB



## Snap Hooks

The Snap Hook is designed for quick connecting and disconnecting of light duty chain, cable and rope assemblies. All are plated for rust protection. (Snap hooks are not rated.)

Part No.	Ref. No.	Description	Length	Eye Diameter
162S	402800	DOUBLE END BOLT SNAP	3 1/2"	5/8"
225	403000	SWIVEL BOLT SNAP	3 1/2"	5/8"
231	403200	OPEN EYE BOLT SNAP	3 1/2"	5/8"
466	403600	SNAP HOOK	3 1/2"	5/8"



## S-Hooks, Quick Links and Spring Links

The S-Hook is a quick, easy way to connect chains and is constructed of high alloy steel with a zinc plated finish. Quick Links are for a quick connection of chain, cable and wire rope, and can be hand tightened.

Part No.	Ref. No.	Diameter	Type	Inside Length	Working Load Limit	Min. Breaking Strength
610-6024	399000	3/16"	S-HOOK	1 13/16"	117 LBS	351 LB
610-8024	399200	1/4"	S-HOOK	1 25/32"	189 LBS	567 LB
610-1024	399400	5/16"	S-HOOK	2 1/4"	323 LBS	1,292 LB
610-1224	399600	3/8"	S-HOOK	2 3/8"	428 LBS	1,284LB
750-3203	399800	3/16"	Q-LINK	1 5/8"	616 LBS	2,640 LB
750-3204	400000	1/4"	Q-LINK	1 3/4"	880 LBS	3,520 LB
750-3205	400200	5/16"	Q-LINK	2 1/4"	1,540 LBS	6,160 LB
750-3206	400400	3/8"	Q-LINK	2 1/3"	1,900 LBS	7,600 LB
750-3207	400450	1/2"	Q-LINK	3 1/3"	3,300 LBS	10,600 LB
380-4410	400500	5/16"	SPRING LINK	2 1/2"	350 LBS	N/R
380-4425	400525	3/8"	SPRING LINK	3 1/8"	425 LBS	N/R

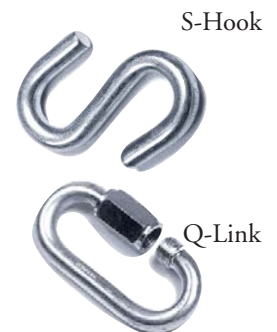

Spring Link

## Pop Rivet Tool



This is a best selling hand rivet tool in the industry. Features a square shoulder fulcrum pin of cold-formed heat-treated steel to prevent pin rotation that can elongate the engaging holes and cause premature tool failure in imitation tools. Other quality features include: precision die-cast, high-strength aluminum alloy body, drop-forged carbon steel upper handle and thick, cushion-molded vinyl grips for comfort. Sets up to 3/16" steel rivets and comes with four mounted nosepieces (3/32", 1/8", 5/32", and 3/16") and a service wrench.

Part No.	Ref. No.	Description
39000	495600	HEAVY-DUTY HAND RIVETER

## Pop Rivets

Determine which Rivet you need for the job by the grip range. Rivets are designed to provide the best fastening when used within the proper grip range. If the thickness of the material you are fastening varies, it is best to use more than one size rivet.

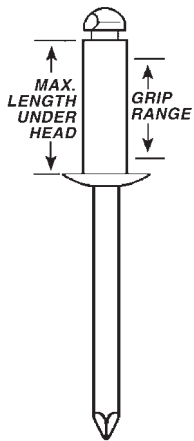

Part No.	Ref. No.	Rivet Diameter / Flange Diameter	Hole Size Drill No.	Max. Length Under Head	Grip Range (Inches)	Quantity
AD42ABS	386800	1/8"	.129 - .133, 9/64"	.265	.032 - .125	500
AD44ABS	387000	1/8"	.129 - .133, 9/64"	.390	.188 - .250	500
AD45ABS	387200	1/8"	.129 - .133, 9/64"	.453	.251 - .312	500
AD46ABS	387400	1/8"	.129 - .133, 9/64"	.515	.313 - .375	500
AD46ABS-10M	387500	1/8"	.129 - .133, 9/64"	.515	.313 - .375	10,000
AD48ABS	387600	1/8"	.129 - .133, 9/64"	.640	.376 - .500	500
AD54ABS	387700	5/32"	.160 - .164, 11/64"	.465	.188 - .250	500
AD56ABS	387800	5/32"	.160 - .164, 11/64"	.540	.251 - .375	500
AD64ABS	388200	3/16"	.192 - .196, 13/64"	.440	.126 - .250	500
AD64ABSLF	388400	3/16" *	.192 - .196, 13/64"	.440	.126 - .250	500
AD66ABS	388600	3/16"	.192 - .196, 13/64"	.565	.251 - .375	500
SD66ABS	388700	STEEL 3/16"	.192 - .196, 13/64"	.565	.251 - .375	500
AD66ABSLF	388800	3/16" *	.192 - .196, 13/64"	.565	.251 - .375	500
AD68ABS	389000	3/16"	.192 - .196, 13/64"	.690	.376 - .500	500
AD610ABS	389200	3/16"	.192 - .196, 13/64"	.815	.501 - .625	500
AD610ABSLF	389400	3/16" *	.192 - .196, 13/64"	.815	.501 - .625	500
AD612ABS	389600	3/16"	.192 - .196, 13/64"	.940	.626 - .750	500
AD612ABSLF	389800	3/16" *	.192 - .196, 13/64"	.940	.626 - .750	500

\* Features 5/8" diameter large flange rivet head



## Torx Floor Screws

Torx Screws are the quick, easy and economical way to secure wood floors to trailers. Screws are 1/4" diameter, type "F" flat head and feature self-tapping screw points. They require a 7/32" pilot hole.

Part No.	Ref. No.	Diameter	Length	Head
TFX150	386200	1/4"	1 1/2"	FLAT
TFX225	386400	1/4"	2 1/4"	FLAT
TFX250	386600	1/4"	2 1/2"	FLAT
TF01-150	386250	PACKAGED FLOOR SCREWS, 1/4" X 1 1/2", (QTY 40)		
TF01-225	386450	PACKAGED FLOOR SCREWS, 1/4" X 2 1/4", (QTY 40)		
TF01-250	386650	PACKAGED FLOOR SCREWS, 1/4" X 2 1/2", (QTY 40)		



## Torx Screwdriver Bit and Holder

The Torx Screw Driver Bit has a 1/4" hex drive and makes installing Torx screws a simple task. For easier, faster floor screw installation, we now offer a 1/4" Hex Driver Bit holder for our TX430 floor screw bit. The driver bit is held securely in the holder by an internal ring retainer. The extended driver shaft can be mounted in any type drill chuck, making it easy to change torx bits and install floor screws.

Part No.	Ref. No.	Description
TX430-3	489205	TORX SCREW DRIVER BIT (PKG OF 3)
TX490	489210	1/4" TORX SCREW BIT HOLDER (DRIVER BIT NOT INCLUDED)

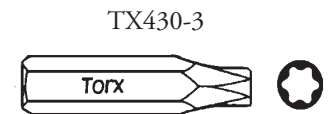

TX490

## Highspeed Twist Drill Bits

- Made in USA
- 135 degree Split Point for Accurate Centering and Fast Penetration
- Surface Treated for Abrasion Resistance and Rapid Chip Removal
- Package of 12 (38JB - Package of 6)

Jobber Length				
Part No.	Ref. No.	Fraction Size	Overall Length	Twist Length
18JB	486000	1/8"	2 3/4"	1 5/8"
532JB	486400	5/32"	3 1/8"	2"
1164JB	486600	11/64"	3 1/4"	2 1/8"
316JB	486800	3/16"	3 1/2"	2 5/16"
1364JB	487000	13/64"	3 5/8"	2 7/16"
732JB	487400	7/32"	3 3/4"	2 1/2"
14JB	487600	1/4"	4"	2 3/4"
38JB	488000	3/8"	5"	3 5/8"

Stubby Length				
Part No.	Ref. No.	Fraction Size	Overall Length	Twist Length
18SB	488200	1/8"	1 7/8"	7/8"
964SB	488400	9/64"	1 15/16"	15/16"
532SB	488600	5/32"	2 3/16"	1"
1164SB	488625	11/64"	2 1/8"	1 1/16"
316SB	489000	3/16"	2 3/16"	1 1/8"
1364SB	489050	13/64"	2 1/4"	1 3/16"
732SB	489100	7/32"	2 3/8"	1 1/4"



## Molded Trailer Accessories



4461-8



9901-0



2002MBT

Manufactured from patented Rumber®, a composite of recycled tire rubber and plastics. Fracture and shatter resistant from -40° F to over 100° F. Will not corrode and will not rot.

Part No.	Ref. No.	Description
9901-0	376950	RUMBER SADDLE RACK, BLACK
2002LBT	376956	RUMBER BRUSH TRAY, LARGE, 6"x7"x27 1/4"
2002MBT	376954	RUMBER BRUSH TRAY, MEDIUM, 6"x7"x17"
4461-8	376952	RUMBER BRIDLE HOOK (8), 4"x29 1/4"

## Rubber Trailer Mats



Flat Mat

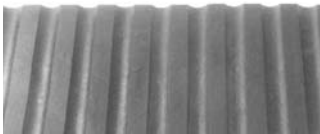

Ribbed Mat

Rubber Trailer Mats are used on floors, walls and dividers. The advantages of rubber mats are many: lessens sore legs, reduces swollen hocks, a nonporous surface reduces odors, easy to clean, reduces moisture in hot weather, dust in dry, and acts as good insulation from cold and sound.

Part No.	Ref. No.	Thickness	Type Mat	Dimensions	Packaged
30408MM	375300	8MM	FLAT	30" x 40'	ROLL
36408MM	375325	8MM	FLAT	36" x 40'	ROLL
48408MM	375375	8MM	FLAT	48" x 40'	ROLL
2822RM	375380	5/16"	RIBBED	28" x 22'	ROLL
3422RM	375385	5/16"	RIBBED	34" x 22'	ROLL
3622RM	375395	5/16"	RIBBED	36" x 22'	ROLL

## Heavy-Duty Rubber Trailer/Stall Mat

Provides the same benefits as our Rubber Trailer Mat sold above, but is thicker for better comfort and shock absorption. Can be used in both trailers and barn stalls.



Part No.	Ref. No.	Thickness	Type Mat	Dimensions	Packaged
4872SMF	376835	1/2"	SMOOTH	48" X 72"	SHEET
4884SMF	376840	1/2"	SMOOTH	48" X 84"	SHEET
6084SMF	376845	1/2"	SMOOTH	60" X 84"	SHEET
3484SM	376805	1/2"	GROOVED	34" X 84"	SHEET
3684SM	376810	1/2"	GROOVED	36" X 84"	SHEET
4872SM	376850	1/2"	RIBBED	48" X 72"	SHEET
6084SM	376852	1/2"	RIBBED	60" X 84"	SHEET
4872SM78	376855	3/4"	SMOOTH	48" X 72"	SHEET
6084SM78	376875	3/4"	SMOOTH	60" X 84"	SHEET

## Molded Rubber Stall Mat



Top Surface

Bottom Surface

Molded Stall mat is made of virgin rubber, has a treadplate pattern on top to increase footing stability, and a block pattern on bottom to increase surface adhesion.

**Not intended for trailer use.**

Part No.	Ref. No.	Thickness	Type Mat	Dimensions	Packaged
4872M	376880	APPROX. 1/2"	TREADPLATE	48" X 72"	SHEET
6084M	376890	APPROX. 1/2"	TREADPLATE	60" x 84"	SHEET

## Mud Flaps

These sturdy Mud Flaps are constructed of nylon cord, reinforced rubber and are designed to protect from road dirt and stones.

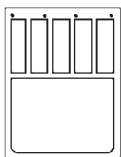

Part No.	Ref. No.	Width	Length	Thickness
1924MF-HD	376700	19"	24"	1/4"
2430MF	376800	24"	30"	1/4"

## Rumber® Stock Trailer Flooring

### *The Smart Alternative for all Your Flooring Needs*

This composite flooring is equivalent to a standard 2" x 8" tongue and groove board (1 1/2" x 7" actual size). Made from 100% recycled tires and plastic which provides a cushioned surface for trailer floors, serving as flooring and rubber mat combined! The pre-scuffed "Traction Board" surface ensures footing. With a 20 year "Wear-Out" warranty\*\* and a lifetime guarantee on workmanship and materials, this durable flooring is made to last! Rumber can be easily cut and drilled using common power tools, and emit no hazardous dust. It is also easy to clean and highly rot resistant.

Part No.	Ref. No.	Description	Actual Dimension	Length
9102-6	386775	2" X 8", COMP	1 1/2" X 7"	6 FT
9102-7	386780	2" X 8", COMP	1 1/2" X 7"	7 FT
9102-16	386785	2" X 8", COMP	1 1/2" X 7"	16 FT
9102-20	386790	2" X 8", COMP	1 1/2" X 7"	20 FT
9102-24	386795	2" X 8", COMP	1 1/2" X 7"	24 FT

\*\* 20 yr. warranty in Livestock/Implement/Utility and 5 yr. warranty in Heavy Equipment

### Rumber™ Installation Guidelines\*

Trailer Type	Max. Supp. Spacing	Screw Size	Max. Screw Spacing	Min. Recommended Support Size
LIVESTOCK	15"	1/4"	30"	2 X 1/4" ANGLE IRON
IMPLEMENT UTILITY	12"	5/16"	18"	2 X 3/8" ANGLE IRON
HEAVY EQUIPMENT	9"	5/16"	18"	3 X 3/8" ANGLE IRON

\* Be certain tongue & groove are tightly meshed before drilling. Two screws minimum per cross member.

*Installation Outside These Guidelines Will Void Warranty*



### Other Styles of Rumber Boards Available

Various lengths of Rumber, smooth sided Rumber (without tongue and groove) or Rumber without the "Traction Board" surface are also available in 2" x 4", 2" x 6" and 2" x 8" dimensions. Call your branch for more details.

## Horse Trailer Pads and Pad Sets

Horse Trailer Pads are used to provide maximum protection and comfort for the horse. The Pads are 9" wide, made with a protective fiber backing, filled with 2" foam and covered with durable black vinyl. Available in 6 or 7 piece sets. Individual Pads available in 4 sizes.

Part No.	Ref. No.	Color	Pieces / Set	Breast Pad	Side Pad	Escape Door Pad
HTP-6PCBK	372800	BLACK	6	TWO 24"	FOUR 60"	
HTP-7PCBK	373200	BLACK	7	TWO 24"	THREE 60" & ONE 40"	ONE 12"
HTP24BK	374000	BLACK	1	ONE 24"	-	-
HTP40BK	374400	BLACK	1	-	ONE 40"	-
HTP60BK	374800	BLACK	1	-	ONE 60"	-
HTP12BK	373600	BLACK	1	-	-	ONE 12"
PS-8	375200	#8 x 3/4" PADDING SCREW WITH FINISHING WASHER				



HARDWARE

## Rumber® Trailer Liner



The Rumber® Trailer Liner is used for Horse, Stock, and Van-Type Cargo Trailers. It is much more durable than plywood, since it is resistant to mildew, mold. Composed of recycled rubber and plastics, it is more flexible and less brittle than 100% poly. See installation tips below.

Part No.	Ref. No.	Thickness	Type	Dimension	Package
9701-200T	376930	.2"	SMOOTH SIDES	48" X 96"	SHEET

### Installation Tips for Rumber® Sheeting

Notice: The Rumber sheeting is a rubber and plastic product, which expands and contracts due to changes in temperature. An 8ft. sheet will shrink or expand approximately 3/16" for every 40 degree Fahrenheit change in temperature. To accommodate the change, fasteners should be placed at a minimum of 2" from the edge of the sheet, and should not be over tightened to allow for movement. The fastener holes should be oversized by at least 1/16" to 1/8". For best results fasten the center of the sheet, and use a 1" strip of metal over the outside edges and support the back every 12 to 16 inches, near the bottom and 16 to 24 inches above the impact area.

## Rubber Bumpers

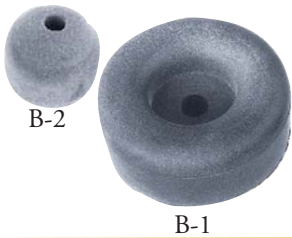

We offer a variety of Bumpers. Small bumpers can be used as door stops, handle cushions or dock bumpers.

Part No.	Ref. No.	Outside Diameter	Height	Recess	Mounting Hole
B-1	385800	2 1/2"	1"	1/2" X 1 1/8"	3/8"
B-2	386000	1"	13/16"	1/4"	1/8"

## Pre-Drilled Rubber Bumpers

Initially designed to mount on the rear of horse trailers to prevent damage to trailer and cargo, the Pre-Drilled Rubber Bumpers have quickly risen in popularity with builders of all types of trailers. We also supply the mounting bars for each bumper size.

Part No.	Ref. No.	Description	Width	A	B	C	D	No. of Holes	Bolt Size
D2-96	386100	ROUND BUMPER	2"	96"	5/8"	2"	11 1/2"	8	3/8"
D3-96	386125	ROUND BUMPER	3"	96"	1 1/4"	4"	11"	8	9/16"
D4-96	386150	ROUND BUMPER	4"	96"	1 1/4"	4"	11"	8	5/8"
SD2-96	386160	SQUARE BUMPER	2"	96"	5/8"	2"	11 1/2"	8	3/8"
SD3-96	386165	SQUARE BUMPER	3"	96"	1 1/8"	4"	11"	8	9/16"
SD4-96	386170	SQUARE BUMPER	4"	96"	1 1/4"	4"	11"	8	5/8"
SB2-96	386175	3/16" x 1" x 96" DRILLED SUPPORT BAR FOR D2-96							
SB34-96	386190	3/16" x 1 1/2" x 96" DRILLED SUPPORT BAR FOR D3-96, D4-96							
2000-96	386195	RUMBER® BUMPER	3"	96"	1 1/4"	4"	11"	8	9/16"



Round Style



Square Style



### What to know when ordering a custom bumper

Square or Round      Size: 2" 3" 4"      Length (A)      Hole Size (B)  
Distance from end of bumper to 1st hole on each end (C)  
Distance between holes (D)      Number of holes

## Cargo Control Products

Packaged in clear clam shell boxes, these products are ideal for retail display. A complete line of product is available, including Tie Down Straps, Ratchet Straps, Tow Straps, and Anchor Points.



Part No.	Ref. No.	Description	Capacity
TA08-110	396401	1" x 10' TIE DOWN STRAP W/CAM BUCKLE	2,000 LB
TA08-106	396402	1" X 6' TIE DOWN STRAP W/CAM BUCKLE	2,000 LB
TA08-115	396405	1" X 15' RATCHET STRAP ASSEMBLY	1,500 LB
TA08-1515	396407	1 1/2" X 15' RATCHET STRAP ASSEMBLY	5,000 LB
TA08-220	396409	2" X 20' RATCHET STRAP ASSEMBLY	4,500 LB
TA08-015	396415	2" X 15' TOW STRAP W/FORGED HOOKS	10,000 LB
TA08-020	396417	2" X 20' TOW STRAP W/ LOOPED ENDS	20,000 LB
TA08-001	404645	CHROME STAKE POCKET ANCHOR, FITS P/U BED STAKE POCKETS	
TA08-380	404650	3/8" BED BOLT ANCHORS	700 LB
TA08-120	404655	1/2" BED BOLT ANCHORS	1,300 LB



## Tie Down Straps

Available in two designs, both with vinyl coated S-hooks. The 1" Tie Down Straps are used in many different ways to secure cargo to pickup trucks, utility trailers, boat trailers, or anywhere a light duty tie down is needed.



Part No.	Ref. No.	Type Fastener	Length	Min. Breaking Strength	Working Load Limit
C51906	396425	CAM BUCKLE	6 FT	1,200 LB	400 LB
75152	396450	RATCHET	15FT	1,200 LB	400 LB



75152

## Cargo Control Equipment

Our Ratchet Cargo Straps give you maximum safety in load control for most flatbed requirements. Assemblies have 2" wide, yellow polyester web straps with a latex treatment for extra protection from moisture and weather. The #802 Replacement Fixed End includes the #801 Ratchet, 2" x 18" wide webbing, with a flat hook on one end.



Part No.	Ref. No.	Description	Breaking Strength	Working Load Limit
802HD-27F	396600	27 FT CARGO STRAP ASSEMBLY WITH 801 RATCHET & FLAT HOOKS	10,000 LB	3,335 LB
802HD-30F	396800	30 FT CARGO STRAP ASSEMBLY WITH 801 RATCHET & FLAT HOOKS	10,000 LB	3,335 LB
801	396805	REPLACEMENT RATCHET FOR 802HD-27F & 802HD -30F	11,000 LB	3,670 LB
802	396810	REPLACEMENT FIXED END FOR 802HD-27F & 802HD -30F	10,000 LB	3,335 LB
802HD-27W	396500	27 FT CARGO STRAP ASSEMBLY WITH 801 RATCHET & WIRE HOOKS	10,000 LB	3,335 LB



801



802HD-27F



802HD-27W

## Strap Winches

The 4" Winches offer flexibility in securing all types of cargo on flatbed trailers, rail cars and other vehicles. Choose from the Fixed Winch designed to be welded in place or the Portable Winch designed to mount various places along the trailers side channel and secured with 2 locking screws. Accommodating up to 4" wide cargo webbing, these Winches lock when tension is applied to the strap for a safe, secure tie-down.



37030



1820



1820P2

Part No.	Ref. No.	Type	Width	Capacity
1820	398180	WELD-ON WINCH	4"	15,000 LB
1820P2	398185	PORTABLE WINCH	4"	15,000 LB
37030	398190	STANDARD WINCH BAR W/KNURLED HANDLE		

## Winch Straps



All our Winch Straps are made of tough polyester web with a latex finish for added protection from moisture and weather conditions. All come with a Flat Hook on one end.



Part No.	Ref. No.	Width	Length	Min. Breaking Strength	Working Load Limit
4821HD-27F	398200	2"	25 FT	10,000 LB	3 335 LB
4821HD-30F	398400	2"	28 FT	10,000 LB	3,335 LB
4821XW-27F	398600	4"	27 FT	15,000 LB	5,000 LB
4821XW-30F	398800	4"	30 FT	15,000 LB	5,000 LB

## Axle Straps



Used for securing a vehicle to the bed of a truck or trailer. The #804AS has a snap hook and ring to form a loop around the axle while the loose end is attached to the ratchet.



804HK

4821HD-AS



802AS

Part No.	Ref. No.	Description	Width	Length	Min. Break Strength
804AS	396820	AXLE STRAP ASSEMBLY	2"	12 FT	5,000 LB
804HK	396900	REP'L RATCHET FOR 804AS	2"	N/A	11,000 LB
4821HD-AS	396830	REP'L AXLE STRAP FOR 804AS	2"	12 FT	12,000 LB
802AS	396815	AXLE STRAP, 2" X 2' W/ D-RINGS			

## Wheel Nets



You can secure a vehicle being towed by wrapping a Wheel Net around the tire and winching it to the trailer. Our Wheel Nets are constructed of tough polyester cargo webbing with a protective latex finish and a flat hook on one end.



Part No.	Ref. No.	Description	Width	Min. Break Strength	Working Load Limit
909	397400	FITS 13" TIRES	2"	7,500 LB	2,500 LB
910	397600	FITS 14" AND 15" TIRES	2"	7,500 LB	2,500 LB
911	397650	FITS 16" AND 16.5" TIRES	2"	7,500 LB	2,500 LB

## Tarp Straps

Constructed of heavy-duty natural rubber with galvanized metal S-hooks. Offers excellent elongation, strength and low temperature flexibility.



Part No.	Ref. No.	Rubber Length	Overall Length
914	398825	9"	15"
1520	398850	15"	20"
2025	398875	20"	25"
3136	398900	31"	36"

## Kinedyne E-Track Cargo Control

Kinedyne E-track is powder coated 12 gauge steel rated at 50,000 psi minimum yield. Track mounts on wall or floor and can be installed with screws, rivets or welding (by qualified installer). Straps are colored: 12' straps are yellow, 16' straps are grey and 20' straps are blue.



Part No.	Ref. No.	Description
ET4310	398100	10' HORIZONTAL STYLE
ET4305	398105	5' HORIZONTAL STYLE
ET2019	398110	10' VERTICAL STYLE
ET6001	398115	D-RING 2.5K 2"W X 6"L
ET1845	398120	WOOD BEAM SOCKET FOR 2" X 6" BOARDS
ET6512	398125	STRAP 2" X 12' 2.5K W/CAMBUCKL
ET6516	398130	STRAP 2" X 16' 2.5K W/CAMBUCKL
ET6520	398135	STRAP 2" X 20' 2.5K W/CAMBUCKL
ET6412	398145	STRAP 2" X 12' 3K W/RATCHET
ET6416	398150	STRAP 2" X 16' 3K W/RATCHET
ET6420	398155	STRAP 2" X 20' 3K W/RATCHET

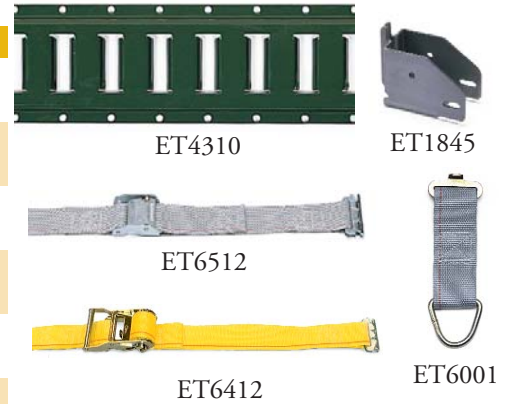

## Packaged U-Bolts

Ideal for boat/pwc/snowmobile trailers, these u-bolts are zinc plated to resist corrosion. Square bend simplifies attachment of hardware to square trailer frames.



Part No.	Ref. No.	D	A	L
381344UB	404700	3/8"	1 3/4"	4"
382144UB	404705	3/8"	2 1/4"	4 1/4"
382385UB	404710	3/8"	2 3/8"	5 1/4"
383384UB	404715	3/8"	3 3/8"	4 1/4"
383385UB	404720	3/8"	3 3/8"	5 1/4"
7162184UB	404730	7/16"	2 1/8"	4"
7163183UB	404735	7/16"	3 1/8"	3"
7163184UB	404740	7/16"	3 1/8"	4"
7164183UB	404745	7/16"	4 1/8"	3"
121785UB	404755	1/2"	1 7/8"	5"
122185UB	404760	1/2"	2 1/8"	5 1/4"

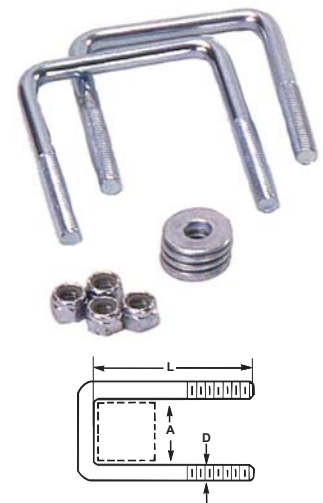

## Bolster and Bunk Brackets

For boat trailers and boat lifts, the 1-piece adjustable bracket mounts the Bolster vertically and the 2-piece adjustable bracket mounts Bunk boards at an angle. The brackets provide additional support and ease in loading and unloading boats. Zinc coating protects against corrosion.

Part No.	Ref. No.	Overall Length	Width	Pieces
106	407000	9 3/8"	2"	1
109	407200	11 3/4"	2"	1
264	407400	8"	2 1/2"	2
294	407600	10"	2 1/2"	2
284	407800	12"	2 1/2"	2
216	407900	REPLACEMENT TOP ANGLE FOR 264, 294, & 284 ASSEMBLIES		
264B	407410	REPLACEMENT BOTTOM BRACKET FOR 264 ASSEMBLY		
294B	407610	REPLACEMENT BOTTOM BRACKET FOR 294 ASSEMBLY		
284B	407810	REPLACEMENT BOTTOM BRACKET FOR 284 ASSEMBLY		



## Roller Brackets



The Universal Roller Brackets will accommodate any size roller length. The One-Piece Bracket is for 12" rollers only. Both Brackets feature a five inch slot which allows vertical adjustment for stabilizing boat on trailer, and zinc coating to protect against corrosion. Both use the 5/8" Roller Shaft (#135) and Pal Nuts (#1310).

Part No.	Ref. No.	Description
400L	408000	UNIVERSAL BRACKET LEFT HAND SIDE
400R	408200	UNIVERSAL BRACKET RIGHT HAND SIDE
1200	408300	ONE-PIECE BRACKET FOR 12" ROLLERS

## Steel Roller Shaft and Pal Nuts



Steel Roller Shaft supports and allows free turning of rollers. Pal Nuts are zinc plated and attach to the ends of the steel shaft to retain the roller within the Universal Roller Brackets (#400L & #400R) and One-Piece Bracket (#1200).

Part No.	Ref. No.	Description
135	408400	STEEL SHAFT 5/8" X 13 1/2"
1310	408600	PAL NUT 5/8" USE WITH 135 SHAFT

## Rubber Side Guide Roller and Cap

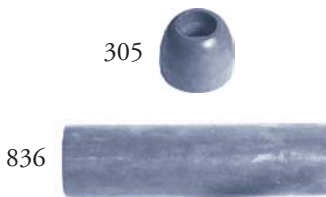

Rubber Side Guide Roller and Cap help center the boat on the trailer, preventing damage to fenders and taillight brackets.

Part No.	Ref. No.	Description	Dimensions	I.D. Hole
305	406600	RUBBER END CAP	2 1/2"	5/8"
836	406800	SIDE GUIDE RUBBER ROLLER	2 1/2" x 9"	5/8"

## Rubber Bow, Deep "V" Keel and Spool-Type Keel Rollers



The Bow Roller acts as a bow stop for a boat and is normally used with a trailers winch stand. Deep "V" Keel Roller is designed to support the added weight of heavier boats by properly fitting the curve of the keel, allowing easier launching and loading of boats. The Spool-Type Keel Roller is designed to support the keel of lighter boats.

Part No.	Ref. No.	Roller	Type	Length	I.D.
803	404800	BOW	"V"	3"	1/2"
804	405000	KEEL	SPOOL	4"	5/8"
805	405200	KEEL	SPOOL	5"	5/8"
812	405400	KEEL	"V"	8"	5/8"
811	405600	KEEL WITH STEEL SLEEVE INSERT	"V"	10"	5/8"
807	405800	KEEL WITH STEEL SLEEVE INSERT	"V"	12"	5/8"

## Rubber Bow Guards

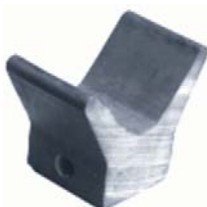

The Rubber Bow Guard acts as a stop to protect and hold the bow of the boat when loading a boat onto a trailer. Attaches to the trailer's winch stand.

Part No.	Ref. No.	Width	Hole I.D.
860	406000	2"	1/2"
862	406400	3"	1/2"





## Brake Actuating Systems

This section consists of various ways to activate and actuate your trailer brakes and is in the following order: Electric Brake Controls, Hydraulic Surge Brake Actuators, Plumbing Line Kits, Breakaway Kits, and Redline Brake Actuating Systems for Vacuum/Hydraulic, Air/Hydraulic or Straight Air Brake Systems.

Brake Controls	L-2-L-4		
Side-Post Mount Battery Adapter Kit	L-4		
Brake Control Accessories	L-4		
Brake Control Installation Kit	L-4		
Breakaway Kits and Accessories	L-5		
Ammeter Gauge	L-5		
Brake Actuators	L-6- L-7		
Hydraulic Line Kits	L-7		
Electric Hydraulic Brake System	L-8		
Vacuum/Hydraulic Trailer Kits	L-10		
Vacuum Pump Kits	L-11		
Air Trailer Kit	L-12 - L14		
Air/Hydraulic Trailer Kits	L-14		
Replacement Pumps	L-15		
Replacement Valves and Repair Kits	L-15		
Replacement Boosters and Reservoirs	L-15		
Hydraulic Fittings	L-16		
Vacuum Couplers, Hose and Hand Cables	L-16		
Low Vacuum Warning Kits	L-16		
Double Flaring Tool	L-17		
Brake Bleeding System	L-17		
Hydraulic Lines and Brackets	L-17		
		<b>How-To Sections</b>	
		Electric Brake Trouble Shooting Guide	L-18
		(Vacuum/Hydraulic Troubleshooting Guide	L-19
		Truck System Test	L-20
		Trailer System Test	L-22

## Redline TA1000 Electronic Brake Control



**Features Include:**

- **Time Actuated Power:** Trailer brakes are gradually applied at pre-set times. Full brake actuation in 2.5 seconds. 100% solid state.
- **Manual Override:** Aides in setting controls and allows manual brake actuation.
- **Two Color LED:** Indicates completed circuit and brake actuation.
- **Installation:** Mounts in any position, no levelling required.
- **Warranty:** Limited 3 year warranty



Part No.	Ref. No.	Description
TA1000	416310	ELECTRONIC BRAKE CONTROL FOR 2-4 BRAKE SYSTEMS

## Redline TA1100 Electronic Brake Control



**Features Include:**

- **Time Actuated Power with "Panic Stop" Override:** Trailer brakes are activated at desired setting of 3 seconds unless "hard" braking of tow vehicle occurs and inertia sensor overrides timer system for panic stop situations.
- **Two Control System:** Controls power output to trailer brakes and braking response.
- **Manual Override:** Aides in setting controls and allows manual brake actuation.
- **LED Display:** Indicates there is a complete electrical circuit.
- **Installation:** Mounts conveniently under vehicle dash.
- **Warranty:** Limited 3 year warranty



Part No.	Ref. No.	Description
TA1100	416300	ELECTRONIC BRAKE CONTROL FOR 2-4 BRAKE SYSTEMS

## Redline TA1200 Digital Brake Control



**Features Include:**

- **Digital Display:** Displays voltage being applied to brakes, presence of short circuit and trailer connection.
- **Time Actuated Power:** Trailer brakes are gradually applied at pre-set times. Full brake actuation in 2.5 seconds. 100% solid state.
- **Manual Override:** Aides in setting controls and allows manual brake actuation.
- **Installation:** Mounts in any position, no levelling required. Digital readout can be reset for installation requiring upside down mounting.



Part No.	Ref. No.	Description
TA1200	416296	DIGITAL BRAKE CONTROL FOR 2-6 BRAKE SYSTEMS

## Tekonsha Voyager Series Brake Controls



**Features Include:**

- **True Proportional Braking Power:** Inertia Activated Sensor.
- **Two Control System:** Controls power output to brakes and braking response.
- **Manual Override:** Aides in setting controls and allows manual application of brakes.
- **LED Light Display:** Indicates a completed electrical circuit, aides in setting controls, changes from green to red indicating relative braking power.
- **Installation:** Mounts conveniently under vehicle dash.
- **Warranty:** Limited five year warranty.



Part No.	Ref. No.	Description
9030	416425	"VOYAGER", ALL ELECTRONIC FOR 2-4 BRAKE SYSTEMS
9035	416625	"VOYAGER XP", ALL ELECTRONIC FOR 6-8 BRAKE SYSTEMS

## Tekonsha Envoy Series Brake Controls



**Features Include:**

- **True Proportional Braking Power:** Inertia Activated Sensor.
- **Two Control System:** Controls power output to brakes and braking response.
- **Manual Override:** Aides in setting controls and allows manual application of brakes.
- **LED Light Display:** Green LED monitors a secure connection with trailer and changes to red to indicate increase of power to the trailer brakes.
- **Installation:** Rounded mounting bracket allows multiple angles of control positioning under dash.
- **Warranty:** Limited five year warranty.



Part No.	Ref. No.	Description
9040	416627	"ENVOY", ALL ELECTRONIC FOR 1-2 AXLES W/BRAKES
9045	416628	"ENVOY SX", ALL ELECTRONIC FOR 1-3 AXLES W/ BRAKES

## Tekonsha Sentinel Brake Control

**Features Include:**

- **True Proportional Braking Power:** Inertia Activated Sensor.
- **Two Control System:** Controls power output to brakes and braking response.
- **Manual Override:** Aides in setting controls and allows manual application of brakes.
- **Five LED Light Display:** Indicates a completed electrical circuit, one light is dedicated to aide in setting control for braking response, the other four change from green to red indicating the relative braking power.
- **Installation:** Mounts flush under vehicle dash.
- **Warranty:** Limited five year warranty.

Part No.	Ref. No.	Description
9055	416630	ALL ELECTRONIC FOR 1-4 AXLES



## Tekonsha Prodigy Brake Control

**Features Include:**

- **True Proportional Braking Power:** Inertia Activated Sensor, no manual leveling.
- **Two Control System:** Controls power output to brakes and braking response.
- **Manual Override:** Aides in setting controls and allows manual application of brakes.
- **Digital Display:** Indicates voltage readout and NC (no connection) if connection is missing. Visual warning if trailer becomes disconnected.
- **Installation:** Control design allows multiple angles of control positioning.
- **Warranty:** Limited lifetime warranty.

Part No.	Ref. No.	Description
90185	416635	ALL ELECTRONIC FOR 1-4 AXLES



## Hayes-Lemmerz Energize Series Brake Controls

**Features Include:**

- **True Proportional Braking Power:** Inertia Activated Sensor.
- **Two Control System:** Controls power output to brakes and braking response.
- **Manual Override:** Aides in setting controls and allows manual application of brakes.
- **LED Light Display:** Indicates there is a completed electrical circuit, and informs operator of vehicle's braking response and relative braking power.
- **Installation:** Mounts conveniently on top or under vehicle dash.
- **Warranty:** Limited five year warranty.

Part No.	Ref. No.	Description
81741B	416225	ENERGIZE III, ELECTRIC BRAKE CONTROL, 1-2 AXLES
81745	416240	ENERGIZE XPC, ELECTRIC BRAKE CONTROL, 1-3 AXLES

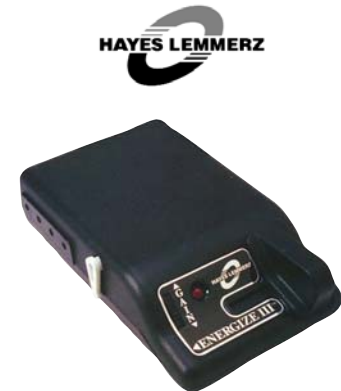

## Hayes-Lemmerz Micro Control HDPlus Brake Control

**Features Include:**

- **True Proportional Braking Power:** Inertia Activated Sensor monitors towing vehicle's deceleration which causes trailer to brake proportionately to the tow vehicle.
- **Two Control System:** Controls power output to brakes and braking response.
- **Push Button Manual Override:** Push button aides in setting the control and allows manual application of trailer brakes.
- **Four LED Light Display:** Indicates there is a completed electrical circuit, and informs operator of vehicle's braking response and relative braking power.
- **Installation:** Mounts conveniently on top or under vehicle dash.

Part No.	Ref. No.	Description
81750	416250	KELSEY MICRO CONTROL H/D, ELECTRONIC FOR 1-4 AXLES



## Warner Hydraulic Utility Brake Control



The Warner Hydraulic/Electric Control 1300-76 has a displacement of less than .02 cubic inch which meets vehicle manufacturers' requirements. It is adjustable for a wide range of vehicle brake system pressures with low pressure sensitivity that assures immediate and smooth engagement of trailer brakes. The special design of the internal multiple resistor pack provides heat sinking and heat dissipation characteristics. Rated for up to 8 brakes, 30 amps.

Part No.	Ref. No.	Description
1300-76	417000	BRAKE CONTROL, WARNER ELECTRIC, FOR 4-8 BRAKES

## Warner Air Utility Brake Control



The Warner Air Utility Control interconnects with air brake systems of tow vehicles and automatically operates electric trailer brakes in sychronization with air brakes. It may be used in FMVSS 121 systems. The manual override feature operates trailer brakes only. The unit displaces only 2.8 cubic inches of air at 100 PSI. It is adjustable for a wide range of vehicle brake system pressures with low pressure sensitivity that assures immediate and smooth engagement of trailer brakes. The special design of the internal multiple resistor pack provides heat sinking and heat dissipation characteristics.

Part No.	Ref. No.	Description
1300-80	417400	AIR OPERATED FOR AIR BRAKE TRUCK TO PULL ELECTRIC TRAILER

## Brake Control Installation Kit



All in one package, everything needed for proper brake control installation! Redline offers a universal kit including all wire and electrical items necessary for a standard brake control installation. Vehicle specific kits plug directly into the vehicle wiring harness.

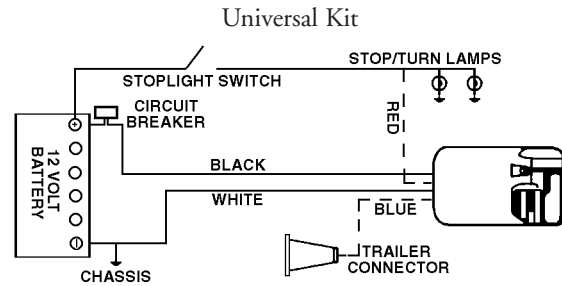

TA05-020



TA05-025

Part No.	Ref. No.	Description
TA05-020	417900	UNIVERSAL BRAKE CONTROL INSTALLATION KIT, INCLUDES WIRE, TERMINALS & BREAKER
TA05-025	417902	BRAKE CONTROL INSTALLATION HARNESS, FOR NEW BODY STYLE GM TRUCKS WITH TOWING PACKAGE
TA05-030	417905	BRAKE CONTROL INSTALLATION HARNESS, FOR 92-CURRENT FORD F SERIES P/U, E SERIES VANS 94-98 EXPLORER & 97-98 EXPLORER W/TOWING PACKAGE
TA05-035	417915	BRAKE CONTROL INSTALLATION HARNESS FOR 96-01 DODGE RAM PICKUPS

## Brake Control Accessories

Part No.	Ref. No.	Description
2180S	421425	PULSE PREVENTER PREVENTS INTERFERENCE BETWEEN 4-WAY FLASHER AND BRAKE CONTROL

## Side-Post Mount Battery Adapter Kit

Allows direct connection to battery on vehicles using a side-post battery.

Part No.	Ref. No.	Description
TA05-040	417910	SIDE POST MOUNT BATTERY ADAPTER KIT, CONTAINS ADAPTERS, NUTS & CONNECTORS (QTY 2)



## Ammeter Gauge

- Diagnostic Tool For All Electrical Work
- Clip-on (No wires to cut), Comes with instructions
- Pinpoints shorts, Broken Wiring or Bad Ground
- Easier and faster than test light

Part No.	Ref. No.	Description
810	421450	CLIP-ON ELECTRIC BRAKE AMMETER GAUGE

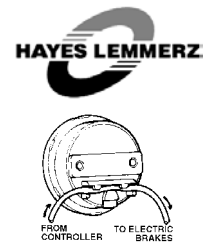

## Breakaway Kits and Accessories

These Electronic Breakaway Kits are the most advanced system available, featuring a rechargeable sealed maintenance-free battery and an optional charger for trouble-free towing. Choice of 3 Battery Box Designs - (See Below)

- Compact Design
- Rechargeable, sealed maintenance-free 12 V Battery
- Dependable
- Wide operating Temperature (-76°F to +140°F)
- Meets or Exceeds D.O.T Regulations



Part No.	Ref. No.	Description	Battery	Switch	Charger	Application
1026	419300	Breakaway Kit, no charger	4 amp/hr	2010	N/A	1 -2 axles
1028A	419312	Breakaway Kit, with charger	4 amp/hr	2010	1024	1-2 axles
2026	419410	Breakaway Kit, no charger	5 amp/hr	2010	N/A	1-3 axles
2028	419420	Breakaway Kit, with charger	5 amp/hr	2010	2024	1-3 axles
BA10-100	419190	Redline Breakaway Kit, no charger ("bulk", sold in case lots of 12 only)	4.5 amp/hr	Nylon	N/A	1-2 axles

### Kits using 2018 Box

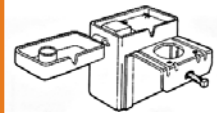

Part No.	Ref. No.	Description	Battery	Switch	Charger	Application
20005	419425	Breakaway Kit, no charger	5 amp/hr	2010	N/A	1-3 axles
20015	419427	Breakaway Kit, with charger	5 amp/hr	2010	2024	1-3 axles
BA10-120	419195	Redline Breakaway Kit, no charger ("bulk", sold in case lots of 10 only)	4.5 amp/hr	Nylon	N/A	1-2 axles

### Kits using 2051 Box



Part No.	Ref. No.	Description	Battery	Switch	Charger	Application
20010	419430	Breakaway Kit, no charger	5 amp/hr	2010	N/A	1-3 axles
20020	419440	Breakaway Kit, with charger	5 amp/hr	2010	2024	1-3 axles

### Kits using 20000 Box



## Accessories

Part No.	Ref. No.	Description
2018	420210	BATTERY CASE, POLYETHYLENE PLASTIC, A-FRAME OR JACK POST MOUNT
20000	420215	BATTERY CASE, POLYETHYLENE PLASTIC, LOCKABLE, FLAT SURFACE MOUNT, WELD-ON
2051	420220	BATTERY CASE, POLYETHYLENE PLASTIC, LOCKABLE, FLAT SURFACE MOUNT, BOLT-ON
BA01-010	419240	SEALED LEAD ACID BATTERY , 12 VOLT, 4.5 AMP/HR FOR 1-2 AXLE TRAILERS
BA01-020	419245	SEALED LEAD ACID BATTERY , 12 VOLT, 5 AMP/HR FOR 1-3 AXLE TRAILERS
2009	419800	BREAKAWAY SWITCH, ALL METAL WITH SILVER CONTACT POINTS & BRASS PULL PIN
1024	420885	MAINTAINENCE BATTERY CHARGER, 12 VOLTS (WILL NOT FULLY RECHARGE BATTERY)
2024	420900	QUICK BATTERY RECHARGER, 12 VOLT (WILL RECHARGE BATTERY IN APPROX 4-5 HR)
2010	420000	BREAKAWAY SWITCH, NYLON CASE, WELDABLE METAL TAB, SILVER CONTACT POINTS, NYLON PULL PIN
2010A	420100	REPLACEMENT NYLON PULL PIN & CABLE FOR 2010 BREAKAWAY SWITCH

## Atwood Brake Actuators



Atwood Actuators have a heavy gauge stamped steel housing with a ball socket assembly. Breakaway mechanism sets and locks the trailer brakes in the event of tow vehicle/trailer separation. The unique pivot linkage permits a lightweight, more compact design. The electrodeposited enamel finish exceeds A.S.T.M. 96-hour salt-spray test requirements providing corrosion protection. The "Reverse Lock-Out" lever allows for easier backing up of trailer.



Part No.	Ref. No.	Description
82541	302000	ACTUATOR, PAINTED WELD-ON, 2" BALL 3" TONGUE, 6,000 LB CAP
84132	302100	ACTUATOR, PLATED BOLT-ON, 2" BALL 3" TONGUE, 6,000 LB CAP
83000	302725	ACTUATOR, PAINTED WELD-ON, 2" BALL 3" TONGUE, 8,000 LB CAP
83010	302750	ACTUATOR, PLATED BOLT-ON, 2" BALL 3" TONGUE, 8,000 LB CAP
84258	304225	REPLACEMENT BOOT KIT FOR 82541
85841	304250	REPLACEMENT MASTER CYLINDER FOR 82541, AFTER 1980
87478	304350	REPLACEMENT MASTER CYLINDER CAP & GASKET FOR 82541, AFTER 1980
85830	304400	REPLACEMENT SHOCK FOR 82541 ACTUATOR, AFTER 1980
85852	304450	REPLACEMENT PUSH ROD KIT FOR 82541

## Demco Brake Actuators



Demco hydraulic brake actuators are specifically designed to perform even in the harshest braking environments. The master cylinder cap has an automotive-style diaphragm for a completely enclosed brake system preventing brake fluid contamination. Master cylinder pushrod is covered by a rubber boot for additional dirt and moisture protection. DA66 & DA9150 actuators utilize heavy-duty self lubricating rollers, DA10 & DA20 use UHMW nylon wear pads, totally eliminating the potential for roller "freeze-up". Common repair parts are interchangeable between models, minimizing the need for large service parts inventory.



DA66

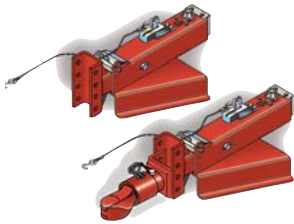

DA9150

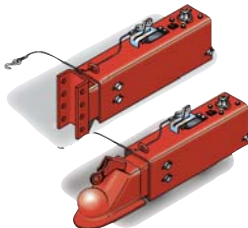

DA10

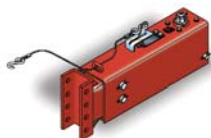

DA20

Part No.	Ref. No.	Description
<b>6K Actuator</b>		
8606701	302190	DA66 6K ACTUATOR, 2" BALL, 3" CHANNEL MOUNTING
<b>7.5K A-Frame Actuator</b>		
8759522	302275	DA9150 ACTUATOR W/CHANNEL ONLY
DA9150-2HBC	302280	DA9150 ACTUATOR W/ADJ 2"H-BLOW COUPLER (7,000 LB.)
DA9150-2516HBC	302285	DA9150 ACTUATOR W/ADJ 2 5/16"H-BLOW COUPLER
<b>10K Actuator</b>		
8103102	302775	DA10 ACTUATOR W/FIXED 2 5/16" COUPLER
8101222	302815	DA10 ACTUATOR W/CHANNEL ONLY
DA10-3ADJEYE	302820	DA10 ACTUATOR W/3" ADJ EYE
DA10-2516ADJ	302845	DA10 ACTUATOR W/ADJ 2 5/16" COUPLER
DA10-2516ADJ-HBC	302846	DA10 ACTUATOR W/ADJ 2 5/16"H-BLOW COUPLER
<b>20K Actuator</b>		
8202022	302875	DA20 ACT W/CHANNEL ONLY
DA20-2516ADJ	302880	DA20 ACTUATOR W/ADJ 2 5/16" COUPLER (12,500 LB. CAP.)
DA20-3ADJEYE	303020	DA20 ACTUATOR W/3" ADJ EYE
<b>Replacement Parts</b>		
BP30-010	304001	MASTER CYLINDER, ALL MODELS
BP31-010	304021	MASTER CYLINDER CAP, ALL MODELS
BP32-010	304041	SHOCK FOR DA66 ACTUATORS
BP32-020	304044	SHOCK FOR DA91, DA10, DA20 ACTUATORS
BP33-010	304061	BREAKAWAY CABLE & LEVER FOR DA91, DA10, DA20
BP33-020	304064	BREAKAWAY CABLE & LEVER FOR DA66 ACTUATORS

## Toledo Brake Actuators

This Toledo Actuator is a rugged design with standard 50 degree A-frame mount flange. It has a breakaway device which sets and locks the trailer brakes in the event of tow vehicle/trailer separation. The unique shock absorber/coil spring design of this Actuator provides smooth positive stopping power eliminating the possibility of damaging peak pressures to the system. 5,000–6,000 G.V.W.R. capacity, depending on coupler used.

Part No.	Ref. No.	Description
16005	302400	ACTUATOR WITH 2" - 2 1/8" FABRICATED FULTON COUPLER -6,000 LB
16006	302600	ACTUATOR WITH 2" HAMMERBLOW COUPLER - 5,000 LB.
16039	302700	ACTUATOR WITH 2 5/16" HAMMERBLOW COUPLER - 6,000 LB.
1745	305205	REPLACEMENT NYLON PIVOT BUSHINGS FOR TOLEDO TA-6 (8 REQUIRED PER ACTUATOR)
1753	305220	1/2"-20 SELF-LOCK PIVOT SHAFT NUT FOR TOLEDO TA-6 (8 REQUIRED PER ACTUATOR)
1760	305240	REPLACEMENT CONNECTOR GASKET "INNER" 1/2" ID FOR TOLEDO TA-6 ACTUATOR
1761	305260	REPLACEMENT CONNECTOR GASKET "OUTER" 19/32" ID FOR TOLEDO TA-6 ACTUATOR
1808-1	305280	REPLACEMENT PIVOT LINK FOR TOLEDO TA-6 (4 REQUIRED PER ACTUATOR)
1829	305300	PIVOT SHAFT FOR TOLEDO TA-6 (4 REQUIRED PER ACTUATOR)
1833	305320	REPLACEMENT MASTER CYLINDER SWIVEL CONNECTOR FOR TOLEDO TA-6 ACTUATOR
1834	305340	REPLACEMENT SWIVEL CONNECTOR BOLT FOR TOLEDO TA-6 ACTUATOR
1844-2	305360	REPLACEMENT SHOCK ABSORBER FOR 16005, 16006 ACTUATORS
6018	305380	REPLACEMENT MASTER CYLINDER CAP
10614	305400	REPLACEMENT MASTER CYLINDER FOR 16005, 16006 ACTUATORS



## Hydraulic Line Kits

Redline Hydraulic Line Kits come complete with all necessary lines, tee fittings, hoses, brackets and clips to properly plumb hydraulic brake axles. Torsion axles require additional line kits, (80910, or 80910-T), or use 9579-2 Deluxe kit with limited access flex hoses included.

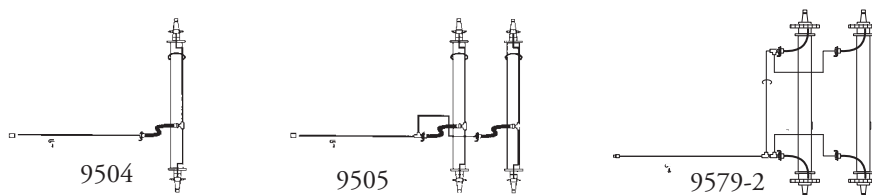

Part No.	Ref. No.	Description
9504	256500	HYD LINE KIT SINGLE AXLE, DRUM
9505	256525	HYD LINE KIT TANDEM AXLE, DRUM
80910	256550	HYD LINE KIT TF AXLE (1WHL) USE W/9504, 9505
80910-T	256575	HYD LINE KIT TF AXLE (1WHL) W/LMTD ACCESS, USE W/ 9504, 9505
9579-2	256580	HYD LINE KIT TANDEM AXLE, DELUXE DRUM
9579-01	256585	HYD LINE KIT, 3RD AXLE, DELUXE DRUM
9578-01	256590	HYD LINE KIT, 3RD AXLE, DELUXE DISC
9501	256595	HYD LINE KIT, 3RD AXLE, FOR VAC&AIR/HYD SYS,DRUM



## Carlisle Hydrastar Electric-Hydraulic Brake Actuator



- 12V DC powered electric-hydraulic pump-style actuator for electronically controlled hydraulic brakes.
- No special controller needed, can be operated by vehicle brake light circuit or standard electric brake controller (for optional performance, use brake controller)
- “Unloading Piston” feature instantly releases hydraulic pressure upon stop of brake signal, eliminates pump-style actuator “brake drag”
- Completely sealed unit, approved for marine/submersible applications.
- Actuator designed for single or tandem axle applications.
- Compact design, measures 3.25”w x 5.75”h x 17.5”l



Part No.	Ref. No.	Description
381-7008	247620	HYDRASTAR 800PSI UNIT ONLY, FOR UP TO 2 AXLES W/12 X 2 DUO-SERVO BRAKES
HYD0800-2A	247622	HYDRASTAR 800PSI DRUM TDM, W/9505 LINE KIT & BREAKAWAY
HYD0800-2	247625	HYDRASTAR 800PSI DRUM TDM, W/DLX LINE KIT & BREAKAWAY
381-7010	247630	HYDRASTAR 1000PSI UNIT ONLY, FOR UP TO 2 AXLES, DEXTER 8K-15K DRUM
HYD1000-2	247635	HYDRASTAR 1000PSI DRUM TDM, W/DLX LINE KIT & BREAKAWAY

## ElecDraulic™ Electric-Hydraulic Brake System



- 12V DC powered electric gear-driven booster system for electronically controlled hydraulic brakes
- Internal microprocessor takes signal from electric brake control and converts to hydraulic pressure for smooth trailer braking
- Superior braking responsiveness, can apply full pressure in 0.3 seconds
- Pre-wired electronics, only 3 wires (positive, ground & brake signal) to connect
- ABS upgradeable with plugin connections (axle must be equipped w/ ABS sensors)
- Brake-bleed button for 1 person testing and bleeding of brake system
- Complete booster system includes built-in breakaway battery, hydraulic line kit, breakaway switch & 7-pole trailer junction box for easy installation.
- ElecDraulic booster measures 10.875”w x 8.875”h x 21.25”l

### ElecDraulic Trailer Brake Systems

Part No.	Ref. No.	Description
99108-000-2	247610	ElecDraulic 800 psi tandem axle system for 12x2 duo-servo brakes
99110-000-2	247612	ElecDraulic 1000 psi tandem axle system for Dexter 8K-15K drum
99116-000-2	247615	ElecDraulic 1600 psi tandem system for 10K-12K disc brake axles

### ElecDraulic Universal Truck Harness & Accessories

Part No.	Ref. No.	Description
98020	247608	Universal Trk Harness w/relay for trucks w/o factory tow package
79019-8	247609	30 amp breaker for GM/Ford w/tow package (not needed for Dodge)
9579-01	256585	Deluxe 3RD axle line kit, drum
9578-01	256590	Deluxe 3RD axle line kit, disc



# **R**edline<sup>SM</sup> Brake Actuating Systems

We now offer the full line of Redline Brake Actuating Systems. Realizing the need for brake systems to be truly compatible with each of the many brake manufacturers, Redline has developed a system for each manufacturer of hydraulic brakes with a strong emphasis on the requirement of fluid displacement and line pressure.

Redline Brake Actuating Systems can offer you:

- Vacuum Pumps and Mounting Kits
- Vacuum/Hydraulic Trailer Kits
- Straight Air Trailer Kits
- Vacuum/Hydraulic Truck Kits
- Air/Hydraulic Trailer Kits
- Technical Support for Trouble-Shooting
- Technical Support to Design a "Custom" System for You!

## **Vacuum/Hydraulic Brake Systems**

Vacuum/hydraulic braking systems are available for trailer axles in the 6K to 15K range of capacity. For axles in this range, the vacuum/hydraulic brake system provides superior performance to electric brake systems and are more economical than air brake systems.

Vacuum/hydraulic brake systems consist of a vacuum pump (in most cases), a truck synchronizing valve and a trailer vacuum/hydraulic booster system. The vacuum pump is required to maintain a constant vacuum level of 15 in.Hg. or greater necessary for adequate trailer braking power. The degree of trailer braking power is matched to the deceleration of the truck by the truck synchronizing valve. This is accomplished in conjunction with the operation of the trailer vacuum/hydraulic booster. The trailer booster is a device which increases the amount of hydraulic brake fluid pressure available for trailer braking by using vacuum as a source of added mechanical energy. The vacuum/hydraulic booster is capable of producing hydraulic brake fluid pressures for braking in the range of 750 PSI to a maximum of 2,000 PSI. The size of the booster determines the final hydraulic pressure. The trailer system is carefully selected for use on specific axle types to ensure that the proper hydraulic pressure is available for the brake system.

## **Air/Hydraulic Brake Systems**

Air/hydraulic brake systems are available for trailer axles in the 6K to 15K range of capacity. For axles in this range, the air/hydraulic brake system provides superior performance to electric brake systems and are more economical than air brake systems.

Air/hydraulic brake systems use an air/hydraulic booster as the power braking device. The truck air pump or compressor is required to maintain a constant air level of 100 PSI or greater necessary for adequate trailer braking power. The degree of trailer braking is matched to the deceleration of the truck by the truck synchronizing valve. This is accomplished in conjunction with the operation of the trailer air/hydraulic booster. The trailer booster is a device which increases the amount of hydraulic brake fluid pressure available for trailer braking by using compressed air as a source of added mechanical energy. The air/hydraulic booster is capable of producing hydraulic brake fluid pressures for braking in the range of 750 PSI to a maximum of 1,500 PSI. The size of the booster determines the final hydraulic pressure. The trailer system is carefully selected for use on specific axle types to ensure that the proper hydraulic pressure is available for the brake system.

## 9100 Series Vacuum/Hydraulic Truck Control Kits



The 9100 Series Vacuum/Hydraulic Kits are designed to provide hydraulic brake actuation/control for trailers. All Kits include a low vacuum warning light and gauge panel to conform to applicable requirements of the Department of Transportation and are compatible with Anti-lock Brake

Systems. These Kits will allow hydraulic braked trucks with adequate vacuum supply to be equipped to pull trailers equipped with Vacuum/Hydraulic brakes. Trucks with inadequate vacuum supply must also be equipped with the appropriate 9600 Series Vacuum Pump Kit. The unique design features of the Truck Control Valve extend the life and dependability of the complete truck control system and include several new features such as the following:

- Low vacuum sensor
- Hydraulic connection and piston built into one unit outside of the valve to prevent the possibility of brake fluid entering the truck valve or vacuum pump
- Complete, detailed instructions are provided with every kit.
- Low vacuum warning panel is included in the kit.
- Different color quick couplings to differentiate between the manifold and control lines

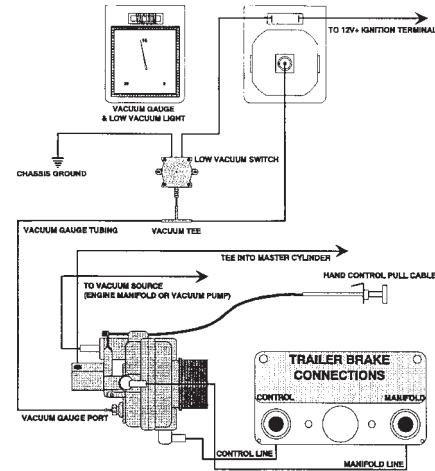
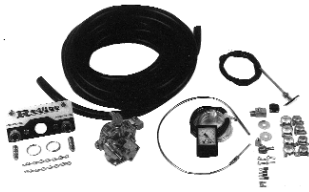

Part No.	Ref. No.	Application
9107	247750	3/4-1 TON TRUCKS (ALL) AND 1 1/2 TON AFTER 1987
9111	247775	1 1/2 TON TRUCKS BEFORE 1987

## 9200 Series Vacuum/Hydraulic Trailer Kits



The 9200 Series Vacuum/Hydraulic Trailer Kits are designed to provide brake actuation for trailers towed by trucks equipped with vacuum/hydraulic brake control systems. The 9200 Series Kits are available for all axle capacities. Every axle manufacturer has set different standards requiring various amounts of hydraulic line pressure and fluid displacement. We offer trailer kits that fit the appropriate axle and manufacturer being used. All trailer kits come with enough hydraulic lines and fittings to plumb 2

axles. For triple axle applications, order #9501 Third axle line and fittings kit.

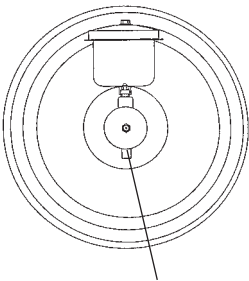

### BOOSTER SIZE IDENTIFICATION

- (8 = 7208 BOOSTER 800 PSIG.)
- (0 = 7210 BOOSTER 1000 PSIG.)
- (2 = 7212 BOOSTER 1200 PSIG.)
- (6 = 7216 BOOSTER 1600 PSIG.)

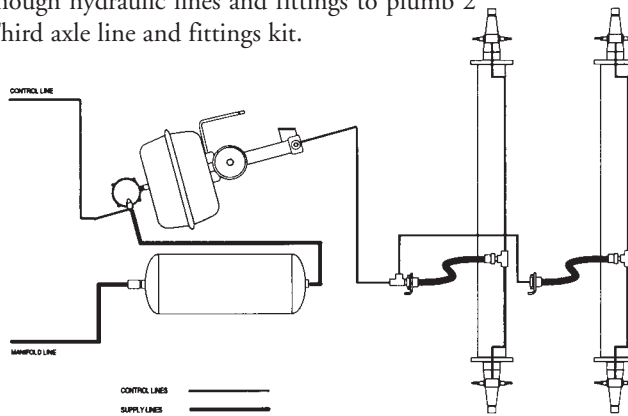

Part No.	Ref. No.	Application
9208-2KT	248815	12" x 2" DUO-SERVO BRAKES (5,200 LB - 7000 LB AXLES)
9210-2KT	248825	DEXTER 8K - 15K DRUM BRAKES
9212-2KT	248835	HAYES/ALKO 8K DRUM
9215-2KT	248845	HAYES/ALKO ALL 9K THRU 12K DRUM
9216-2KT	248855	10K AND 12K DISC (ALL MANUFACTURERS)

## 9600 Series Vacuum Pump Kits

Pump Kits are required for engines which produce insufficient vacuum for trailer brake operation. The 9600 Series Vacuum Pump Kits provide adequate vacuum supply for vehicles to actuate vacuum/hydraulic brakes. These Kits are used with the 9100 Series Truck Kits to make a complete vacuum/hydraulic brake system.

**Redline**  
Brake Actuating Systems

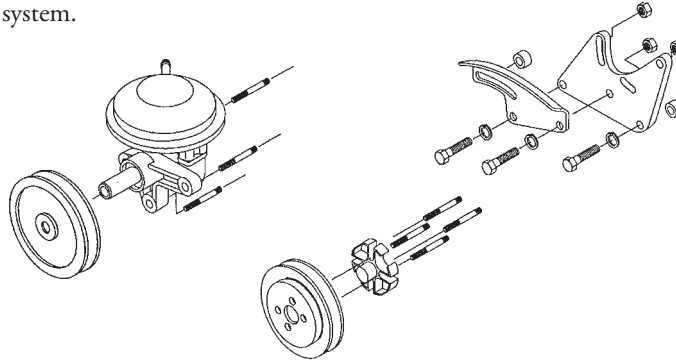

Part No.	Ref. No.	Truck Type / Engine Size	Year Model	Replacement Pump No.
9616	248100	CHEV/GMC 6.0 L V-8 EFI GAS	2000-01	7611
9622 *	248500	CHEV/GMC 1/2-1 TON 454 FI	1988-93	7611
9623	248525	CHEVY 454 ENG W/SERPENTINE BELT	1994-96	7616
9624	348530	CHEV/GMC 454 VORTEC INJECTION (W/AC)	1996-00	7616
9625	248540	CHEVY 8.1L EFI GAS	2001	7616
9630	248650	FORD 1/2-1 TON 460 FI	1988-98	7611
9642	248660	FORD 1/2-1 TON 6.9/7.3 L DIESEL	1983-92	7610
9643 **	248661	FORD 1/2-1 TON 7.3 DIESEL	1992-93	7613
9644	248663	FORD 7.3 TURBO DIESEL W/DIRECT INJECTION	1994	7616
9645	348664	FORD 7.3L DIESEL W/ DIRECT INJECTION	1995-98	7617
9646	248665	FORD 350 SUPER DUTY W/7.3L DIESEL "POWER STROKE"	1999-01	7617
9652	248666	FORD 6.6/7.8 DIESEL	1987-92	7611
9653	248667	FORD FD1060 DIESEL, HYD BRAKE	1993-99	7611
9660	248669	INTERNATIONAL DT360/DT466 DIESEL	1980-86	7611
9661	248672	INTERNATIONAL DT360/DT466 DIESEL	1987-93	7611
9670	248675	DODGE 5.9 CUMMINS DIESEL	1989-91	7611
9671	248685	DODGE 5.9 CUMMINS DIESEL W/TURBO INTERCOOLER	1991-93	7611
9672	248690	DODGE 5.9 CUMMINS DIESEL W/TURBO INTERCOOLER	1994-98	7611
9673	248691	DODGE 24 VALVE DIESEL	1998-01	7611
9675	248695	DODGE V-10	1994-98	7616
9685	248750	CHEV/GMC 3116 CAT DIESEL	1990-98	7611
9686	248755	CHEV/GMC 3126 CAT DIESEL	1998-99	7611
9690 **	248775	CHEV/GMC 1/2-1 TON 6.2/6.5 TURBO DIESEL	1992-93	7616
9691	248780	CHEV/GMC 6.6L DURAMAX DIESEL	2001	7616

\* For trucks with alternator on driver's side.

\*\* For trucks with serpentine belt drive only. Will not fit trucks using V-Belt Drive



### 8102 Air Trailer Kit



The 8102 Air Trailer kit is designed for tandem axle trailers with out spring brakes that do not comply with revised FMVSS571.121 brake system mandates effective March 1, 1998 & should only be used on vehicles that are exempt from those compliance requirements.

Kit includes mounting hardware, fittings, glad hands, one 1488 cu.in. tank, tank drains and all required valves. Air brake tubing is not included due to variations in lengths required in individual installations.

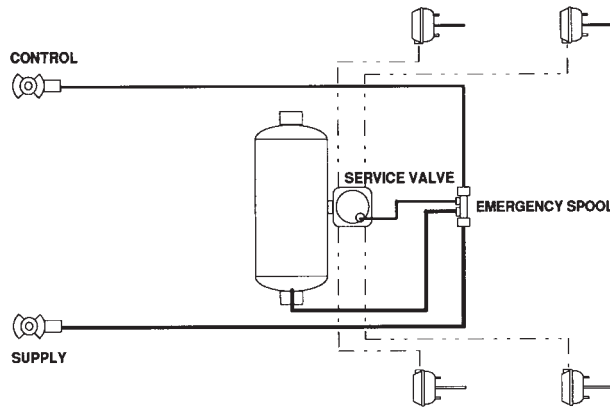

Part No.	Ref. No.	Description
8102	249800	AIR TRAILER KIT FOR 2 AXLES W/O SPRING BRAKES, DESIGNED FOR TRAILERS EXEMPT FROM FMVSS571.121
6606-1	249900	3/8" AIR BRAKE TUBING, 100' ROLL

### 8202-1 Air Trailer Kit



The 8202-1 Air Trailer kit is designed for tandem axle trailers with spring brakes that do not comply with revised FMVSS571.121 brake system mandates effective March 1, 1998 & should only be used on vehicles that are exempt from those compliance requirements.

This Kit will support spring brakes of type 16-24, type 24-30 and type 30-30. The kit includes mounting hardware, fittings, glad hands, one 2800 cu. in. tank, tank drain and all required valves. Air brake tubing is not included due to variations in lengths required in individual installations.

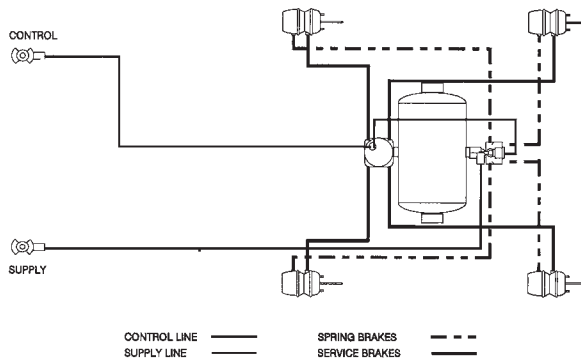

Part No.	Ref. No.	Description
8202-1KT	249851	STRAIGHT AIR TRAILER KIT FOR 2 AXLES WITH SPRING BRAKES, DESIGNED FOR TRAILERS EXEMPT FROM FMVSS571.121
6606-1	249900	3/8" AIR BRAKE TUBING, 100' ROLL

## 8200 Series ABS Air Trailer Kits

The 8200 Series ABS kits are designed for tandem axle trailers that are ABS equipped and have spring brakes. These kits have been designed to conform to all FMVSS571.121 requirements for brake systems, including antilock brake systems, mandated for air brake trailers manufactured after March 1, 1998 and March 1, 2001

These kits will support spring brakes of type 16-24, type 24-30 and type 30-30. Kits include ABS modulator valve(s), ABS warning light, power cord, cable leads, spring brake valve, mounting hardware, fittings, gladhands, and a 2800 cu.in. tank. Air brake tubing is not included due to variations in lengths required in individual installations.

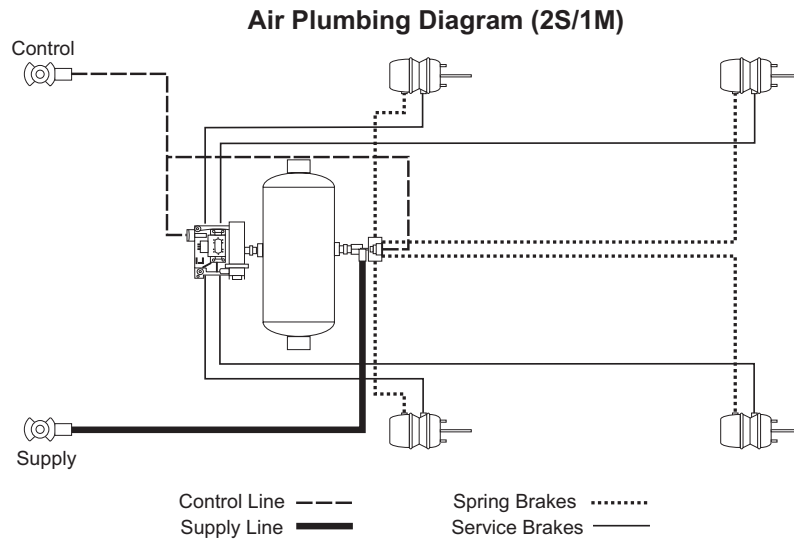

## ABS Wiring Diagram (2S/1M)

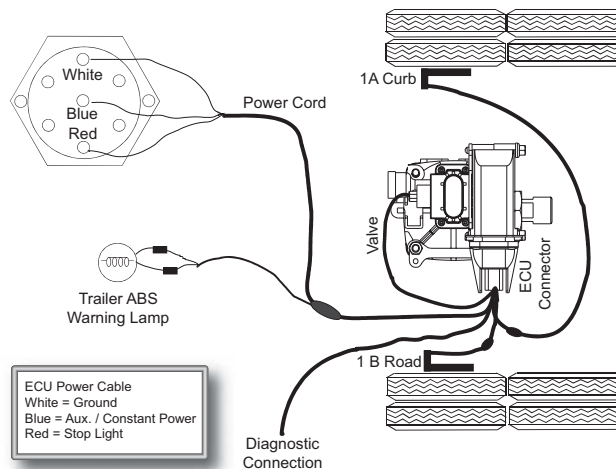

Part No.	Ref. No.	Description
8202-21-1KT	249861	"2S/1M" ABS AIR TRAILER KIT FOR 2 AXLES WITH SPRING BRAKES, (ONE AXLE ABS EQUIPPED)
8202-42-1KT	249866	"4S/2M" ABS AIR TRAILER KIT FOR 2 AXLES WITH SPRING BRAKES, (BOTH AXLES ABS EQUIPPED)
6606-1	249900	3/8" AIR TUBING, 100' ROLL

## 8500 Series Air/Hydraulic Trailer Kits



The 8500 Series Air/Hydraulic Trailer Kits are designed to provide hydraulic brake actuation for trailers pulled by trucks/tractors equipped with air brakes or an air supply system, designed for use on axles with hydraulic brakes suitable for power brake actuation. All Kits include control valves, air tank, air/hydraulic booster and a complete hydraulic line kit for tandem axle trailer. ABS kits also include the necessary components for compliance with FMVSS571.121 requirements for Antilock Brake Systems, mandated for trailers manufactured after March 1, 1998. These ABS kits are "2S/1M" systems, requiring 1 axle to be ABS equipped with sensors and tone rings. The axle is the determining factor for what kit should be used.

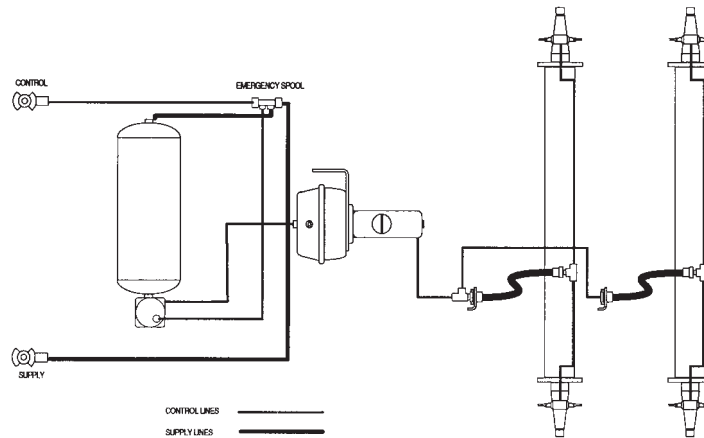

NOTE: An Air Brake Truck pulling an Air-Hydraulic Brake Trailer is not a balanced brake system! Excessive trailer brake wear may occur. Use of 8500 Series Air-Hydraulic System should be used only as last option to operate trailer brakes.

ABS Kits			Non-ABS Kits*	
Part No.	Ref. No.	Application	Part No.	Ref. No.
N/A	N/A	12" x 2" DUO-SERVE DRUM DEXTER/HAYES	8508-2	249500
8510-21-2	249515	DEXTER 8K-12K DRUM	8510-2	249510
8514-21-2	249525	DEXTER 15K DRUM	8514-2	249520
N/A	N/A	HAYES 8K DRUM	8512-2	249600
N/A	N/A	HAYES / ALKO ALL 9K THRU 12K DRUM	8515-2	249610
8516-21-2	249625	10K AND 12K DISC BRAKES (ALL MANUFACTURERS)	8516-2	249620
61340	249630	39 ft. ABS SENSOR EXT. KIT, TO PUT BOOSTER AT TRL FRONT		

\* Non-ABS air/hydraulic kits do not comply with revised FMVSS571.121 brake system mandates effective March 1, 1998 and should only be used on vehicles that are exempt from those compliance requirements.

## Replacement Boosters and Reservoirs

Part No.	Ref. No.	Description	Replacement for:
6485	250600	TANK, 1060 CU IN FOR VACUUM OR AIR	8500/9200 SERIES (ALL)
7208	256210	BOOSTER W/O RELAY VALVE	9208
7208-1	256220	BOOSTER W/ RELAY VALVE	9208
7210	256230	BOOSTER W/O RELAY VALVE	9210
7210-1	256240	BOOSTER W/ RELAY VALVE	9210
7212	256250	BOOSTER W/O RELAY VALVE	9212
7212-1	256260	BOOSTER W/ RELAY VALVE	9212
7216	256270	BOOSTER W/O RELAY VALVE	9215, 9216
7216-1	256280	BOOSTER W/ RELAY VALVE	9215, 9216
6508	256290	AIR/HYDRAULIC BOOSTER	8508
6510	256300	AIR/HYDRAULIC BOOSTER	8510
6512	256310	AIR/HYDRAULIC BOOSTER	8510
6514	256320	AIR/HYDRAULIC BOOSTER	8514
6515	256330	AIR/HYDRAULIC BOOSTER	8515, 8516
9510	257775	FLUID RESERVOIR ASSEMBLY FOR VAC/HYD BOOSTERS	9200 SERIES (ALL)



## Replacement Valves and Repair Kits

Part No.	Ref. No.	Description	Replacement for:
7107	254300	TRUCK CONTROL VALVE, FITS 3/4-1 TON AND 1 1/2 TON AFTER 1987	9107
7111	254325	TRUCK CONTROL VALVE, FITS 1 1/2 TON AND LARGER BEFORE 1987	9111
7300	254700	TRAILER RELAY VALVE	9200 SERIES (ALL)
7564	254800	OPEN CHECK VALVE, 1/2" MALE PIPE x 1/2" HOSE BARB	9200 SERIES (ALL)
7100-50	252500	REPLACEMENT FILTER KIT FOR REDLINE VACUUM VALVES W/FILTER, CAP & SCREEN	9100 & 9200 SERIES (ALL)
7100-60	252650	REPLACEMENT REMOTE LOW VACUUM SWITCH FOR 7107, 7111 VALVES AFTER 1993	9100 SERIES
7107-1	252700	REPLACEMENT HYD MODULE FOR 7107 VALVE (RED)	9107
7111-1	252800	REPLACEMENT HYD MODULE FOR 7111 VALVE (BLUE)	9111
7107-2	252900	REPLACEMENT DIAPHRAM ASSEMBLY FOR 7107, 7111 VALVES	9100 SERIES (ALL)
6102	256335	AIR SERV-RELAY VALVE	8500 SERIES



## Replacement Pumps

When ordering a Replacement Pump, please compare to the photo to the left to determine if yours is a 3 bolt mount or 2 bolt mount, or see pg L-11 for replacement by vehicle application.

Part No.	Ref. No.	Description
7610	253850	VACUUM PUMP AND V-BELT PULLEY , TWO BOLT MOUNT
7611	253865	VACUUM PUMP AND V-BELT PULLEY , THREE BOLT MOUNT
7613	253875	VACUUM PUMP AND PULLEY, THREE BOLT MOUNT FOR SERPENTINE BELT FOR KIT 9643
7616	253900	VACUUM PUMP AND PULLEY, THREE BOLT MOUNT FOR SERPENTINE BELT FOR KIT 9690 & 9614
7617	253950	VACUUM PUMP AND PULLEY, THREE BOLT MOUNT FOR 1 1/8" WIDE SERPENTINE BELT FOR KIT 9645



## Low Vacuum Warning Kits



Part No.	Ref. No.	Description
9522	250550	VACUUM WARNING KIT CONTAINS LIGHT, GAUGE, VACUUM SWITCH AND MOUNTING PANEL

## Vacuum Couplers, Hose and Hand Cables



Part No.	Ref. No.	Description
7550-1	250800	FEMALE COUPLER, 1/2" I.D. VACUUM HOSE, BRASS COLOR (MANIFOLD LINE), USE WITH 7551-1
7550-2	250820	FEMALE COUPLER, 1/2" I.D. VACUUM HOSE, SILVER COLOR (CONTROL LINE), USE WITH 7551-2
7551-1DC	251205	MALE COUPLER FOR 1/2" I.D. VACUUM HOSE, BRASS COLOR (MANIFOLD LINE), USE WITH 7550-1, INCLUDES DUST COVER
7551-2DC	251215	MALE COUPLER FOR 1/2" I.D. VACUUM HOSE, SILVER COLOR (CONTROL LINE), USE WITH 7550-2, INCLUDES DUST COVER
7551DC	251220	DUST CAP KIT FOR REDLINE MALE CONNECTORS W/2 EA CAP, CHAIN & CLAMP
7555	251700	1/2" MALE DUMMY COUPLER PLUG WITH PULL RING (PACKAGE OF 2)
9558-1	251800	VACUUM OVER HYDRAULIC COUPLER CONTROL PANEL FOR TRUCK
7572	252010	1/2" I.D. VACUUM HOSE "VH" RATED PREMIUM 4 BRAIDWALL CONSTRUCTION, WON'T COLLAPSE
7525	252400	REPLACEMENT HAND BRAKE CABLE, 5 FT LONG

## Hydraulic Fittings



301-3



306-3



307-3



3087900



3057818



3087812

Part No.	Ref. No.	Description
301-3	257800	STEEL LINE NUT FOR 3/16" HYDRAULIC STEEL LINE (PKG OF 8)
306-3	258000	LINE UNION FOR 3/16" STEEL LINE (PKG OF 4)
307-3	258200	LINE TEE FOR 3/16" STEEL BRAKE LINE (PKG OF 2)
301-4	258600	STEEL LINE NUT FOR 1/4" HYDRAULIC STEEL LINE (PKG OF 8)
3057818	259200	3/16" FEMALE x 1/4" MALE ADAPTER FOR HYDRAULIC BRAKE LINES (PKG OF 4)
3057828	259400	1/4" FEMALE x 3/16" MALE ADAPTER FOR HYDRAULIC BRAKE LINES (PKG OF 4)
3087812	262600	AXLE LINE TEE FITTING, 3/16" LINE WITH BRACKET (PKG OF 2)
3087900	262625	3/16" HYD SERVICE TEE (PKG OF 2)



## Hydraulic Lines and Brackets

Part No.	Ref. No.	Description
322351	260200	HYDRAULIC STEEL LINE, 3/16" x 51"
323310	260400	HYDRAULIC STEEL LINE, 3/16" x 100' COIL
323410	261600	HYDRAULIC STEEL LINE, 1/4" x 100' COIL
310798	261800	HYDRAULIC FLEX BRAKE HOSE, 7/16"-24 FEMALE x 7/16"-20 MALE, 20.5" LONG
310797	261805	HYDRAULIC FLEX BRAKE HOSE, 3/8"-24 FEMALE x 3/8"-24 MALE, 20.5" LONG
309801	262000	STEEL HOSE BRACKET FOR 310798 HOSE (PKG OF 4)
309802	262200	CLIP FOR 309801 BRACKET (PKG OF 4)
16196	303700	REPLACEMENT FLEX HOSE, FITS 3/16" LINE FITTINGS, 18.5" LONG (3/8"-24 M/F)

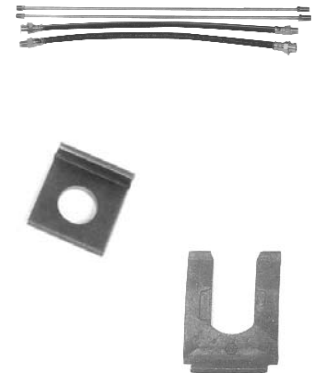

## Brake Bleeding System

This Pressure Bleeding Kit will allow one man to bleed all the air from the hydraulic brake line system unassisted.

Part No.	Ref. No.	Description
T3401	496200	ONE MAN PRESSURE BLEEDING KIT



## Double Flaring Tool

Hydraulic Brake Tubing line ends should be double-flared to prevent "splitting" of the steel line, causing a leak and brake failure. A double flare tool kit properly flares the hydraulic brake tubing supplied in trailer brake kits and hydraulic line kits. Flaring Tool comes in its own case, and is made in the USA. Replacement double-flare adapters are also available. See diagram for proper double flare.



Part No.	Ref. No.	Description
FL2DF2	496300	DOUBLE FLARE TOOL KIT FOR 3/16" THRU 1/2" TUBING
FL2-316	496325	REPLACEMENT 3/16" TUBE ADAPTER (PKG OF 2 EA)
FL2-250	496350	REPLACEMENT 1/4" TUBE ADAPTER (PKG OF 2 EA)

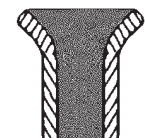
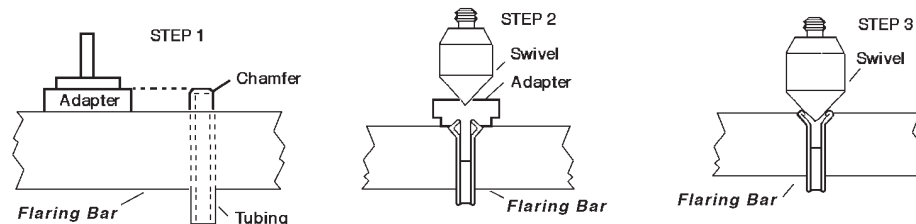

Single Flare

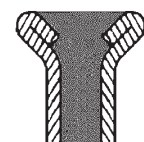

Double Flare

## Electric Brake Trouble Shooting Guide

PROBLEM	CAUSES	REMEDIES
NO BRAKES	OPEN CIRCUITS	FIND AND CORRECT
	SEVERE UNDER ADJUSTMENT	ADJUST BRAKES
	FAULTY CONTROLLER	TEST AND CORRECT
	SHORT CIRCUITS	FIND AND CORRECT
WEAK BRAKES	GREASE/OIL ON MAGNETS/LININGS	CLEAN OR REPLACE
	CORRODED CONNECTIONS	CLEAN/CORRECT CAUSE
	WORN LININGS OR MAGNETS	REPLACE
	SCORED/GROOVED BRAKE DRUMS	MACHINE OR REPLACE
	IMPROPER SYNCHRONIZATION	CORRECT
	UNDER ADJUSTMENT	ADJUST BRAKES
	BLAZED LININGS	REBURNISH OR REPLACE
	OVERLOADED TRAILER	CORRECT
LOCKING BRAKES	UNDER ADJUSTMENT	ADJUST
	IMPROPER SYNCHRONIZATION	CORRECT
	FAULTY CONTROLLER	TEST AND CORRECT
	LOOSE, BROKEN BRAKE PARTS	REPLACE COMPONENTS
	OUT OF ROUND BRAKE DRUMS	MACHINE OR REPLACE
	INSUFFICIENT WHEEL LOAD	ADJUST SYSTEM RESISTOR
INTERMITTENT BRAKES	FAULTY CONTROLLER	TEST AND CORRECT
	BROKEN WIRES	REPAIR OR REPLACE
	LOOSE CONNECTIONS	FIND AND REPAIR
BRAKES PULL TO ONE SIDE	INCORRECT ADJUSTMENT	ADJUST
	GREASE/OIL ON LININGS/MAGNET	CLEAN OR REPLACE
	BROKEN WIRES	FIND AND REPAIR
	BAD CONNECTIONS	FIND AND REPAIR
HARSH BRAKES	UNDER ADJUSTMENT	ADJUST
	IMPROPER SYNCHRONIZATION	CORRECT
	IMPROPER CONTROLLER	CHANGE
	FAULTY CONTROLLER	TEST AND CORRECT
NOISY BRAKES	UNDER ADJUSTMENT	ADJUST BRAKES
	LACK OF LUBRICATION	LUBRICATE
	BROKEN BRAKE PARTS	REPLACE COMPONENT
	INCORRECT BRAKE PARTS	REPLACE
SURGING BRAKES	GREASE/OIL ON LININGS/MAGNET	CLEAN OR REPLACE
	OUT OF ROUND BRAKE DRUMS	MACHINE OR REPLACE
	FAULTY CONTROLLER	TEST AND CORRECT
DRAGGING BRAKES	OVER ADJUSTMENT	READJUST
	OUT OF ROUND BRAKE DRUMS	MACHINE OR REPLACE
	INCORRECT BRAKE PARTS	REPLACE
	BROKEN BRAKE PARTS	REPLACE
	FAULTY BREAKAWAY SWITCH	REPAIR OR REPLACE
	LOOSE WHEEL BEARING ADJ.	ADJUST
BENT SPINDLE	REPLACE AXLE	

## Trouble Shooting Guide

### VACUUM/HYDRAULIC TROUBLESHOOTING GUIDE

**SCOPE AND PURPOSE:**

The purpose of this trouble shooting guide is to provide a concise and orderly procedure for diagnosis of Vacuum/Hydraulic brake systems for trailers. The scope of the diagnostic procedures leads to identification of a failed or troublesome component and recommends a maintenance or replacement of the component. The benefit of this procedure is exact identification of the problem within a minimum of diagnostic time.

**GENERAL PROCEDURE FOR ALL SYMPTOMS:**

The procedure for diagnosis in every case is to run the Truck Test followed by the Trailer Test. The total time for both tests is 7 minutes. If either the Truck Test or Trailer Test leads to other charts, the time will be longer.

It is impossible to correctly diagnose a trailer without the truck which towed the trailer during the time that the problem occurred!

## *INDEX*

Truck Test .....L- 20  
 Trailer Test.....L- 22  
 Low Vacuum Chart .....L- 24

## Truck System Test

This test must be run with the trailer disconnected from the truck and the coupler plugs installed in the vacuum couplers. The truck must be equipped with a vacuum gauge connected to the trailer brake system.

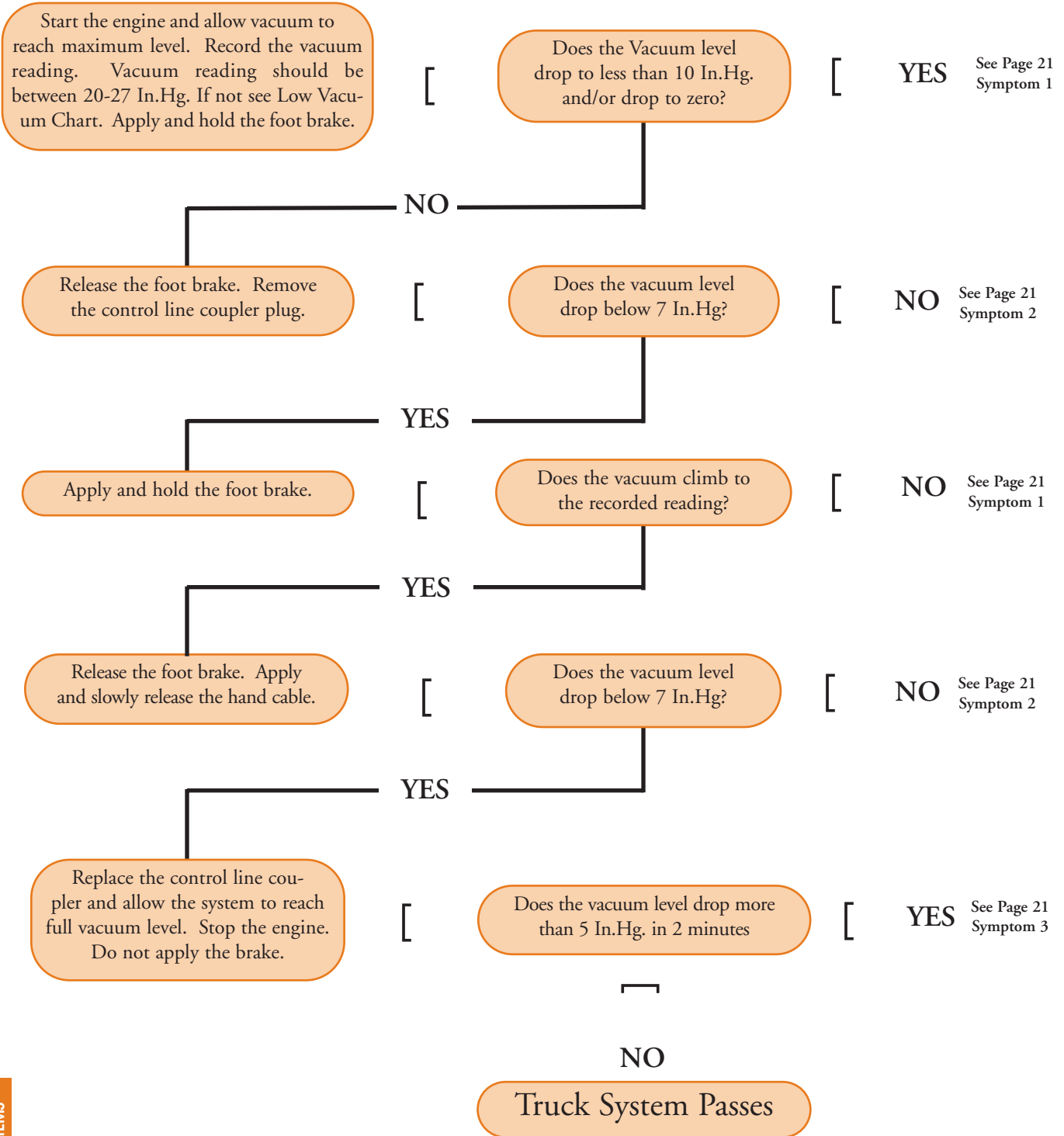

## Symptom 1:

The truck control valve is leaking vacuum when operated.

- 1) If the valve is new, the most probable cause is trash between the piston seal and poppet disc. Clean the trash out of the valve and run the failed portion of the test again.
- 2) If the valve is not new, the most probable cause is a bad piston seal. Replace the diaphragm assembly.

## Symptom 2:

The truck control valve is in a constantly applied condition.

- 1) If the valve is new, the most probable cause is an improper cable installation. Make sure the cable sheath has been cut to the proper length per installation instructions. Make sure the cable sheath is not bound by cable ties in such a manner as to impair freedom of the cable within the cable sheath. Make sure the cable stop is at least 1/8" away from the valve lever when the cable is in the non-applied condition. If the installation passes the above conditions, *see step 2 below*.
- 2) The problem is in the lever assembly or in the valve casting. Replace the valve.

## Symptom 3:

The truck control valve or the vacuum lines are leaking excessively.

- 1) If the valve is new, the most probable cause is trash in the check valve or trash in the poppet. Clean the check valve and/or the poppet and rerun the leakdown portion of the test.
- 2) If the check valve and poppet area are clean, check for leaks at each fitting and hose connection from the valve to the coupler plate. Also check for a leak in the vacuum gauge line. After finding the leak, rerun the leakdown test. *See "Vacuum Leaks"* below for recommended procedures to locate and isolate vacuum leaks.

## Vacuum Leaks:

The recommended procedure to locate a vacuum leak is to isolate each component in the system. For a truck/trailer system, start at the truck control valve by disconnecting the manifold and control line at the valve. Plug the elbows and rerun the leakdown. If the valve passes, reconnect the one line at a time and rerun the leakdown to determine which line leaks. Remember, all vacuum connections are suspect. This includes damaged coupler plugs, damaged female coupler O-rings, gauge hoses, gauge tees; etc. Follow the procedure of adding one connection or length of hose to the system at a time and rerunning leakdown to isolate the problem. This is a tedious and often time consuming procedure, but it yields definite results. Major components in the brake system should have already been eliminated by following the truck test and trailer test.

## TRAILER SYSTEM TEST

This test must be run after the truck system test. Do not attempt to diagnose the trailer system without running the truck system test first.

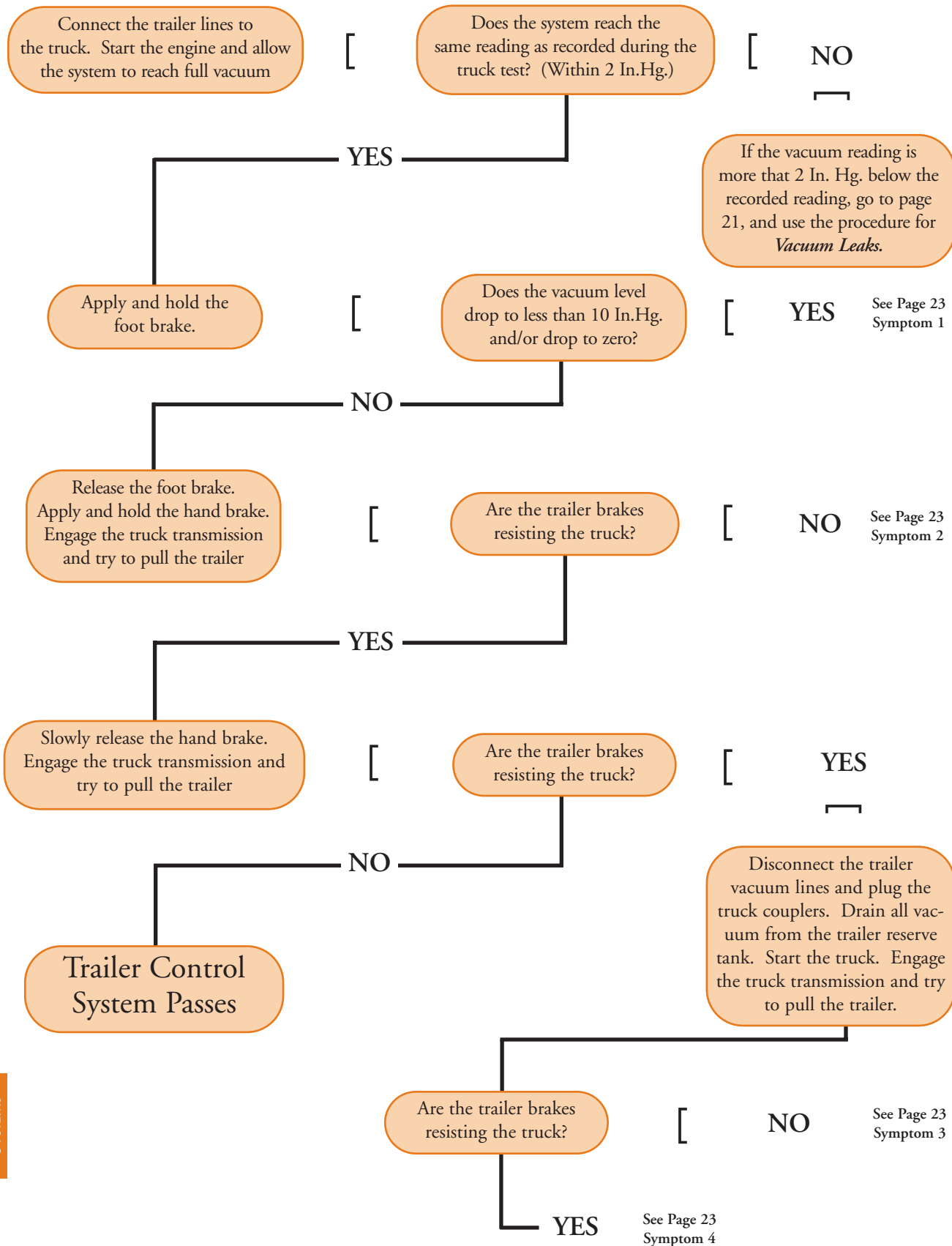

## Symptom 1:

The trailer system is losing vacuum when operated.

- 1) Disconnect the loop hose from the trailer relay valve to the booster master cylinder. Plug the end of the hose and the open port on the booster master cylinder. Apply and hold the foot brake. If vacuum drops as earlier, replace the relay valve. If vacuum does not drop, replace the trailer booster diaphragm or the trailer booster.

## Symptom 2:

The trailer system cannot produce hydraulic pressure

- 1) Check the trailer brake fluid reservoir. If low, fill the reservoir. If the booster is completely out of fluid or has been out of fluid in the past, rebleed the trailer brake system. Retry the failed portion of the test. If the test fails after this step, *go to step 2 below*.
- 2) Check brake shoe adjustment. If the axles are standard forget, refer to the Standard Forge axle adjustment procedure listed in the Troubleshooting Guide index. If the brakes needed adjustment, retry the failed portion of the test. If the test fails after this step, replace trailer booster.

## Symptom 3:

Failure of this portion of the test indicates a control problem which should have been identified earlier by the truck test or earlier steps in the trailer test. Rerun the truck test and the trailer test. Pay particular attention to the maximum obtainable vacuum reading. If the level is below 15 In.Hg. or drops below 15 In.Hg. after initial brake release, the booster may be consuming excessive amounts of vacuum during operation. This condition is most often caused by brake shoes out of adjustment. If the vacuum is slow to recover after brake release, make sure a vacuum pump is in the system and is in good working order. See the *Low Vacuum Chart* to diagnose this problem

## Symptom 4:

The Brakes are not releasing and there is no vacuum available to the brake booster.

- 1) Open the brake bleeder screw on the brake booster. Retry the failed portion of the test. If the test passes, replace the brake booster. If the test fails, the problem is in the trailer brake assemblies or possibly a crimped brake line. In either case, the truck and trailer control system and trailer booster are not at fault.

## LOW VACUUM CHART

If this chart has been referred to by other tests in the diagnostic procedure, the first step is to determine if the truck is equipped with a vacuum pump. All trucks after 1986 require a vacuum pump solely dedicated to the operation of the trailer brakes with the following exceptions: 1994 and later Chev/GMC 6.5 L diesels; Super Duty Ford Trucks prior to 1999 with 7.3L - 7.5L diesel engines.

The trucks listed as exceptions are equipped with factory vacuum pumps and are used only for accessory operations on the truck. This permits their use as a source for trailer brake vacuum.

If the system being diagnosed has operated properly in the past without a vacuum pump, the possible problem can be due to vacuum leaks or high altitude operation which reduces vacuum capability. If high altitude is present, vacuum capability is reduced 1 In.Hg. for every 1000 ft. of elevation. For example, if a vacuum pump produces 27 In.Hg. at sea level, the maximum gauge reading obtainable at 10,000 ft. elevation is 17 In.Hg. It may be necessary to reduce the vacuum levels requested in this chart by adjusting the values for altitude.

This chart assumes a vacuum pump as the source for trailer brake vacuum.

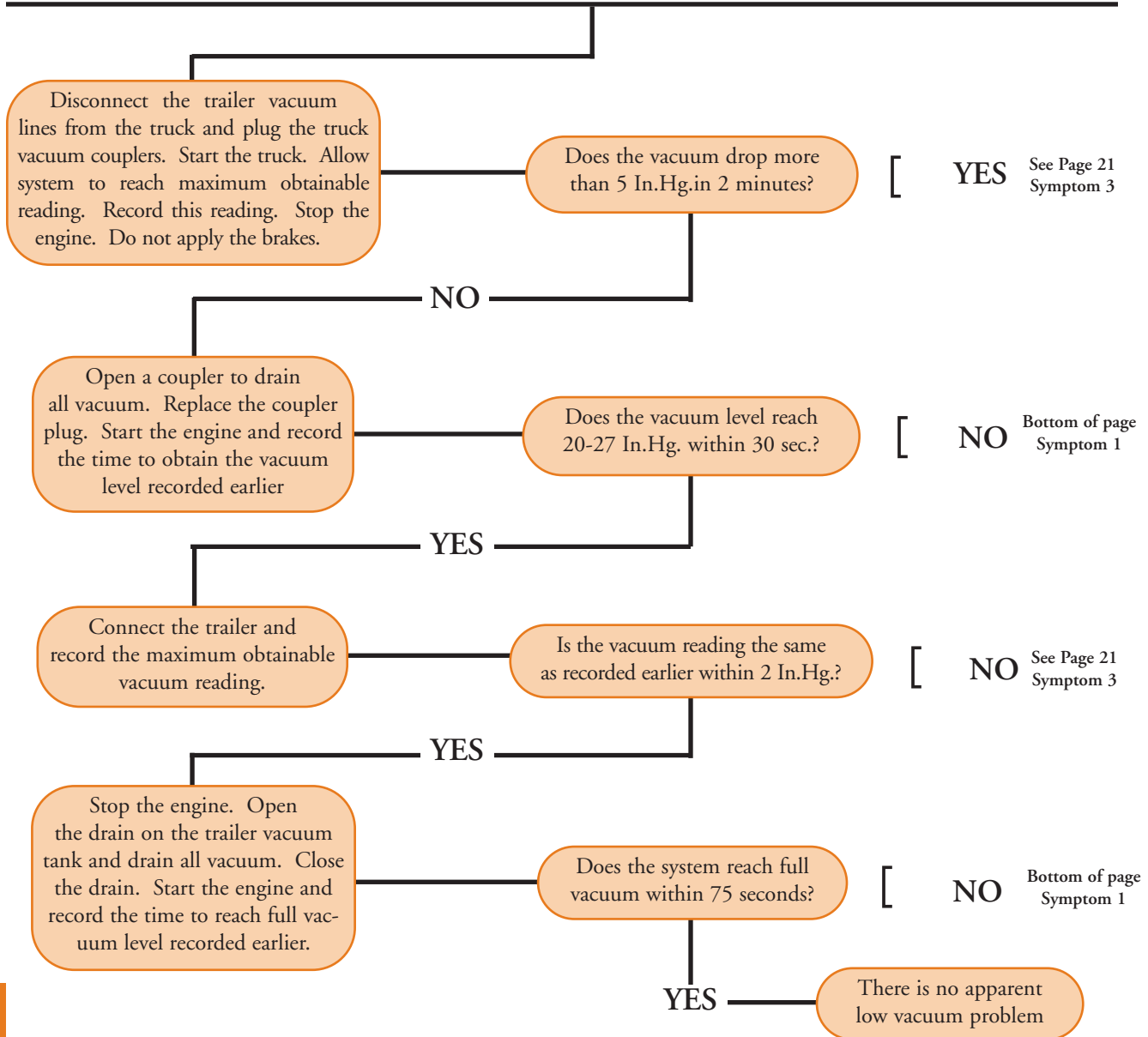

### SYMPTOM 1:

The vacuum pump appears to be weak or inoperative. Replace the Pump